

# 1541/1543

## Safety Valve



CONSOLIDATED Type 1541 and 1543 safety valves are designed for steam and other compressible fluids. They are most commonly used in pharmaceutical, dying and process plants.

1541 / 1543



**INLET SIZES** — 1/2" through 2-1/2" threaded

**OUTLET SIZES** — 3/4" through 2-1/2" threaded

**ORIFICE SIZES** — Six sizes: D through J

**PRESSURE RANGE** — 5 psig to 350 psig

**TEMPERATURE RANGE** — -20°F to 420°F

**MATERIALS** — Cast iron bonnet with brass base and trim is standard. Available with bronze bonnet. Stainless steel base and disc are also optional.

**CERTIFICATION** — ASME B&PVC Section I and VIII

**BLOWDOWN** — 4%

**BACK PRESSURE LIMIT** — 10% of Set Pressure

## Table of Contents

Scope of Design .....	1541/1543.1
Materials .....	1541/1543.3
Dimensions & Weights .....	1541/1543.4
Orifice Capacities .....	1541/1543.5

## Product Applications

### Options

**1543-3:** A duplicate of the 1543 valve, but supplied with a 304 stainless base and disc.

**1541-3:** A duplicate of 1541 valve, but supplied with a 304 stainless steel base and disc.

**Bronze Bonnet:** When cast iron bonnets are not permitted, a bronze bonnet option is available.

**Soft Seats:** A PTFE soft seat option is available for improved tightness. This option is only available for ASME Code Section VIII application.

**Low Pressures:** For low pressures, we supply a special low pressure design to ensure maximum flow capacities against atmospheric pressure.

**Spring:** When chrome alloy springs are not permitted, A 17-7PHSS is available.

### Connections

The 1541 valve is supplied with inlet sizes of 3/4" (19.1 mm) to 2-1/2" (63.5mm). The 1543 sizes are supplied with inlet connections of 1/2" (12.7mm) to 2" (50.8 mm). All inlet connections are male NPT with standard hex head on surfaces for easy wrenching.

**!** **CAUTION**

The discharged fluid may escape to the atmosphere through the bonnet vent and drain hole, so toxic or hazardous applications must be avoided.

**Valve Sizes / 1541**

Inlet Size Male NPT	Orifice Designation	Discharge Area		Outlet Size Female NPT
		in. <sup>2</sup>	cm <sup>2</sup>	
3/4"	D	.110	.710	3/4"
1"	E	.196	1.265	1"
1-1/4"	F	.307	1.981	1-1/4"
1-1/2"	G	.503	3.245	1-1/2"
2"	H	.785	5.065	2"
2-1/2"	J	1.287	8.304	2-1/2"

**Valve Sizes / 1543**

Inlet Size Male NPT	Orifice Designation	Discharge Area		Outlet Size Female NPT
		in. <sup>2</sup>	cm <sup>2</sup>	
1/2"	D	.110	.710	3/4"
3/4"	E	.196	1.265	1"
1"	F	.307	1.981	1-1/4"
1-1/4"	G	.503	3.245	1-1/2"
1-1/2"	H	.785	5.065	2"
2"	J	1.287	8.304	2-1/2"

**Pressure/Temperature Limits**

Valve Type	Set Pressure		Range Temperature				Back Pressure (max) psig
	Steam	Air	Minimum		Maximum		
	psig	psig	°F	°C	°F	°C	
1541	5-250	5-300	-20	-28	406	207	*
1541-BR	5-250	5-300	-20	-28	406	207	*
1541-3	5-300	5-350	-20	-28	420	215	*
1541-3-BR	5-300	5-350	-20	-28	420	215	*
1543	5-250	5-300	-20	-28	406	207	*
1543-BR	5-250	5-300	-20	-28	406	207	*
1543-3	5-300	5-350	-20	-28	420	215	*
1543-3-BR	5-300	5-350	-20	-28	420	215	*

\* Maximum backpressure not to exceed 10% of valve set pressure

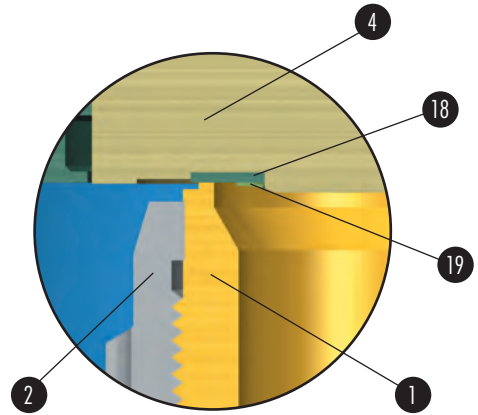
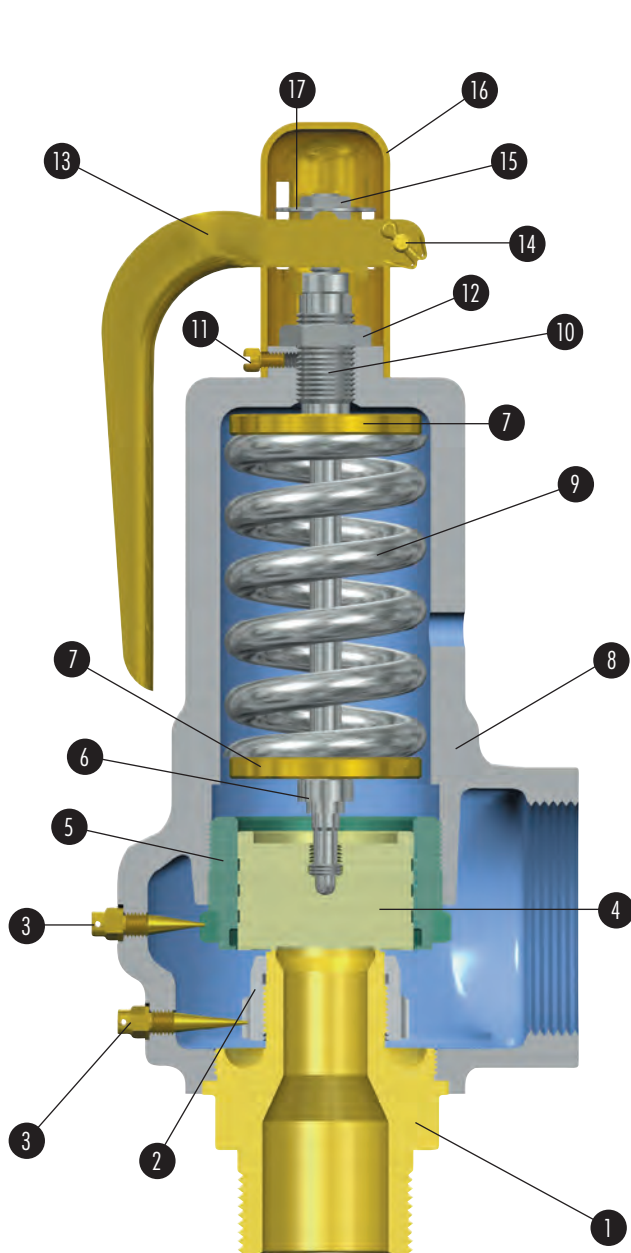

Soft Seat Design

Part	Material
1 Base	Brass (Stainless Steel on -3 design)
2 Lower Adjusting Ring	Brass
3 Adjusting Ring Pin	Brass
4 Disc	Brass (Stainless Steel on -3 design)
5 Upper Adjusting Ring	Brass
6 Spindle (D & E orifice)	Carbon Steel
6 Spindle Assembly (F,G,H, & J Orifice)	
Spindle	Carbon Steel
Collar	Stainless Steel
7 Spring Washer	Carbon Steel
8 Bonnet (Note 1)	Iron (Phosphate Coated)
9 Spring	Chrome Alloy (Aluminum Metalized)
10 Compression Screw	Brass
11 Cap Screw	Carbon Steel (Zinc Plated)
12 Compression Screw Nut	Carbon Steel
13 Lever	Brass
14 Lever Pin	Brass
15 Lifting Washer Nut	Carbon Steel
16 Cap	Brass
17 Lifting Washer	Carbon Steel (Zinc Plated)
18 Soft Seat	PTFE
19 Seat Retainer Ring	Stainless Steel

Notes:

1. Available with bronze bonnet.



\*Notes:

1. 1/4" (6.3mm) diameter drain hole located 60 degrees to the left when facing outlet.
2. 1/4" (6.3mm) diameter drain hole located 90 degrees to the left when facing outlet.
3. 1/4" (6.3mm) diameter drain hole located 105 degrees to the left when facing outlet.
4. 1/4" (6.3mm) diameter drain hole located 110 degrees to the left when facing outlet.

**1541 (USCS)**

Inlet Size	Type	A in	B in	C in	W in	Dismantling Height (in.)	Approximate Weight (lbs.)	Drain Hole Location
3/4"	1541D	6-11/16	2-5/16	1-7/16	2-1/4	8-1/4	2.0	Note 1
1"	1541E	7-1/16	2-9/16	1-9/16	2-1/2	8-5/8	3.0	Note 1
1-1/4"	1541F	8-15/16	2-15/16	1-15/16	3	10-1/2	4.5	Note 3
1-1/2"	1541G	9-3/4	3-1/8	2-1/4	3-1/2	11-5/8	7.7	Note 4
2"	1541H	11-5/16	3-11/16	2-5/8	4-3/8	13-1/8	10.5	Note 2
2-1/2"	1541J	13-1/16	4-1/4	3-3/8	5-1/8	15-1/8	17.7	Note 2

**1543 (USCS)**

Inlet Size	Type	A in	B in	C in	W in	Dismantling Height (in.)	Approximate Weight (lbs.)	Drain Hole Location
1/2"	1543D	6-5/8	2-1/4	1-7/16	2-1/4	8-1/4	2.0	Note 1
3/4"	1543E	6-15/16	2-7/16	1-9/16	2-1/2	8-1/2	2.7	Note 1
1"	1543F	8-3/4	2-3/4	1-15/16	3	10-1/4	4.2	Note 3
1-1/4"	1543G	9-11/16	3-1/16	2-1/4	3-1/2	11-1/2	7.5	Note 4
1-1/2"	1543H	11-3/16	3-9/16	2-5/8	4-3/8	13-1/4	10.0	Note 2
2"	1543J	12-13/16	4	3-3/8	5-1/8	14-7/8	16.7	Note 2

**1541 (metric units)**

Inlet Size	Type	A mm	B mm	C mm	W mm	Dismantling Height (mm)	Approximate Weight (kg)	Drain Hole Location
3/4"	1541D	169.8	58.7	36.5	57.2	209.6	0.9	Note 1
1"	1541E	179.4	65.1	39.7	63.5	219.1	1.4	Note 1
1-1/4"	1541F	227.0	74.6	49.2	76.2	266.7	2.1	Note 3
1-1/2"	1541G	247.7	79.4	57.2	88.9	295.3	3.5	Note 4
2"	1541H	287.3	93.6	66.7	111.1	333.4	4.8	Note 2
2-1/2"	1541J	331.8	107.9	85.7	130.2	384.2	8.1	Note 2

**1543 (metric units)**

Inlet Size	Type	A mm	B mm	C mm	W mm	Dismantling Height (mm)	Approximate Weight (kg)	Drain Hole Location
1/2"	1543D	168.3	57.2	36.5	57.2	209.6	0.9	Note 1
3/4"	1543E	176.2	61.9	39.7	63.5	215.9	1.2	Note 1
1"	1543F	222.3	69.9	49.2	76.2	260.4	1.9	Note 3
1-1/4"	1543G	246.0	77.8	57.2	88.9	292.1	3.4	Note 4
1-1/2"	1543H	284.1	90.5	66.7	111.1	336.6	4.5	Note 2
2"	1543J	325.4	101.6	85.7	130.2	377.8	7.6	Note 2

**! CAUTION**

Do not plug drain holes. The discharged fluid may escape to the atmosphere through the bonnet vent and drain connections, so toxic or hazardous applications must be avoided.

**ASME, B & PVC, Section I rating - 2001 Edition**  
pounds per hour saturated steam at 3% overpressure or 2 psig,  
whichever is greater, 90% of actual capacity

W=51.5KAP  
K=.878  
A=flow area in sq. in.  
P=(1.03 x set pressure) + 14.7  
or P=(2 psig + set pressure) + 14.7

Not for use on superheated steam.  
Review pressure/temperature limits  
on page 1541/1543.2.

Orifice Designation & Area - Square Inches						
Orifice Designation Orifice Area Sq. In. Set Pressure (psig)	D 0.110	E 0.196	F 0.307	G 0.503	H 0.785	J 1.287
15	157	280	440	720	1125	1844
20	182	325	509	834	1302	2135
25	207	369	578	948	1480	2426
30	232	413	648	1062	1657	2717
35	257	458	717	1175	1835	3008
40	282	502	787	1289	2012	3299
45	306	546	856	1403	2190	3590
50	331	591	925	1517	2367	3881
55	356	635	995	1630	2545	4172
60	381	679	1064	1744	2722	4463
65	406	724	1134	1858	2899	4754
70	431	769	1204	1974	3080	5051
75	457	814	1276	2091	3263	5350
80	482	860	1347	2208	3446	5650
85	508	906	1419	2325	3629	5950
90	534	951	1490	2442	3812	6250
95	559	997	1562	2559	3995	6549
100	585	1043	1633	2676	4177	6849
105	611	1088	1705	2794	4360	7149
110	636	1134	1776	2911	4543	7448
115	662	1180	1848	3028	4726	7748
120	687	1225	1919	3145	4909	8048
125	713	1271	1991	3262	5091	8347
130	739	1316	2062	3379	5274	8647
135	764	1362	2134	3496	5457	8947
140	790	1408	2205	3614	5640	9247
145	815	1453	2277	3731	5823	9546
150	841	1499	2348	3848	6005	9846
155	867	1545	2420	3965	6188	10146
160	892	1590	2491	4082	6371	10445
165	918	1636	2563	4199	6554	10745
170	944	1682	2634	4316	6737	11045
175	969	1727	2706	4433	6919	11344
180	995	1773	2777	4551	7102	11644
185	1020	1819	2849	4668	7285	11944
190	1046	1864	2920	4785	7468	12244
195	1072	1910	2992	4902	7651	12543
200	1097	1955	3063	5019	7833	12843
205	1123	2001	3135	5136	8016	13143
210	1148	2047	3206	5253	8199	13442
215	1174	2092	3278	5371	8382	13742
220	1200	2138	3349	5488	8565	14042
225	1225	2184	3421	5605	8747	14341
230	1251	2229	3492	5722	8930	14641
235	1277	2275	3564	5839	9113	14941
240	1302	2321	3635	5956	9296	15241
245	1328	2366	3707	6073	9479	15540
250	1353	2412	3778	6190	9661	15840
255	1379	2458	3850	6308	9844	16140
260	1405	2503	3921	6425	10027	16439
265	1430	2549	3993	6542	10210	16739
270	1456	2594	4064	6659	10393	17039
275	1481	2640	4136	6776	10575	17338
280	1507	2686	4207	6893	10758	17638
285	1533	2731	4279	7010	10941	17938
290	1558	2777	4350	7128	11124	18238
295	1584	2823	4421	7245	11307	18537
300	1610	2868	4493	7362	11489	18837

**ASME, B & PVC, Section VIII rating - 2001 Edition**  
pounds per hour saturated steam at 10% overpressure or 3 psig,  
whichever is greater, 90% of actual capacity

W=51.5KAP  
K=.878  
A=flow area in sq. in.  
P=(1.10 x set pressure) + 14.7  
or P=(3 psig + set pressure) + 14.7

Not for use on superheated steam.  
Review pressure/temperature limits  
on page 1541/1543.2.

Orifice Designation & Area - Square Inches						
Orifice Designation Orifice Area Sq. In. Set Pressure (psig)	D 0.110	E 0.196	F 0.307	G 0.503	H 0.785	J 1.287
15	162	289	453	743	1160	1902
20	187	334	523	857	1338	2193
25	212	378	592	971	1515	2484
30	237	422	662	1084	1693	2775
35	264	471	738	1209	1888	3095
40	291	520	814	1335	2083	3416
45	319	568	891	1460	2278	3736
50	346	617	967	1585	2474	4056
55	374	666	1043	1710	2669	4376
60	401	715	1120	1835	2864	4696
65	428	763	1196	1960	3059	5016
70	456	812	1272	2085	3254	5336
75	483	861	1349	2210	3450	5656
80	510	910	1425	2335	3645	5976
85	538	958	1501	2460	3840	6296
90	565	1007	1578	2586	4035	6616
95	592	1056	1654	2711	4231	6936
100	620	1105	1731	2836	4426	7256
105	647	1153	1807	2961	4621	7576
110	674	1202	1883	3086	4816	7896
115	702	1251	1960	3211	5011	8216
120	729	1300	2036	3336	5207	8536
125	757	1348	2112	3461	5402	8856
130	784	1397	2189	3586	5597	9176
135	811	1446	2265	3711	5792	9496
140	839	1495	2341	3836	5988	9816
145	866	1543	2418	3962	6183	10136
150	893	1592	2494	4087	6378	10456
155	921	1641	2570	4212	6573	10776
160	948	1690	2647	4337	6768	11096
165	975	1738	2723	4462	6964	11416
170	1003	1787	2799	4587	7159	11736
175	1030	1836	2876	4712	7354	12056
180	1057	1885	2952	4837	7549	12376
185	1085	1933	3028	4962	7745	12696
190	1112	1982	3105	5087	7940	13016
195	1140	2031	3181	5212	8135	13336
200	1167	2080	3258	5338	8330	13656
205	1194	2128	3334	5463	8525	13976
210	1222	2177	3410	5588	8721	14296
215	1249	2226	3487	5713	8916	14616
220	1276	2275	3563	5838	9111	14936
225	1304	2323	3639	5963	9306	15256
230	1331	2372	3716	6088	9502	15576
235	1358	2421	3792	6213	9697	15896
240	1386	2469	3868	6338	9892	16216
245	1413	2518	3945	6463	10087	16536
250	1440	2567	4021	6588	10283	16856
255	1468	2616	4097	6714	10478	17176
260	1495	2664	4174	6839	10673	17496
265	1522	2713	4250	6964	10868	17816
270	1550	2762	4326	7089	11063	18136
275	1577	2811	4403	7214	11259	18456
280	1605	2859	4479	7339	11454	18776
285	1632	2908	4555	7464	11649	19096
290	1659	2957	4632	7589	11844	19416
295	1687	3006	4708	7714	12040	19736
300	1714	3054	4784	7839	12235	20056

## ASME, B & PVC, Section VIII rating - 2001 Edition

### Standard Cubic Feet per minute of Air (60F) at 10% overpressure or 3 psig, whichever is greater

$W=18.331 \cdot A \cdot P \cdot K$   
 $K=.878$   
 A= flow area in sq. in.  
 $P=(1.10 \cdot \text{set pressure}) + 14.7$   
 or  $P=(3 + \text{set pressure}) + 14.7$

**Orifice Designation & Area - Square Inches**

Orifice Designation Orifice Area Sq. In. Set Pressure (psig)	D 0.110	E 0.196	F 0.307	G 0.503	H 0.785	J 1.287
15	58	103	161	265	413	677
20	67	119	186	305	476	780
25	76	135	211	345	539	884
30	84	150	236	386	602	987
35	94	168	263	430	672	1101
40	104	185	290	475	741	1215
45	114	202	317	519	811	1329
50	123	220	344	564	880	1443
55	133	237	371	608	950	1557
60	143	254	399	653	1019	1671
65	153	272	426	697	1088	1785
70	162	289	453	742	1158	1898
75	172	306	480	786	1227	2012
80	182	324	507	831	1297	2126
85	191	341	534	875	1366	2240
90	201	358	561	920	1436	2354
95	211	376	589	964	1505	2468
100	221	393	616	1009	1575	2582
105	230	410	643	1053	1644	2695
110	240	428	670	1098	1713	2809
115	250	445	697	1142	1783	2923
120	260	463	724	1187	1852	3037
125	269	480	752	1231	1922	3151
130	279	497	779	1276	1991	3265
135	289	515	806	1320	2061	3379
140	298	532	833	1365	2130	3492
145	308	549	860	1409	2200	3606
150	318	567	887	1454	2269	3720
155	328	584	915	1498	2339	3834
160	337	601	942	1543	2408	3948
165	347	619	969	1587	2477	4062
170	357	636	996	1632	2547	4176
175	367	653	1023	1676	2616	4289
180	376	671	1050	1721	2686	4403
185	386	688	1078	1765	2755	4517
190	396	705	1105	1810	2825	4631
195	406	723	1132	1854	2894	4745
200	415	740	1159	1899	2964	4859

**Orifice Designation & Area - Square Inches**

Orifice Designation Orifice Area Sq. In. Set Pressure (psig)	D 0.110	E 0.196	F 0.307	G 0.503	H 0.785	J 1.287
205	425	757	1186	1943	3033	4973
210	435	775	1213	1988	3102	5086
215	444	792	1240	2032	3172	5200
220	454	809	1268	2077	3241	5314
225	464	827	1295	2121	3311	5428
230	474	844	1322	2166	3380	5542
235	483	861	1349	2210	3450	5656
240	493	879	1376	2255	3519	5770
245	503	896	1403	2299	3589	5884
250	513	913	1431	2344	3658	5997
255	522	931	1458	2388	3728	6111
260	532	948	1485	2433	3797	6225
265	542	965	1512	2477	3866	6339
270	552	983	1539	2522	3936	6453
275	561	1000	1566	2566	4005	6567
280	571	1017	1594	2611	4075	6681
285	581	1035	1621	2655	4144	6794
290	590	1052	1648	2700	4214	6908
295	600	1069	1675	2744	4283	7022
300	610	1087	1702	2789	4353	7136
305	620	1104	1729	2833	4422	7250
310	629	1121	1757	2878	4491	7364
315	639	1139	1784	2922	4561	7478
320	649	1156	1811	2967	4630	7591
325	659	1173	1838	3011	4700	7705
330	668	1191	1865	3056	4769	7819
335	678	1208	1892	3100	4839	7933
340	688	1225	1919	3145	4908	8047
345	697	1243	1947	3189	4978	8161
350	707	1260	1974	3234	5047	8275

## Capacities For Set Pressure Less Than 15 psig. ASME Code Stamping not allowed.

### Capacities (<15 Psig) Steam

lb/hr Steam, 3 psi Overpressure Orifice Designation & Discharge Area - Sq. Inches						
Orifice Designation Orifice Area Sq. In. Set Pressure (psig)	D 0.110	E 0.196	F 0.307	G 0.503	H 0.785	J 1.287
5	110	195	306	502	783	1283
6	116	207	324	530	827	1356
7	122	217	340	557	869	1425
8	127	227	355	582	908	1489
9	133	236	370	606	946	1550
10	138	245	384	629	982	1610
11	143	254	398	652	1017	1668
12	148	263	412	675	1053	1726
13	152	272	426	697	1088	1784
14	157	281	439	720	1124	1842

### Capacities (<15 Psig) Air

SCFM Air, 3 psi Overpressure Orifice Designation & Discharge Area - Sq. Inches						
Orifice Designation Orifice Area Sq. In. Set Pressure (psig)	D 0.110	E 0.196	F 0.307	G 0.503	H 0.785	J 1.287
5	39	69	108	178	277	455
6	41	73	115	188	294	481
7	43	77	121	198	309	506
8	45	81	126	207	323	530
9	47	84	132	216	337	552
10	49	87	137	224	350	573
11	51	91	142	232	362	594
12	53	94	147	240	375	615
13	54	97	152	248	388	636
14	56	100	157	257	400	656