

CONSOLIDATED®

INSTRUCTIONS FOR INSTALLATION, OPERATION AND REPAIR

2478 BRONZE RELIEF VALVES



DRESSER VALVE AND CONTROLS DIVISION
Industrial Valve North American Operations
Alexandria, Louisiana

SAFETY NOTICE

PROPER SERVICE AND REPAIR IS IMPORTANT TO THE SAFE, RELIABLE OPERATION OF ALL VALVE PRODUCTS. THE SERVICE PROCEDURES RECOMMENDED BY DRESSER INDUSTRIAL VALVE OPERATION (DIVO) AND DESCRIBED IN THIS MAINTENANCE AND SERVICE MANUAL ARE EFFECTIVE METHODS OF PERFORMING THE REQUIRED MAINTENANCE OPERATIONS. SOME OF THESE SERVICE OPERATIONS REQUIRE THE USE OF TOOLS SPECIFICALLY DESIGNED FOR THE PURPOSE. THESE SPECIAL TOOLS SHOULD BE USED WHEN AND AS RECOMMENDED.

IT IS IMPORTANT TO NOTE THAT THIS SERVICE MANUAL CONTAINS VARIOUS WARNINGS AND CAUTIONS WHICH SHOULD BE CAREFULLY READ IN ORDER TO MINIMIZE THE RISK OF PERSONAL INJURY OR THE POSSIBILITY THAT IMPROPER SERVICE METHODS WILL BE FOLLOWED WHICH MAY DAMAGE THE VALVE OR RENDER IT UNSAFE. IT IS ALSO IMPORTANT TO UNDERSTAND THAT THESE WARNINGS AND CAUTIONS ARE NOT EXHAUSTIVE. DIVO COULD NOT POSSIBLY KNOW, EVALUATE, AND ADVISE THE CUSTOMER OR UTILITY OF ALL CONCEIVABLE WAYS IN WHICH SERVICE MIGHT BE DONE, OR OF THE POSSIBLE HAZARDOUS CONSEQUENCES OF EACH WAY. CONSEQUENTLY, DIVO HAS NOT UNDERTAKEN ANY SUCH BROAD EVALUATION. ACCORDINGLY, ANYONE WHO USES A SERVICE PROCEDURE OR TOOL WHICH IS NOT RECOMMENDED BY DIVO MUST SATISFY HIMSELF THOROUGHLY THAT NEITHER HIS OR OTHER PERSONNEL'S SAFETY NOR VALVE SAFETY AND PROPER OPERATION WILL BE JEOPARDIZED BY THE SERVICE METHOD HE SELECTS. CONTACT DIVO IF THERE IS ANY QUESTION ON THE METHOD.

THE TESTING, INSTALLATION, AND REMOVAL OF VALVE AND VALVE PRODUCTS MAY INVOLVE THE USE OF FLUIDS AT EXTREMELY HIGH PRESSURE AND TEMPERATURE AND/OR ARE CORROSIVE OR EROSIVE. CONSEQUENTLY, EVERY PRECAUTION SHOULD BE TAKEN TO PREVENT INJURY TO PERSONNEL DURING THE PERFORMANCE OF ANY TEST, INSTALLATION OR REMOVAL SUCH AS, BUT NOT LIMITED TO, EAR DRUM PROTECTION, EYE PROTECTION, AND PROTECTIVE CLOTHING SUCH AS GLOVES, ETC., IN AND AROUND THE TESTING, INSTALLATION, OR REMOVAL AREA. DUE TO THE VARIOUS CIRCUMSTANCES AND CONDITIONS IN WHICH THESE OPERATIONS MAY BE PERFORMED ON OUR PRODUCTS, OR THE POSSIBLE HAZARDOUS CONSEQUENCES OF EACH WAY, DIVO COULD NOT POSSIBLY EVALUATE ALL CONDITIONS THAT COULD INJURE PERSONNEL OR EQUIPMENT, BUT DOES OFFER THESE SAFETY PRECAUTIONS AS AN ASSISTANCE ONLY.

SAFETY PRECAUTIONS

1. DO NOT STAND IN FRONT OF THE DISCHARGE SIDE OF A PRESSURE RELIEF VALVE WHEN TESTING OR OPERATING.
2. HEARING PROTECTION SHOULD BE USED WHEN TESTING OR OPERATING VALVE.
3. EXERCISE CAUTION WHEN EXAMINING A PRESSURE RELIEF VALVE FOR VISIBLE LEAKAGE.
4. NEVER INSTALL A PRESSURE RELIEF VALVE IN A HORIZONTAL POSITION. PRESSURE RELIEF VALVE INTERNALS ARE DESIGNED TO MOVE VERTICALLY, WHEN INSTALLED HORIZONTALLY, MISALIGNMENT AND GALLING OR HANG-UP MAY PREVENT THE VALVE FROM OPENING OR CLOSING PROPERLY.
5. PRESSURE RELIEF VALVES SHOULD BE MOUNTED TO PROVIDE ADEQUATE ACCESS, 360° AROUND THE VALVE PLUS OVERHEAD TO PERMIT REMOVAL FOR TESTING AND MAINTENANCE.
6. WHEN REMOVING THE PRESSURE RELIEF VALVE DURING DISASSEMBLY, STAND CLEAR AND/OR WEAR PROTECTIVE CLOTHING TO PREVENT EXPOSURE TO SPLATTER OF ANY CORROSIVE PROCESS MEDIUM WHICH MAY HAVE BEEN TRAPPED INSIDE. ENSURE VALVE IS ISOLATED FROM SYSTEM PRESSURE BEFORE VALVE IS REMOVED.
7. WHEN A VALVE IS EQUIPPED WITH A LIFTING LEVER, THE LEVER SHOULD BE POSITIONED TO AVOID ACCIDENTAL CONTACT BY OTHER EQUIPMENT OR PERSONNEL, WHICH MIGHT CAUSE VALVE TO LIFT ACCIDENTALLY.

TABLE OF CONTENTS

Section	Description	Page
	Safety Notice	1
	Safety Precautions	1
	Table of Contents	2
	Terminology for Relief Valves	3
I.	Introduction	3
II.	Descriptions, Applications and Product Features	4
III.	Operating Principle	5
IV.	Handling, Storage, Preinstallation	5
V.	Installation	5
VI.	Valve Disassembly for Repair	5
VII.	Repair and Lapping	5
VIII.	Reassembly	6
IX.	Testing	7
X.	Trouble Shooting	7
XI.	Replacement Parts, Tools and Supplies	7

TERMINOLOGY FOR RELIEF VALVES

1. **Back Pressure**
Back pressure is the static pressure existing at the outlet of a relief device due to pressure in the discharge system.
2. **Blowdown**
Blowdown is the difference between actual opening pressure of a relief valve and actual reseating pressure expressed as a percentage of set pressure or in pressure units.
3. **Bore Area**
Bore area is the minimum cross-sectional area of the nozzle.
4. **Bore Diameter**
Bore diameter is the minimum diameter of the nozzle.
5. **Closing Pressure**
Closing pressure is the value of decreasing inlet static pressure at which the valve disc reestablishes contact with the seat or at which lift becomes zero.
6. **Disc**
A disc is the pressure containing moveable element of a pressure relief valve which effects closure.
7. **Inlet Size**
Inlet size is the nominal pipe size of the inlet of a pressure relief valve unless otherwise designated.
8. **Lift**
Lift is the actual travel of the disc away from closed position when a valve is relieving.
9. **Lifting Device**
A lifting device is a device for manually opening a safety device by the application of external force to lessen the spring loading which holds the valve closed.
10. **Nozzle**
A nozzle is the pressure containing element which constitutes the inlet flow passage and includes the fixed portion of the seat closure.
11. **Outlet Size**
Outlet size is the nominal pipe size of the outlet of a relief valve, unless otherwise designated.

12. **Overpressure**
Overpressure is a pressure increase over the set pressure of a relief valve, usually expressed as a percentage of set pressure.
13. **Set Pressure**
Set pressure is the value of increasing inlet static pressure at which the disc moves in the opening direction.
14. **Seat**
A seat is the pressure containing contact between the fixed and moving portions of the pressure containing elements of a valve.
15. **Seat Diameter**
Seat diameter is the smallest diameter of contact between the fixed and moving portions of the pressure containing elements of a valve.

I. INTRODUCTION

A relief valve is a key safety device that protects against catastrophic pressure vessel failure. However, if it is not properly installed, maintained, operated and repaired, the pressure vessel is like a potential bomb. For example:

A 30-gallon hot water tank at 90 psig has 3,138,400 ft-lb of energy to flash its water into steam at 330°F if liberated by rupture. Energy of a pound of three common explosives is:

Black powder	960 ft-lb
Smokeless powder	1260 ft-lb
Nitroglycerin	2,000,000 ft-lb

On this basis, the 30-gallon tank is equivalent to about 1½ lbs. of nitroglycen. Catastrophes, of course, are not the only loss exposure from improper relief-valve operation. Overpressure can rupture tubing and blow out packing. Improperly maintained relief valves can also fail safe—in the sense that they may relieve at too low a pressure or may leak, so the equipment never reaches the desired pressure or full efficiency. Hence, proper installation, maintenance and repair is as important as the buying of a reliable valve. This manual provides instructions for installation, maintenance and repair of Consolidated® Bronze Relief Valves.

II. PARTS AND MATERIAL

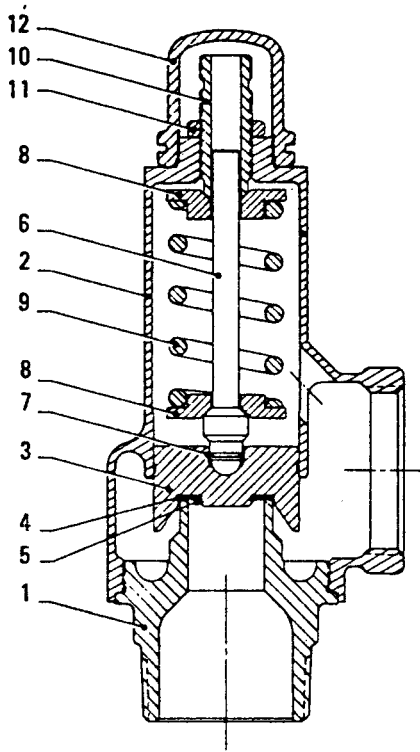

TYPE 2478

STANDARD SOFT SEAT DESIGN

Ref. No.	Nomenclature	Material
1	Base	Brass
2	Bonnet	Bronze
3	Disc	Brass
4	Soft Seat	See Below**
5	Seat Retainer Ring	Stainless Steel
6	Spindle	Bronze
7	Spindle Retainer Ring	Stainless Steel
8	Spring Washer	Brass
9	Spring	Carbon Steel Stainless Steel*
10	Compression Screw	Brass
11	Compression Screw Locknut	Brass
12	Screwed Cap	Thermoplastice

*Stainless steel spring is specified for temperatures below -20°F and cryogenic applications.

Material	**Soft Seat Selection	
	Temperature Range	Pressure Range
	$^{\circ}\text{F}$	PSI
Viton A	-10 to 400	0 to 300
Silicone Buna N Ethylene-Propylene	-23.3 to 204.4	(0 to 20.7)
Teflon	-59.4 to 204.4	151 to 300
	-325 to 406	(10.4 to 20.7)
	-59.4 to 207.8	

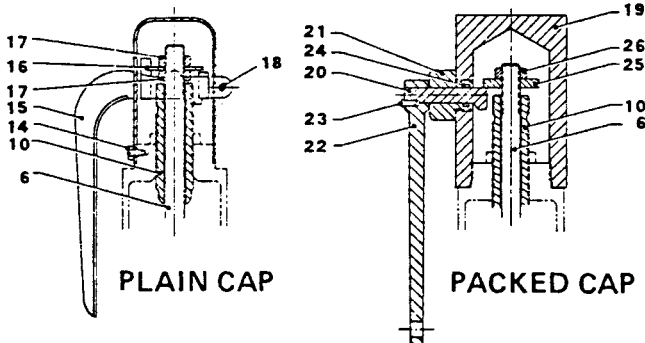

PLAIN CAP

PACKED CAP

Ref No.	Nomenclature	Material
13	Plain Cap	Brass
14	Cap Screw	Carbon Steel
15	Lifting Lever	Brass
16	Lifting Washer	Carbon Steel
17	Lifting Washer Nut	Carbon Steel
18	Lever Pin	Brass
19	Packed Cap	Brass
20	Cam Shaft	Stainless Steel
21	Bushing	Stainless Steel
22	Lever	Iron
23	Drive Screw	Stainless Steel
24	"O" Ring	Buna N (70)
25	Release Nut	Stainless Steel
26	Release Locknut	Carbon Steel

Ordering Information

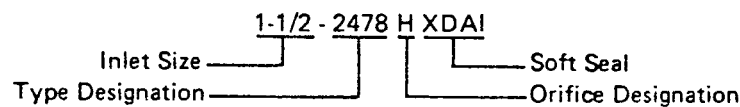

NOTE: To order metal seat, omit XDAI. Also specify cap required.

III. OPERATING PRINCIPLE

During system operating conditions, the spring force applied due to compression screw is higher than the upward acting pressure force on the disc. As a result, the valve is in the closed position. When system pressure reaches the opening pressure of the valve, the upward acting pressure force equals the downward acting spring force, hence valve begins to open. If system pressure increases more than the opening pressure, the valve opens proportionately. There is no pop type action on the liquid valve due to an absence of expansion characteristics in liquid (incompressible fluid). The valve lift will depend upon the degree of overpressure. During the lifting action, the disc is guided in precisely machine bonnet guiding surface. The valve closes, once system pressure reaches closing pressure of the valve.

IV. HANDLING, STORAGE AND PREINSTALLATION

1. The valves should be stored in a dry environment to protect them from the weather.
2. The valves should never be subjected to sharp impact. This would be most likely to occur by bumping or dropping during loading or unloading from a truck or while moving with a power conveyor, such as a fork lift truck.
3. Meticulous care should be exercised to prevent dirt and other foreign materials from entering the inlet and outlet ports during storage as well as in installation.

V. INSTALLATION

Valve Type 2478 is provided with a male NPT inlet connection and a standard hexagon surface for easy wrench installation. Exhaust outlets are female NPT connections suitable for standard size pipe fittings. The 2478 relief valve must be connected in an upright vertical position on equal size fittings. Furthermore in no case should the discharge pipe connected to the valve be of a smaller size than the valve outlet. No stop valve or other obstruction should be placed between the equipment and the relief valve.

Thoroughly clean the inlet of the valve before installation and be sure that no pipe thread compound gets into the bore of the valve during installation.

During installation do not use excessive wrenching force that may distort the hex on the valve base. The valve must not be tightened by means of a pipe screwed into the outlet. The valve at all times should be free from the discharge piping. The riser pipe should be large enough to accommodate the full capacity of the valve without causing a back pressure build up on the valve.

VI. VALVE DISASSEMBLY FOR REPAIR

1. Remove Screwed Cap, Packed Cap-Lever or Plain Cap-Lever assembly.
2. Remove Lifting Washer and Lifting Washer-Locknuts in valves with cap-lever assembly.
3. Release Compression Screw Locknut and release spring compression by turning Compression Screw counter-clockwise.
4. With valve Base held in vise loosen Bonnet to Base connection (use strap wrench, do not use pipe wrench as this may crush the bonnet).
5. Remove Bonnet, Disc, Spindle, Spring and Spring Washer assembly from Base, holding Spindle to be sure Disc does not drop.
6. Remove Disc, Spindle, Spring and Spring Washers from Bonnet.
7. Remove Disc by pulling the Spindle out of Disc pocket.
8. If soft Seat is damaged as shown by nicks, cuts and dents, remove Retainer Ring by a sharp tool. Subsequently, remove soft Seat using the same tool. These two parts must not be used again.

VII. REPAIR AND LAPPING

The valve repair operation will depend upon the damage. In some cases, it is easier to replace the part. In a number of cases, only nozzle and disc need to be repaired. This can be done in the following manner:

- a. Soft seated disc:
If the disc is damaged as shown by nicks, cuts, dents on the soft seat, it is to be replaced by using any sharp tool to pull out the retaining ring, then soft seat. See Reassembly Procedure for installing new soft seat.

- b. **Metallic Seating Surface:**
Reconditioning of the metallic seating surface of the Disc and Base is accomplished by lapping with a flat cast iron ring lap coated with Grade No. 1000 KWIK-AK-SHUN Silicon-Carbide compound, or equivalent.

Lapping a flat seat is extremely simple. No special skill is required and the technique is readily apparent after a few minutes of actual lapping.

The following precautions and hints will enable anyone to do a "Professional" job of lapping seats.

1. Keep the work clean.
2. Always use a fresh lap. If signs of wearing (out of flatness) are evident, recondition the lap.
3. Apply a very thin layer of compound to the lap. This will prevent rounding off the edges of the seat.
4. Keep the lap squarely on the flat surface and avoid any tendency to rock the lap which will cause rounding of the seat.
5. When lapping the Base keep a firm grip on the lap or part to prevent the possibility of dropping it and damaging the seat.
6. Lap, using a reciprocating motion in all directions, at the same time applying uniform pressure and rotating the lap or the part slowly. If reconditioning necessitates removing more than .010, replace the base.
7. When lapping the Disc Seat, the Disc should be held stationary and the lap moved as above. If reconditioning necessitates removing more than .010, replace the disc.
8. Replace the compound frequently after wiping off the old compound, and apply more pressure to speed the cutting action of the compound.
9. To check the seating surfaces, remove all compound from both the seat and the lap. Then shine up the seat with the same lap using the lapping motion described above. Low sections on the seating surface will show up as a shadow in contrast to the shiny portion. If shadows are present, further lapping is necessary, and only laps known to be flat should now be used. Only a few minutes will be required to remove the shadows.
10. When the lapping is completed, any lines appearing as cross scratches can be removed by rotating the lap, which has been wiped clean of compound,

on the seat about its own axis.

11. The seat should now be thoroughly cleaned with kerosene, light oil, or carbon tetrachloride, using a lint-free cloth or tissue paper.

VIII. REASSEMBLY

1. Clean seats and all parts
2. If valve disc is soft seated, use following procedure to perform proper assembly:
 - a. Clean disc and place it on a level metallic plate as shown in Figure 1. Disc surface having the spindle pocket will lie on the metal plate.
 - b. Pick-up proper soft seat; clean this with lint free cloth. Inspect it for nicks, cuts, dents (defective soft seat should be rejected). Place soft seat onto the disc as shown in Figure 1.
 - c. Pick-up proper retaining ring and tool assembly (see Table 1). Place retaining ring on the disc post (see Figure 1). Subsequently put the retaining ring tool assembly in a mechanical press (not shown in Figure 1). By applying slight force, position retaining ring over the disc post. Inspect the ring to ensure its proper positioning. Subsequently, press the ring hard enough to move it down to provide tight retaining of the soft seat. A properly assembled soft seat will be somewhat compressed by the retaining ring.
3. Install retainer ring in spindle. Subsequently force spindle in disc pocket.
4. Insert disc, spindle, spring and spring washer assembly to bonnet.
5. Holding bonnet and spindle (so that disc will not drop), install bonnet assembly to the base. Tighten bonnet on base using torque values: D: 50 ft-lb, E: 60 ft-lb, G: 75 ft-lb, H: 90 ft-lb, J: 100 ft-lb.
6. Assemble compression screw and provide spring compression by two turns of compression screw. The desired spring compression must be established by testing valve.

TABLE 1
2478 BRONZE VALVE SOFT SEAT ASSEMBLY TOOLS

Valve Type	Retaining Ring	Assembly Tool No.
2478D	2091155	7530160
2478E	2091156	7530141
2478F	2091157	7530142
2478G	2091158	7530143
2478H	2091160	7530162
2478J	2091162	7530147

IX. TESTING

To change opening pressure of the valve, loosen the locknut. Turn the compression screw clockwise to increase pressure or counter-clockwise to decrease pressure. The opening pressure of the valve is indicated by the first continuous discharge of the liquid through outlet. Before opening, in a number of cases, liquid will discharge one drop at a time. This is not to be confused with valve opening pressure. This should happen beyond the leak tightness pressure of the valve and before its opening pressure.

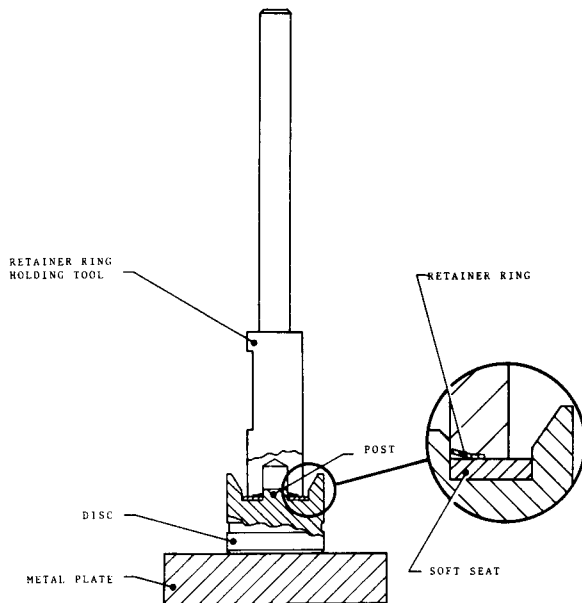

FIGURE 1
2478 SOFT SEAT ASSEMBLY

X. TROUBLE SHOOTING

Certain troubles may develop through use or damage to working parts. The most common are leakage, chattering, hang-up, and set pressure variation.

Leakage is the constant escape of liquid at normal operating pressure below the leak tightness pressure of the valve. It is caused by either damage to the seating

surfaces or to foreign matter being trapped. If pressure testing or manual lifting, wide open does not give relief, the valve should be repaired at the first opportunity to prevent further damage. Other causes of leakage are bent spindle that causes hang-up and improper installation of discharge piping so as to introduce undue strain upon the valve.

Chattering is a hammering action of a vibratory nature of the disc on the nozzle seat and must be stopped immediately to protect the seating surface. Chattering is caused by excessive back pressure from undersize discharge piping, insufficient flow compared to the rated flow and an undersize or closed vent hole in the bonnet outlet.

Hang-up occurs upon closing and is defined as leakage from the valve failing to shut-off tightly. Mechanical interference is the primary cause. Disc and disc guiding area in the bonnet should be examined.

Set pressure variation may be caused by spring relaxation, damage to the seats from foreign matter, from chatter or difference in thermal conditions between various test runs.

The drop off in opening pressure due to spring relaxation may be caused by excessive valve lift in the event of excessive discharge beyond rated flow. The compression screw can be adjusted to provide desire set pressure. However, this should be done for temporary relief. The relaxed spring should be replaced with a new one. Between initial and subsequent test runs, soft seat settles a little bit providing dropping off in opening pressure. However, three consecutive tests runs within opening pressure tolerance should indicate settling of the soft seat. Any drop in opening pressure can be corrected by turning compression screw clockwise and by verifying the opening pressure by test.

XI. REPLACEMENT PARTS, TOOLS AND SUPPLIES

The recommended replacement parts, tools and supplies are metal seated disc, spring soft seat, retaining ring and soft seat assembly tools. For replacement or

spare parts: State type, size, set pressure and fluid type. Refer to current Safety and Relief Valve catalog for more information, if necessary.

Component: Disc

VALVE TYPE	VWV816	VTT816	VRR816	WPP815A	WQQ815A	WRR815A	4266101	4266201	4266301	4266401	4266601	4266501
1541D	X											
1541E		X										
1541F			X									
1541G				X								
1541H					X							
1541J						X						
1543D	X											
1543E		X										
1543F			X									
1543G				X								
1543H					X							
1543J						X						
2471D	X											
2471E		X										
2471F			X									
2471G				X								
2471H					X							
2471J						X						
2478D							X					
2478E								X				
2478F									X			
2478G										X		
2478H											X	
2478J												X

Component: Soft Seat Disc

VALVE TYPE	4263701	4264701	4264801	4264901	4265001	4265101	4266601	4266701	4266801	4266901	4267001	4267101
1541D	X											
1541E		X										
1541F			X									
1541G				X								
1541H					X							
1541J						X						
1543D	X											
1543E		X										
1543F			X									
1543G				X								
1543H					X							
1543J						X						
2471D	X											
2471E		X										
2471F			X									
2471G				X								
2471H					X							
2471J						X						
2478D							X					
2478E								X				
2478F									X			
2478G										X		
2478H											X	
2478J												X

Component: Retainer Ring

VALVE TYPE	2091156	2091157	2091158	2091159	2091161	2091163	2091155	2091160	2091162
1541D	X								
1541E		X							
1541F			X						
1541G				X					
1541H					X				
1541J						X			
1543D	X								
1543E		X							
1543F			X						
1543G				X					
1543H					X				
1543J						X			
2471D	X								
2471E		X							
2471F			X						
2471G				X					
2471H					X				
2471J						X			
2478D							X		
2478E	X								
2478F		X							
2478G			X						
2478H								X	
2478J									X

Component: Adjusting Ring Pin (2)

VALVE TYPE	4040703	4040701	4040704	4040705	4040702	
1541D	X					
1541E	X					
1541F		X				
1541G			X			
1541H				X		
1541J					X	
1543D	X					
1543E	X					
1543F		X				
1543G			X			
1543H				X		
1543J					X	
2471D		X				
2471E	X					
2471F	X					
2471G				X		
2471H					X	
2471J						X
2478D		NONE				
2478E		NONE				
2478F		NONE				
2478G		NONE				
2478H		NONE				
2478J		NONE				

Component: Spring

VALVE TYPE	
1541D	
1541E	
1541F	
1541G	SELECT
1541H	SPRING
1541J	FROM BRONZE
1543D	SPRING CHART
1543E	S-1 PAGE S1-21
1543F	THROUGH PAGE
1543G	S1-35
1543H	
1543J	
2471D	
2471E	
2471F	
2471G	
2471H	
2471J	
2478D	
2478E	
2478F	
2478G	
2478H	
2478J	

Component: Spring Washers (2)

VALVE TYPE	VBG906	VBA906A	VAW906A	VBH906A	VAL906A	VBF906A	VBG906B	VBS906	VBA906	VAW906	VBH906	VAL906	VBF906
1541D	X												
1541E		X											
1541F			X										
1541G				X									
1541H					X								
1541J						X							
1543D	X												
1543E		X											
1543F			X										
1543G				X									
1543H					X								
1543J						X							
2471D	X												
2471E		X											
2471F			X										
2471G				X									
2471H					X								
2471J						X							
2478D							X	X					
2478E									X				
2478F										X			
2478G											X		
2478H												X	
2478J													X

NOTE (1): 2478D-1 SIZE 3/4"

Notes

Notes

CONSOLIDATED®

Sales Offices

UNITED STATES

Alexandria Operation

La. Highway 3225 at U.S. Hwy. 167 North
P.O.Box 1430
Alexandria, LA 71309-1430
Telephone (318) 640-2250
Telex 586423
Rapifax (318) 640-6222

Northern Region

3201 North Wolf Road
Franklin Park, Illinois 60131
Telephone (708) 451-3913
Rapifax (708) 451-3997

Southern Region

16503 Park Row
Houston, Texas 77084
Telephone (713) 579-8720
Rapifax (713) 579-7844

CANADA

Dresser Canada, Inc.
Valve & Controls Division
5010 North Service Road
Burlington, Ontario
L7L 5R5 Canada
Telephone (905) 335-3529
Rapifax (905) 336-7628

JAPAN

Dresser Japan, Ltd.
Industrial Valve Operation
Room 405, Maersk Bldg.
18, Nihon-Odori, Naka-Ku.
Yokohama 231 Japan
Telephone (011-81) 45-651-5601
Rapifax (011-81) 45-651-5606

MEXICO

Masoneilan Internacional S.A. de C.V.
Av. Henry Ford No. 114
Apartado Postal 572
54030 Tlalnepantla,
Mexico
Telephone (011-525) 310-9863
Rapifax (011-525) 310-5584

SAUDI ARABIA

Dresser Al Rushaid Valve & Instrument Co., Ltd.
P.O.Box 10145
Jubail Industrial City 31961
Kingdom of Saudi Arabia
Telephone (011-966) 3-341-0278
Telex (928) 832108
Rapifax (011-966) 3-341-7624

SOUTH AFRICA

Dresser Limited
Valve & Controls Division
P.O. Box 2234
16 Edendale Road
Eastleigh, Edenvale 1610
Transvaal, South Africa
Telephone (011-27) 11-452-1550/1-7
Rapifax (011-27) 11-452-2903

SWITZERLAND

Dresser Europe, S.A.
Industrial Valve Operation
Badernerstrasse 156
P.O. Box 369
CH-8021 Zurich
Switzerland
Telephone (011-411) 241-0533
Telex (845) 812429
Rapifax (011-411) 241-4218

UNITED KINGDOM

Dresser U.K., Ltd.,
Industrial Valve Operation
Trevithick Works
Gillibrands Estate
Skelmersdale, Lancashire
WN8 9TU England
Telephone (011-44) 695-24234
Telex (851) 627039
Rapifax (011-44) 695-20175

Masoneilan Division Dresser U.K., Ltd.
Controls House
Riverside Way
Uxbridge, Middlesex
UB8 2YF England
Telephone (011-44) 895-258161
Telex (851) 935174
Rapifax (011-44) 895-234318

VENEZUELA

RIESE & CIA S.A.
Apartado 372
Caracas, Venezuela
Telephone (011-582) 541-3812 / 541-38
Telex (395) 24796
Rapifax (011-582) 545-2702

Note: Numbers in () are codes to be used for calling from the U.S.A.



DRESSER VALVE AND CONTROLS DIVISION

Industrial Valve North American Operations
Alexandria, Louisiana