



1541/1543 Series - Maintenance Manual

Consolidated® Safety Valve



Conversion Table

All the USCS values are converted to Metric values using the following conversion factors:

USCS Unit	Conversion Factor	Metric Unit
in.	25.4	mm
lb.	0.4535924	kg
in ²	6.4516	cm ²
ft ³ /min	0.02831685	m ³ /min
gal/min	3.785412	L/min
lb/hr	0.4535924	kg/hr
psig	0.06894757	barg
ft lb	1.3558181	Nm
°F	5/9 (°F-32)	°C

Note 1: Multiply USCS value with Conversion Factor to get Metric value.

NOTICE

For valve configurations not listed in this manual, please contact your local Greentag™ Center for assistance.

Table of Contents

Section	Subject	Page No
I.	Product Safety Sign and Label System	4
II.	Safety Precautions	5
III.	Safety Notice	5
IV.	Warranty Information.....	6
V.	Valve Terminology	7
VI.	Handling, Storage and Pre-installation	8
VII.	Pre-Installation and Installation Instructions	8
VIII.	Design Features & Nomenclature	9
IX.	Introduction	9
X.	Consolidated® Safety Valve Type 1541/1543.....	10
XI.	Operating Principles.....	11
XII.	General Planning for Maintenance.....	11
XIII.	Disassembly of 1541/1543 Series Safety Valves	12
XIV.	Maintenance Instructions	12
A.	General	12
B.	Lapping Procedure.....	12
XV.	Inspection and Part Replacement.....	13
1.	Metal Seat Disc	13
2.	Soft Seat Disc	13
3.	Lower Adjusting Ring.....	14
4.	Upper Adjusting Ring.....	14
5.	Base.....	14
XVI.	Reassembly of 1541/1543 Series Safety Valves	15
XVII.	Setting, Testing and Adjustment.....	16
XVIII.	Trouble-Shooting	17
XIX.	Replacement Parts Planning	19
A.	Basic Guidelines	19
B.	Identification and Ordering Essentials	20
XX.	Genuine Dresser Parts	20
XXI.	Field Service, Repair and Training Program.....	21
A.	Factory Setting vs. Field Setting.....	21
B.	Field Service	21
C.	Factory Repair Facilities	21
D.	Safety Valve Maintenance Training	21
	Sales Office Locations	22

I. Product Safety Sign and Label System

If and when required, appropriate safety labels have been included in the rectangular margin blocks throughout this manual. Safety labels are vertically oriented rectangles as shown in the *representative examples* (below), consisting of three panels encircled by a narrow border. The panels can contain four messages which communicate:

- The level of hazard seriousness
- The nature of the hazard
- The consequence of human, or product, interaction with the hazard.
- The instructions, if necessary, on how to avoid the hazard.

The top panel of the format contains a signal word (DANGER, WARNING, CAUTION or ATTENTION) which communicates the level of hazard seriousness.

The center panel contains a pictorial which communicates the nature of the hazard, and the possible consequence of human or product interaction with the hazard. In some instances of human hazards the pictorial may, instead, depict what preventive measures to take, such as wearing protective equipment.

The bottom panel may contain an instruction message on how to avoid the hazard. In the case of human hazard, this message may also contain a more precise definition of the hazard, and the consequences of human interaction with the hazard, than can be communicated solely by the pictorial.

① **DANGER** – Immediate hazards which **WILL** result in severe personal injury or death.

② **WARNING** – Hazards or unsafe practices which **COULD** result in severe personal injury or death.

③ **CAUTION** – Hazards or unsafe practices which **COULD** result in minor personal injury.

④ **ATTENTION** – Hazards or unsafe practices which **COULD** result in product or property damage



II. Safety Precautions



Follow all plant safety regulations, but be sure to observe the following:

- Always lower the working pressure before making any valve adjustment. When making ring adjustments, always gag the valve before making the adjustment. This will avoid possible personal injury.
- Do not stand in front of the discharge side of a safety valve when testing or operating.
- Hearing and eye protection should be used when testing or operating a valve.
- Wear protective clothing. Hot water can burn and superheated steam is not visible.
- When removing the safety valve during disassembly, stand clear and/or wear protective clothing to prevent exposure to splatter, or any corrosive process medium, which may have been trapped inside the valve. Ensure the valve is isolated from system pressure before the valve is removed.
- Exercise care when examining a safety valve for leakage.
- Prior to each actuation, assure that no personnel are near the valve. Steam escaping from the valve during actuation can possibly cause personal injury.
- When popping a safety valve for the first time, or after refurbishment, always be prepared to actuate the valve with the lever while standing in a safe place away from the valve. This may be done by fixing a rope to the lever for actuating the valve from a distance.
- Striking a valve which is under pressure can cause premature actuation. Never tamper with the valve when system pressure is near the valve set pressure.
- Before performing any machining on valve parts, consult Dresser Consolidated® or its authorized representative. Deviation from critical dimensions can adversely affect valve performance.

III. Safety Notice

Proper installation and start-up is essential to the safe and reliable operation of all valve products. The relevant procedures recommended by Dresser Consolidated®, and described in these instructions, are effective methods of performing the required tasks.

It is important to note that these instructions contain various “safety messages” which should be carefully read in order to minimize the risk of personal injury, or the possibility that improper procedures will be followed which may damage the involved Dresser Consolidated® product, or render it unsafe. It is also important to understand that these “safety messages” are not exhaustive. Dresser Consolidated® can not possibly know, evaluate, and advise any customer of all of the conceivable ways in which tasks might be performed, or of the possible hazardous consequences of each way. Consequently, Dresser Consolidated® has not undertaken any such broad evaluation and, thus, anyone who uses a procedure and/or tool, which is not recommended by Dresser Consolidated®, or deviates from Dresser Consolidated® recommendations, must be thoroughly satisfied that neither personal safety, nor valve safety, will be jeopardized by the method and/or tools selected. Contact Dresser Consolidated® at (318) 640-6055, if there are any questions relative to tools/methods.

III. Safety Notice (Contd.)

The installation and start-up of valves and/or valve products may involve proximity to fluids at extremely high pressure and/or temperature. Consequently, every precaution should be taken to prevent injury to personnel during the performance of any procedure. These precautions should consist of, but are not limited to, ear drum protection, eye protection, and the use of protective clothing, (i.e., gloves, etc.) when personnel are in, or around, a valve work area. Due to the various circumstances and conditions in which these operations may be performed on Dresser Consolidated® products, and the possible hazardous consequences of each way, Dresser Consolidated® can not possibly evaluate all conditions that might injure personnel or equipment. Nevertheless, Dresser Consolidated® does offer certain

Safety Precautions, listed in Section II, for customer information only.

It is the responsibility of the purchaser or user of Dresser Consolidated® valves/equipment to adequately train all personnel who will be working with the involved valves/equipment. For more information on training schedules, call (318) 640-6054. Further, prior to working with the involved valves/equipment, personnel who are to perform such work should become thoroughly familiar with the contents of these instructions. Additional copies of these instructions can be purchased, at a minimal cost, by contacting Dresser Consolidated® (in writing) at P.O. Box 1430, Alexandria, LA 71309-1430, or by calling at (318) 640-2250, Fax (318) 640-6325.

IV. Warranty Information

Warranty Statement - Dresser warrants that its products and work will meet all applicable specifications and other specific product and work requirements (including those of performance), if any, and will be free from defects in material and workmanship. Refer to Dresser's Standard Terms of Sale, or specific contract for complete details on warranty and limitation of remedy and liability.

Defective and nonconforming items must be held for Dresser's inspection and returned to the original F.O.B. point upon request.

Incorrect Selection or Misapplication of Products - Dresser Consolidated® cannot be responsible for customer's incorrect selection or misapplication of our products.

Unauthorized Repair Work - Dresser Consolidated® has not authorized any non-Dresser affiliated repair companies, contractors or individuals to perform warranty repair service on new products or field repaired products of its manufacture. Therefore, customers contracting such repair services from unauthorized sources must do so at their own risk.

Unauthorized Removal of Seals - All new valves and valves repaired in the field by Dresser Field Service are sealed to assure the customer of our guarantee against defective workmanship. Unauthorized removal and/or breakage of this seal will negate our warranty.

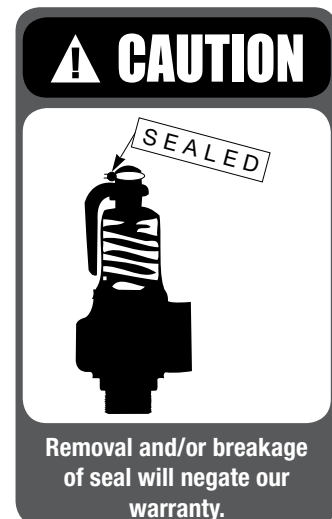

V. Valve Terminology

(Paraphrased from ASME's PTC 25)

- **Back Pressure**

Back pressure is the static pressure existing at the outlet of a safety valve device due to pressure in the discharge system.

- **Blowdown**

Blowdown is the difference between actual popping pressure of a safety valve and actual reseating pressure expressed as a percentage of set pressure, or in pressure units.

- **Bore Area**

Bore area is the minimum cross-sectional area of the seat bushing.

- **Bore Diameter**

Bore diameter is the minimum diameter of the seat bushing.

- **Built-Up Back Pressure**

Pressure existing at the outlet of a safety valve while it is open and flowing through a discharge system.

- **Chatter**

Chatter is abnormal, rapid reciprocating motion of the moveable parts of a safety valve, in which the disc contacts the seat.

- **Closing Pressure**

Closing pressure is the value of decreasing inlet static pressure at which the valve disc re-establishes contact with the seat, or at which lift becomes zero.

- **Disc**

A disc is the pressure containing moveable member of a safety valve which affects closure.

- **Inlet Size**

Inlet size is the nominal pipe size of the inlet of a safety valve, unless otherwise designated.

- **Leak Test Pressure**

Leak test pressure is the specified inlet static pressure at which a quantitative seat leakage test is performed in accordance with a standard procedure.

- **Lift**

Lift is the actual travel of the disc away from closed position when a valve is relieving.

- **Lifting Device**

A lifting device is a device for manually opening a safety valve, by the application of external force to lessen the spring loading which holds the valve closed.

- **Seat Bushing**

A seat bushing is the pressure containing element which constitutes the inlet flow passage and includes the fixed portion of the seat closure.

- **Outlet Size**

Outlet size is the nominal pipe size of the outlet passage of a safety valve, unless otherwise designated.

- **Overpressure**

Overpressure is a pressure increase over the set pressure of a safety valve, usually expressed as a percentage of set pressure.

- **Popping Pressure**

Popping pressure is the value of increasing inlet static pressure at which the disc moves in the opening direction at a faster rate as compared with corresponding movement at higher or lower pressures. It applies only to safety or safety relief valves on compressible fluid service.

- **Pressure Containing Member**

A pressure containing member of a safety valve is a part which is in actual contact with the pressure media in the protected vessel.

- **Pressure Retaining Member**

A pressure retaining member of a safety valve is a part which is stressed due to its function in holding one or more pressure containing members in position.

- **Rated Lift**

Rated lift is the design lift at which a valve attains its rated relieving capacity.

- **Safety Valve**

A safety valve is a pressure relief valve actuated by inlet static pressure and characterized by rapid opening or pop action.

- **Set Pressure**

Set pressure is the value of increasing inlet static pressure at which a safety valve displays the

V. Valve Terminology (Contd.)

operational characteristics as defined under “Popping Pressure.” It is one value of pressure stamped on the safety valve.

- **Seat**

A seat is the pressure containing contact between the fixed and moving portions of the pressure containing elements of a valve.

- **Seat Diameter**

Seat diameter is the smallest diameter of contact between the fixed and moving members of the pressure containing elements of a valve.

- **Seat Tightness Pressure**

Seat tightness pressure is the specific inlet static pressure at which a quantitative seat leakage test is performed in accordance with a standard procedure.

- **Simmer**

Simmer is the audible or visible escape of fluid between the seat and disc at an inlet static pressure below the popping pressure and at no measurable capacity. It applies to safety valves on compressible fluid service.

- **Warn**

See “Simmer” (definition above).

VI. Handling, Storage and Pre-installation

1. The valves should be stored in a dry environment to protect them from the weather.
2. The valves should never be subjected to sharp impact. This would be most likely to occur by bumping or dropping during loading or unloading from a truck or while moving with a power conveyor, such as a fork lift truck.
3. Meticulous care should be exercised to prevent dirt and other foreign materials from entering the inlet and outlet ports during storage as well as in installation.

VII. Pre-Installation and Installation Instructions

The safety valves must be connected in an upright vertical position directly to any equipment to be protected on equal size fittings no larger than the face-to-face dimension of an American extra heavy standard iron tee. Under no condition should a stop valve or other obstruction be placed between equipment and the safety valve.

Thoroughly clean the inlet of the valve before installation and be sure that no pipe thread compound gets into the bore of the valve during installation. Do not use excessive wrenching force that may distort the hex on the valve base. The valve must not be tightened by means of a pipe screwed into the outlet.

Each valve should have its own independent discharge piping system, which in no case should be smaller than

the valve outlet. If the discharge piping from one or more valves is manifolded together, in no case may the cross-section area of the discharge be less than the combined area of the valve outlets to which they are connected. As required, drainage should be provided for the discharge piping to prevent the accumulation of condensate in the valve body above the seat. The effect of discharge pipe length can be evaluated by any standard fluid flow calculations. Any discharge piping that appears excessive should be reviewed by calculation. The valve at all times should be free from external stresses transmitted from discharge piping. No alterations to discharge should be made without expert advice.

VIII. Design Features & Nomenclature

Consolidated® Bronze Safety Valves represent nearly a century of design, development and production experience. These valves are intended for overpressure protection of watertube boilers, firetube boilers, air tanks, other air systems and non-corrosive gases. For more detailed information on valve applications and features, see 1541/1543_Catalog. Manufacturing and testing of Consolidated® Bronze Safety Valves are controlled in accordance with Dresser® Consolidated's Quality Control Program. Consolidated® Safety Valves are approved by ASME B&PV Codes, Section I and VIII. Rigid Dresser quality control provides the user assurance that Consolidated® Bronze valves are a quality product that has been designed, manufactured and tested to provide many years of consistent, dependable service.

Evidence of this quality is a **GREEN TAG**¹ certification attached to the valve following final test and inspection.

Our Green Tag serves as a reminder that each Consolidated® valve meets or exceeds the stringent performance and overpressure protection requirements set forth by the ASME, and backed by Dresser® Consolidated. In addition, the symbol also represents our Green Tag Center located across the U.S. These centers are fully certified by Dresser as Consolidated® valve assembly and repair facilities. They also meet or exceed the standards of ASME and the National Board. For more information on the Green Tag Program, consult our factory.

Note 1: Trademark of Dresser Industries, Inc.

IX. Introduction

A safety valve is a key safety device that protects against catastrophic pressure vessel failure. However, if it is not properly installed, maintained, operated and repaired, the pressure vessel is like a potential bomb. For example;

A 30 gallon (114 ltr.) hot water tank at 90 psig (6.21 barg) has 3,138,400 ft-lb (4,255,100 Nm) of energy to flash its water into steam at 330°F (165.6°C) if liberated by rupture. Energy of a pound (0.45 kg) of three common explosives is:

Black powder	906 ft-lb (1228 Nm)
Smokeless powder	1,260 ft-lb (1,708 Nm)
Nitroglycerin	2,000,000 ft-lb (2,711,636 Nm)

On this basis, the 30 gallon (114 ltr.) tank is equivalent to about 1.5 lb. (0.68 kg) of nitroglycerin. Catastrophes, of course, are not the only loss exposure from improper safety-valve operation. Overpressure can rupture tubing and blow out packing. Improperly maintained safety valves, at times, may relieve at too low of a pressure or may leak, so the boiler never reaches the desired pressure or full efficiency. The result of these problems is unscheduled downtime. In summary, proper installation, maintenance and repair is as important as buying of a reliable valve. This manual therefore provides instructions for installation, maintenance and repair of Consolidated® Bronze Safety Valves.

X. Consolidated® Safety Valve Type 1541/1543

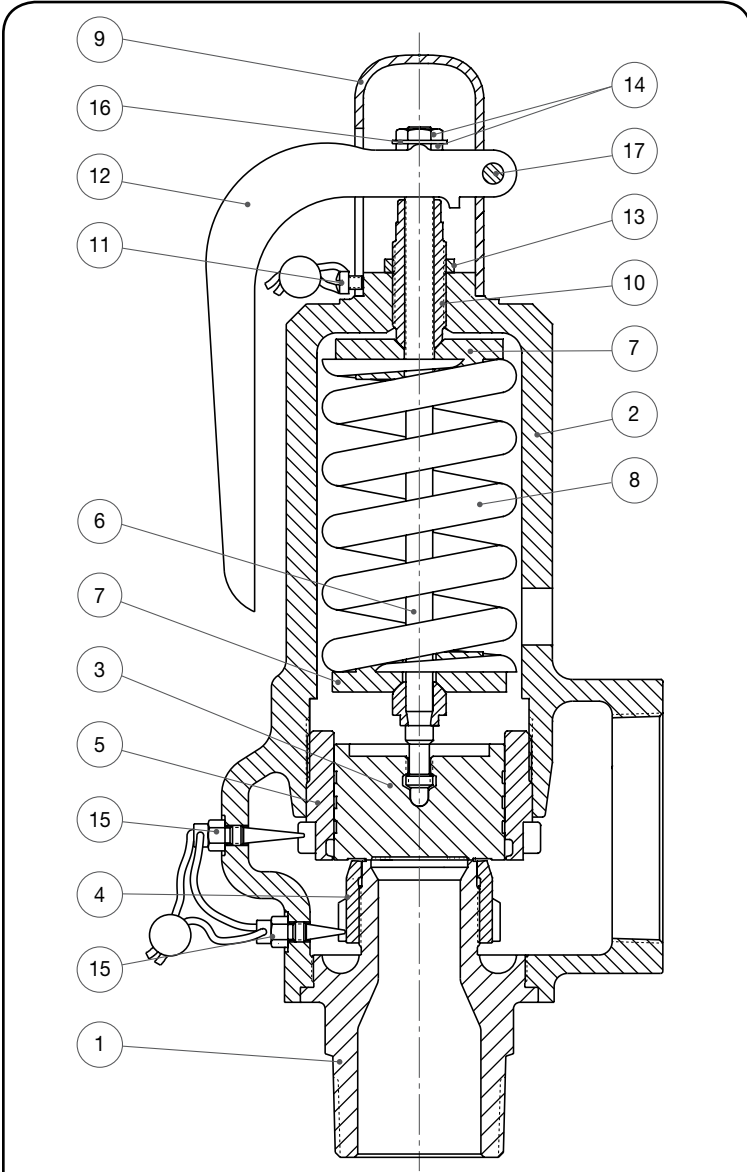

Figure 1: 1541/1543 Metal Seat Design

Part No.	Nomenclature
1	Base
2	Bonnet
3	Disc
4	Lower Adjusting Ring
5	Upper Adjusting Ring
6	Spindle
7	Spring Washer
8	Spring
9	Cap
10	Compression Screw
11	Cap Screw
12	Lever
13	Compression Screw Nut
14	Lifting Washer Nut
15	Adjusting Ring Pin
16	Lifting Washer
17	Lever Pin
18	Seat Washer (Soft Seat)
19	Soft Seat Retainer Ring (Soft Seat)
20	Lift Limiter (5 to 15 psig Only)

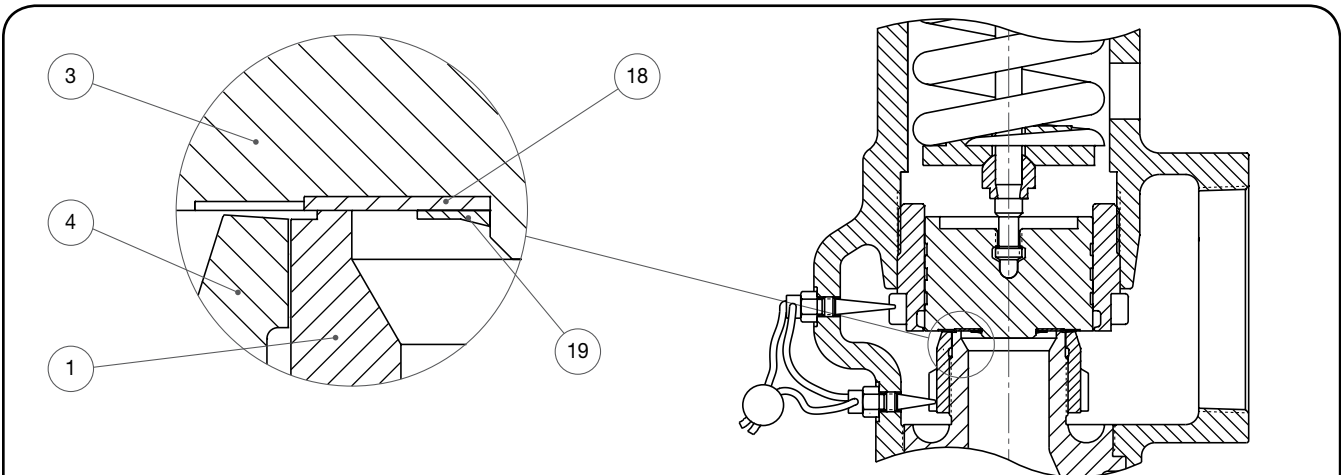

Figure 2: 1541/1543 Soft Seat Design

XI. Operating Principles

If a safety valve is subjected to pressure at or near its set pressure, it will tend to weep or simmer and deposits can accumulate in the seat and disc area. Eventually, this can cause the valve to freeze closed and thereafter the valve could fail to open at the set pressure.

To help prevent valve from weeping or simmering, it is important that the pressure differential between the valve set pressure and the boiler or pressure vessel operating pressure is sufficiently large to prevent the valve from weeping or simmering.

To minimize operational problems, the user must consider not only normal operating conditions of the

fluids (liquids or gases), pressures and temperatures, but also startup and shutdown conditions, process upsets and anticipated ambient conditions, instrument response time, pressure surges due to quick-closing valves, etc. When such conditions are not considered, the safety valve may become, in effect, a pressure controller, a duty for which it was not designed. Additional consideration should be given to the hazard and pollution associated with the release of the fluid. Large differentials may be appropriate for fluids which are toxic, corrosive, or exceptionally valuable.

XII. General Planning for Maintenance

Safety valves require periodic inspection and tests by qualified persons to keep them working properly. There is a natural reluctance to test valve while boilers are in operation. Yet, this is the best way to be sure the valves will function properly. The most positive test is to gradually increase boiler pressure until the valve or valves pop or until the maximum allowable working pressure is reached (pressure test).

The testing frequencies of safety valves will vary from plant to plant due to operating conditions. However, under normal conditions, the following schedule is recommended:

- Low pressure heating boilers: Manually tested not less than once each month, pressure tested once each year.
- Power boilers when the maximum allowable working pressure is up to 400 psig (27.58 barg); Manually tested not less than once each month, pressure tested once each year.

When they are tested manually, the levers should be lifted so as to raise the disc as high as possible to help flush out any deposits or foreign material that may accumulate in the seats or disc areas.

This is especially important on new installations because the boiler and piping systems may not have been thoroughly cleaned before the boiler was put into operation. Do not attempt to lift the lever unless there is pressure in the boiler at least equal to 75% of the stamped opening pressure of the safety valve.

When manually lifting the valve disc, just cracking it open slightly to permit the flow of steam or water is not advisable. If this is done, the seat may be damaged, causing the valve to leak when it is closed.

Problems encountered during visual inspection can be noted on the valve maintenance record to help with planned-outage maintenance. The valve record should include: nameplate data; date of last visual inspection, with results; date of operation, with results; date of testing, with results; date of last maintenance, repairs, and nature of repair work. The safety valve is part of the boiler system and must function as an integral part of it. ASME Boiler Code Section VII, recommended rules for care of power boilers, gives sound fundamentals on the coordination of all boiler devices.

XIII. Disassembly of 1541/1543 Series Safety Valves

1. Remove Cap or Cap-Lever Assembly.
2. Remove Lifting Washer and Lifting Washer Locknuts if applicable
3. Remove Lower Adjusting Ring Pin (Do not remove Upper Ring Pin).
4. Turn Lower Adjusting Ring to right slowly counting the number of notches moved until ring touches disc (note this location as lower adjusting ring should be set in same position on assembly).
5. Release Compression Screw Lock Nut and release spring compression by turning Compression Screw counter-clockwise and count number of turns to just relieve the compression.
6. With valve Base held in vise loosen Bonnet to Base connection (use strap wrench, do not use pipe wrench as this may crush the bonnet).
7. Remove Bonnet, Upper Adjusting Ring, Disc, Spindle, Spring and Spring Washer assembly from Base, holding Spindle to be sure Disc does not drop.
8. Remove Disc, Spindle, and Spring and Spring Washer from Bonnet.
9. The Upper Adjusting Ring need not be removed from Bonnet. However, if it is removed for cleaning or inspection, its position should be recorded. This can be done as follows:
 - a. Record position of Upper Adjusting Ring while ring pin is still engaged by measuring from bottom face of Ring to bottom face of Bonnet (see Figure 3).
 - b. Remove Upper Adjusting Ring Pin and remove Upper Adjusting Ring from Bonnet by turning ring in counter-clockwise direction.
10. Remove Disc from Spindle by engaging the threads and turning the Disc counter-clockwise.
11. If the Disc is soft seated and damaged, remove Retaining Ring with a sharp tool. Subsequently, remove Soft Seat. Retaining Ring and soft Seat should not be used again, instead new Retaining Ring and Soft Seat should be used.

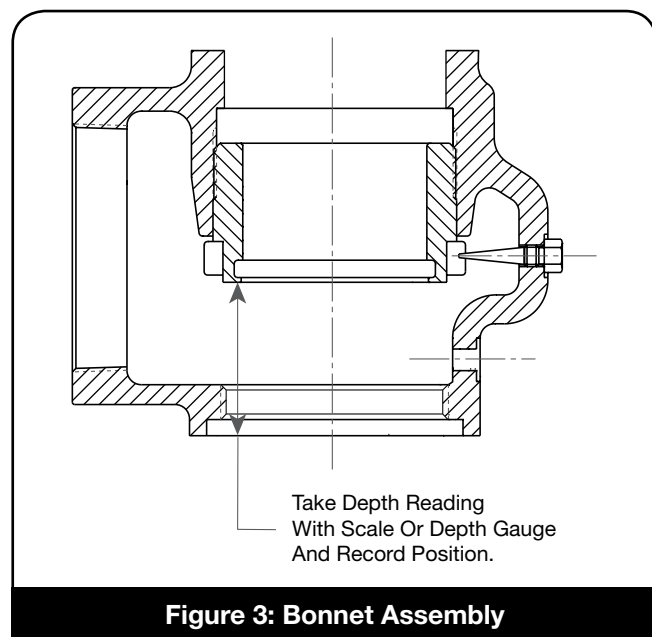

XIV. Maintenance Instructions

A. General

When a defective safety valve is encountered, immediate steps should be taken to have it replaced or repaired. These valves are delicate devices and they must be treated as such. It is a dangerous practice and false economy to have repairs carried out by persons who are not competent.

Remember that close tolerances are provided inside these valves for guides, disc, and seat. Anything that disturbs these tolerances can cause a malfunction of the valve. For instance, a wrench should never be used on the valve body; use the flat surfaces provided for this purpose. This will help avoid distorting the valve body, which could interfere with the clearances and tolerances of the internals.

If the repair causes any deviation from the original design, the valve may no longer be considered as being of the original type, since such changes could adversely affect the valve capacity and operation.

B. Lapping Procedure

Seating surfaces could be restored by lapping. This can be accomplished by lapping with a flat cast iron ring lap coated with Grade No. 1000 KWIK-AK-SHUN Silicon Carbide compound, or equivalent.

Lapping a flat seat is extremely simple. No special skill is required and the technique is readily apparent after a few minutes of actual lapping.

The following precautions and hints will enable anyone to do a "Professional" job of lapping seats:

XIV. Maintenance Instructions (Contd.)

- Keep the work clean.
- Always use a fresh lap. If signs of wearing (out of flatness) are evident, recondition the lap.
- Apply a very thin layer of compound to the lap. This will prevent rounding off the edges of the seat.
- Keep the lap squarely on the flat surface and avoid any tendency to rock the lap which will cause rounding of the seat.
- When lapping the base keep a firm grip on the lap or part to prevent the possibility of dropping it and damaging the seat.
- Lap, using a reciprocating motion in all directions, at the same time applying uniform pressure and rotating the lap or the part slowly. If reconditioning necessitates removing more than .010" (0.25 mm), replace the base.
- When lapping the disc seat, the lap should be held stationary and the disc moved as above. If reconditioning necessitates removing more than .010" (0.25 mm), replace the disc.
- Replace the compound frequently after wiping off the old compound, and apply more pressure to speed the cutting action of the compound.
- To check the seating surfaces, remove all compound from both the seat and the lap. Then shine up the seat with the same lap using the lapping motion described above. Alternatively, use polishing paper to shine up seating surface. Place polishing paper on a flat metallic surface. Rub part gently with rotating/reciprocating motion to shine-up. Low sections on the seating surface will show up as a shadow in contrast to the shiny portion. If shadows are present, further lapping is necessary, and only laps known to be flat should be used. Only a few minutes will be required to remove the shadows.
- When the lapping is completed, any lines appearing as cross scratches can be removed by rotating the lap, which has been wiped clean of compound, on the seat about its own axis.
- The seat should now be thoroughly cleaned with kerosene, light oil, or carbon tetrachloride, using a lint-free cloth or tissue paper.

XV. Inspection and Part Replacement

1. Metal Seat Disc Replacement Criteria:

Metal Seat Disc should be replaced:

- Seat Surface (Y) is nicked.
- Spindle bearing surface (Z) is galled or pitted.
- Exceeds dimensions mentioned in Table 1 and Figure 4.

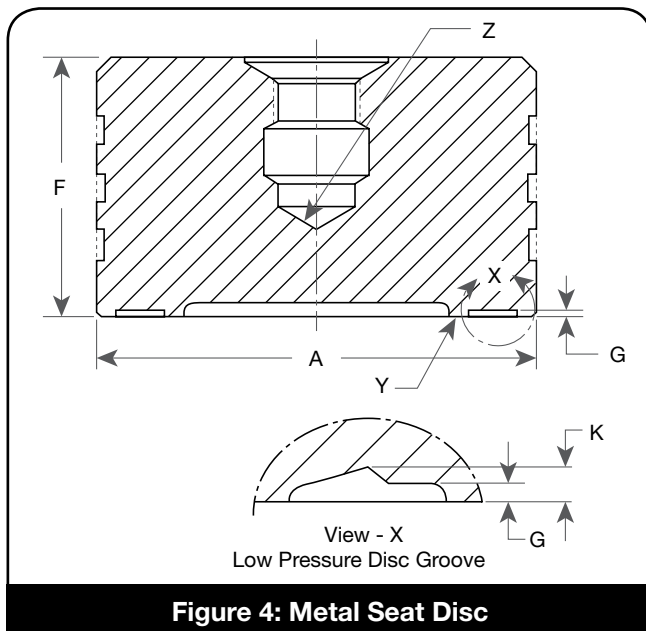

Figure 4: Metal Seat Disc

Table 1: Metal Seat Disc Replacement Criteria

Orifice	A +.000/-.002" (+0.00/-0.05 mm)		F ± .063" (± 1.59 mm)		G min.		K min.	
	in.	mm	in.	mm	in.	mm	in.	mm
D	.717	18.21	.562	14.27	.015	0.38	N/A	N/A
E	.955	24.26	.562	14.27	.015	0.38	N/A	N/A
F	1.194	30.33	.938	23.83	.015	0.38	N/A	N/A
G	1.528	38.81	1.063	27.00	.015	0.38	N/A	N/A
H-LP	1.911	48.54	1.125	28.58	.015	0.38	.044	1.12
H-HP	1.911	48.54	1.125	28.58	.015	0.38	N/A	N/A
J-LP	2.451	62.26	1.438	36.53	.015	0.38	.048	1.22
J-HP	2.451	62.26	1.438	36.53	.015	0.38	N/A	N/A

2. Soft Seat Disc Replacement Criteria:

Soft Seat Disc should be replaced:

- Spindle bearing surface (Z) is galled or pitted.
- Outside diameter exceeds A min. mentioned in Table 2 and Figure 5.

XV. Inspection and Part Replacement (Contd.)

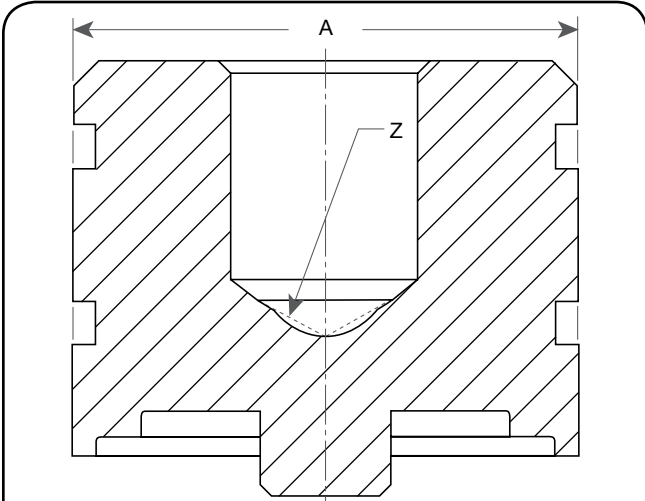

Figure 5: Soft Seat Disc

Table 2: Soft Seat Disc Critical Dimensions

Orifice	A $+0.000/-0.002$ " ($+0.00/-0.05$ mm)	
	in.	mm
D	.717	18.21
E	.955	24.26
F	1.194	30.33
G	1.528	38.81
H	1.911	48.54
J	2.451	62.26

3. Lower Adjusting Ring Replacement Criteria:

Lower Adjusting Ring (Figure 6) should be replaced:

- Threads (T) are torn, stripped or galled.
- Notches (N) are worn or missing.
- Outside diameter exceeds minimum dimension E in Table 3.

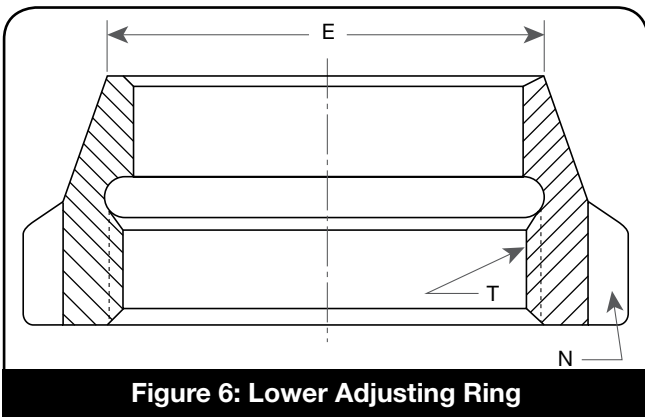

Figure 6: Lower Adjusting Ring

4. Upper Adjusting Ring Replacement Criteria:

Upper Adjusting Ring (Figure 7) should be replaced:

- Threads (T) are torn, stripped or galled.

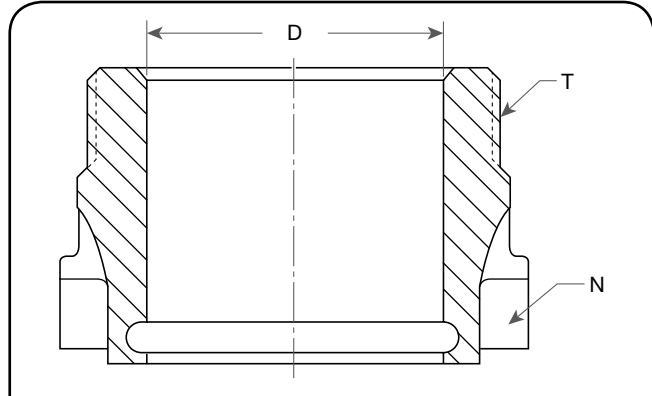

Figure 7: Upper Adjusting Ring

Table 3: Adjusting Ring Replacement Criteria

Orifice	Upper Adj. Ring		Lower Adj. Ring	
	D max.		E $\pm .002$ " (± 0.05 mm)	
	in.	mm	in.	mm
D	.722	18.34	.575	14.61
E	.960	24.38	.771	19.58
F	1.200	30.48	.963	24.46
G	1.536	39.01	1.232	31.29
H	1.919	48.74	1.542	39.17
J	2.459	62.46	1.977	50.22

- Threads (T) are worn or missing.
- Notches (N) are worn or missing.
- Inside diameter exceeds dimension D in Table 3.

5. Base Replacement Criteria:

Base (Figure 8) should be replaced:

- Seat Surface (X) is nicked.
- Threads (T) are torn, stripped or galled.

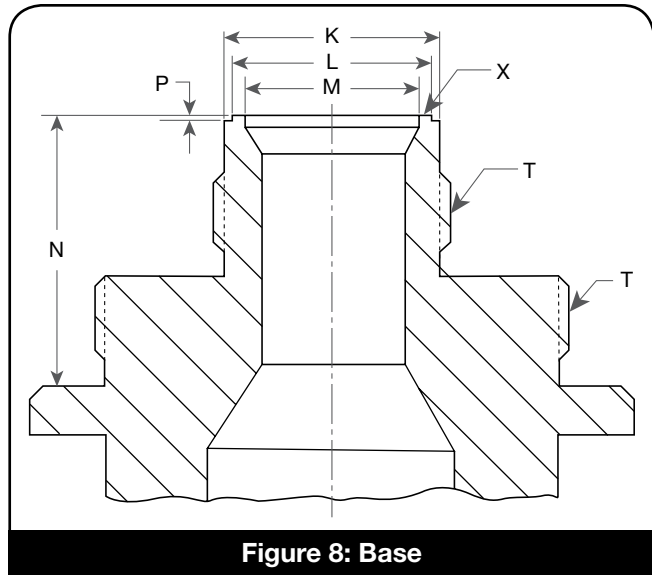

Figure 8: Base

XV. Inspection and Part Replacement (Contd.)

c. Dimensions in Table 4 (Figure 8) exceeds minimum values.

Replace all parts as needed. If any damage listed above is present, the part should be replaced or repaired per instruction. Other valve parts may be acceptable with

light corrosion, pitting, or minor damage of other types if it can be determined that it will not affect product performance. All o-rings and seals should be replaced each time the valve is disassembled.

Table 4: Base Replacement Criteria

Orifice	K ± .001" (± 0.03 mm)		L +.001/- .002" (+0.03/-0.05 mm)		M ± .002" (± 0.05 mm)		N ± .015" (± 0.38 mm)		P min.	
	in.	mm	in.	mm	in.	mm	in.	mm	in.	mm
D	.526	13.36	.487	12.37	.444	11.28	.781	19.84	.020	.508
E	.701	17.81	.640	16.26	.590	14.99	.781	19.84	.020	.508
F	.874	22.20	.802	20.37	.739	18.77	1.063	27.00	.020	.508
G	1.119	28.42	1.027	26.09	.945	24.00	1.156	29.36	.020	.508
H	1.399	35.53	1.294	32.87	1.180	29.97	1.313	33.35	.020	.508
J	1.795 ± .002	45.59 ± 0.05	1.634	41.50	1.512	38.40	1.531	38.89	.020	.508

XVI. Reassembly of 1541/1543 Series Safety Valves

1. Clean seats and all parts.
2. Assemble Lower Adjusting Ring to Base (top of Lower Adjusting Ring to be flush with seat).
3. Assemble Upper Adjusting Ring to Bonnet and reset Upper Adjusting Ring to its original position and assemble Upper Adjusting Ring Pin.
4. Lubricate Spindle Bearing with powdered graphite mixed with penetrating oil and thread disc on Spindle and assemble Spring and Spring Washers.
5. Insert Disc, Spindle, Spring and Spring Washer Assembly to Bonnet. If soft seated disc, see Step 11.
6. Holding Bonnet and Spindle (so that Disc will not drop) install Bonnet Assembly to Base. Tighten Bonnet on Base with strap wrench.
7. Assemble Compression Screw and re-establish spring compression by turning down the compression screw.
8. Re-establish position of Lower Adjusting Ring as follows:
 - a. Using a pointed tool turn the Lower Adjusting Ring to the right slowly, thus raising the ring until it touches the disc.
 - b. Then counting the notches turn the lower adjusting ring to the left, thereby lowering the ring, until the original position is established.
9. Test valve per instructions outlined under SETTING, TESTING AND ADJUSTMENT (Section XVII).
10. Install Lifting Washer and Locknuts, Cap and Lever. Make sure that Lifting Washer clears Lever by at least .063" (1.59 mm) when Lifting Lever is in free position. If screwed cap or packed lever construction, perform their installation.
11. Utilize following steps to assemble soft seated disc:
 - a. Clean disc, put it on a metallic plate (see Figure 9). Disc surface having spindle pocket will lie on the metal plate.

XVI. Reassembly of 1541/1543 Series Safety Valves (Contd.)

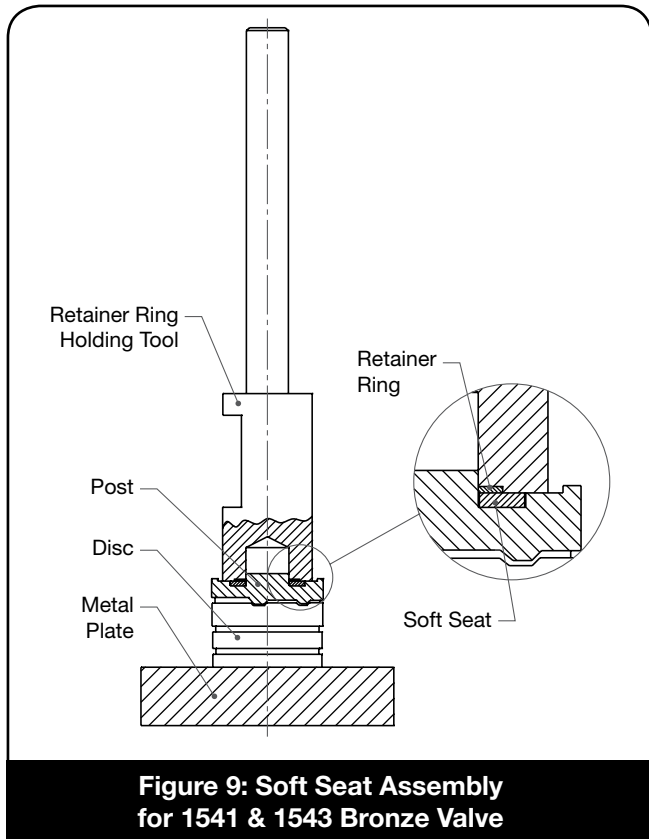

Figure 9: Soft Seat Assembly for 1541 & 1543 Bronze Valve

- b. Pick up an appropriate washer of the specified material. Clean this with lint free cloth. Inspect it for nicks, cuts, dents, concentric hole, etc.

(defective part should be rejected). Put Washer on the Disc (see Figure 9).

- c. Pick-up an appropriate Retaining Ring and tool assembly (see Table 5). Place Retaining Ring on the Disc. Subsequently put tool assembly in the mechanical press (not shown in Figure 9). Provide slight force to position Retaining Ring over the post. After removing force and inspecting proper positioning of Retaining Ring, press the Retaining Ring again, hard enough, to move Retaining Ring down to hold the seat washer tightly. A properly assembled soft seat will be somewhat compressed by Retaining Ring.

Table 5: Soft Seat Assembly Tool for 1541 & 1543 Bronze Valve

Orifice Size	Retainer Ring	Assembly Tool No.
D	2091156	7530141
E	2091157	7530142
F	2091158	7530143
G	2091159	7530144
H	2091161	7530145
J	2091163	7530146

XVII. Setting, Testing and Adjustment

Testing of safety valves is a necessary step, along with the maintenance and inspection. Set pressure, closing pressure (blowdown), lift are the three most important criteria. The three fundamental times when a safety valve should get a thorough test of the three operating characteristics mentioned are: when newly installed, so that operating characteristics can be properly adjusted; before planned maintenance, so that maintenance needs can be found; and after major maintenance involving machining or changing of parts.

To change the popping pressure of the valve, remove cap/cap-lever assembly. Loosen the locknut and turn the compression screw clockwise to increase pressure or counter-clockwise to decrease pressure.

Raising the popping pressure will increase the blowdown and likewise, lowering the popping pressure will decrease the blowdown. To correct or change the amount of blowdown, remove the upper ring pin and using a pointed

tool turn the upper adjusting ring 5 notches at a time. Turning the upper ring to the right will raise the ring and decrease the blowdown. Turning the upper ring to the left will lower the upper ring and increase the blowdown.

All blowdown adjustments should be made with the upper adjusting ring. If the upper ring is difficult to move, due to dirt being trapped between the ring and bonnet threads the ring can be freed by tapping lightly on the valve bonnet near the upper ring.

The lower adjusting ring should be adjusted one notch at a time. After putting in adjusting ring pins, the adjusting rings should be free to move within one notch. If the pins are too long, they will bend or break under thermal expansion. Furthermore, they could also cause misalignment and leakage. If they are too short the rings will move up and down. Check the relative contact of ring and ring pin after each adjustment.

XVII. Setting, Testing and Adjustment (Contd.)

It is possible that the first blow of a safety valve on steam may be a few pounds higher than after the valve is completely heated. Therefore, the valve should be popped a few times before any adjustments are changed.

The latest edition of the Code requires that all valves to be used for steam service must be tested on steam and not air or other media. In addition, all external adjustments must be sealed after testing and adjustment of set pressure. Seals shall be installed by the manufacturer at the time of initial shipment and after field adjustment or repair of the valves by either the manufacturer, his authorized representative, repairer, or the user. Seals shall be installed in such a manner as to prevent changing the adjustment without breaking the seal, and in addition, shall serve as a means of identifying the manufacturer, assembler, repairer, or user making the adjustment.

All safety valves for steam service are adjusted on steam at the factory, and all safety valves for air or gas service are adjusted on air. However, adjustments are necessary on the actual installation in order for the valves to have proper action and blowdown. This condition is due to the variations in size between the actual installation and the factory test drums and in outlet piping conditions.

All springs have factory established pressure ranges and must be changed if their pressure limits are exceeded. When it is desired to change the set pressure, the correct pressure-limit of the spring should be obtained from the factory.

XVIII. Troubleshooting

Certain troubles may develop through use or damage to working parts. The most common are simmering, leaking, chattering, and hang-up. See Table 6 for a summary of probable causes and corrective actions.

Simmering is defined as an audible escape of steam as pressure is raised to near the popping point. A slight simmer is not objectionable and only indicates slight irregularity of the seating surface. Larger amounts of simmer indicate seat damage, or that the Lower Adjusting is too low. If an attempt is made to eliminate simmer by adjustment of the Lower Adjusting Ring, it should be turned to the right one notch at a time, thereby raising the ring.

Leaking is the constant escape of steam at normal operating pressure below the closing pressure of the valve. It is caused by either damage to the seating surfaces or due to foreign matter being trapped. In the case of soft seated disc, leakage may occur due to nicks, cuts or dents on the soft seat. Furthermore, occasionally soft seat may get blown out during popping and relieving action. If hand lifting, wide open, does not give relief, the valve should be repaired at the first opportunity.

Other causes of leakage are interference of the lifting lever, such as the Lifting Washer riding on the Lever,

and improper installation of the discharge piping so as to introduce undue strain upon the valve. Chattering is a hammering action of a vibratory nature of the Disc on the Seat and must be stopped immediately or the seats will be ruined. To stop chattering, hold the valve open with the Lever until the steam pressure has been reduced several pounds.

Chattering is caused by the valve

1. Not having sufficient blowdown
2. Excessive back pressure from undersize discharge piping
3. Insufficient steam flow to the valve
4. Closing off of the vent hole in Bonnet

Hang-up occurs upon closing and is defined as leakage from the valve failing to shut off tightly. Incorrect blowdown or mechanical interference are the two principal causes. However, if the valve should hang-up, turning the Lower Adjusting Ring to the left one or two notches Chattering is a hammering action of a vibratory nature thereby lowering the ring should eliminate the trouble.

XVIII. Troubleshooting (Contd.)

Table 6: Valve Functional Problems and Corrective Actions

Problem	Probable Cause	Corrective Action
No action, valve does not go into full lift	A. Upper ring too high	A. Increase blowdown.
	B. Foreign material trapped between disc and guide	B. Disassemble valve and correct condition. Inspect system for cleanliness.
Hangup or failure to close from full lift	A. Lower ring too high	A. Move lower ring to left one notch per adjustment until problem is eliminated.
	B. Foreign material between disc and nozzle.	B. Disassemble valve and correct condition. Inspect system for cleanliness.
Excessive blowdown	A. Upper ring too low	A. Decrease blowdown.
	B. Exhaust pressure too high	B. Decrease exhaust pressure by increasing discharge area.
Valve leaks and/or exhibits erratic popping action	A. Damaged seat	A. Disassemble valve, tap seating surfaces, replace disc if required.
	B. Part misalignment	B. Disassemble valve, inspect contact area of disc and nozzle, lower spring washer or spindle, compression screw, spindle straightness, etc.
	C. Disc has insufficient rock	C. Disassemble valve and check disc rock.
	D. Discharge pipe binding on outlet	D. Correct as required.
	E. Soft seat damage	E. Replace soft seat and retaining ring if damaged.
Simmer	A. Lower ring too low	A. Adjust lower ring.
	B. Streamline vibrations	B. Investigate and correct cause.

XIX. Replacement Parts Planning

A. Basic Guidelines

The recommended spare parts/tools are spring, disc, soft seat, retaining ring and retaining ring assembly tools. When ordering replacement or spare parts, state type, size, and set pressure of the valve, and whether used with

steam or air. Refer to 1541/1543 Series Consolidated® Safety Valve catalog for more detailed information on parts descriptions and nomenclatures.

Component: Disc								
Valve Type	VWW816	VTT816	VRR816	WPP815A	4268702	WQQ815A	4322101	WRR815A
1541D	X							
1541E		X						
1541F			X					
1541G				X				
1541H					X	X		
1541J							X	X
1543D	X							
1543E		X						
1543F			X					
1543G				X				
1543H					X	X		
1543J							X	X

Component: Soft Seat Disc						
Valve Type	4263701	4264701	4264801	4264901	4265001	4265101
1541D	X					
1541E		X				
1541F			X			
1541G				X		
1541H					X	
1541J						X
1543D	X					
1543E		X				
1543F			X			
1543G				X		
1543H					X	
1543J						X

Component: Retainer Ring						
Valve Type	2091156	2091157	2091158	2091159	2091161	2091163
1541D	X					
1541E		X				
1541F			X			
1541G				X		
1541H					X	
1541J						X
1543D	X					
1543E		X				
1543F			X			
1543G				X		
1543H					X	
1543J						X

Component: Adjusting Ring Pin							
Valve Type	4040703	4040701	4040704	4040705	4040702		
1541D	X						
1541E	X	X					
1541F			X				
1541G				X			
1541H					X		
1541J							
1543D	X						
1543E	X						
1543F		X					
1543G			X				
1543H				X			
1543J					X		

Component: Spring Washers						
Valve Type	VBG906	VBA906A	VAW906A	VBH906A	VAU906A	4342602
1541D	X					
1541E		X				
1541F			X			
1541G				X		
1541H					X	
1541J						X
1543D	X					
1543E		X				
1543F			X			
1543G				X		
1543H						
1543J						X

XIX. Replacement Parts Planning (Contd.)

B. Identification and Ordering Essentials

When ordering service parts, please furnish the following information to ensure receiving the correct replacement parts:

Soft Seat Selection: See Table 7 below

Identify valve by the following nameplate data:

1. Size
2. Type
3. Temperature Class
4. Serial Number

Example:

Material	Temperature Range				Pressure Range			
	min.		max.		min.		max.	
	°F	°C	°F	°C	psig	barg	psig	barg
Viton A	-10	-23.3	400	204.4	5	0.34	300	20.68
Silicone	-75	-59.4	400	204.4	5	0.34	300	20.68
Teflon	-325	-198.3	406	207.8	151	10.41	300	20.68

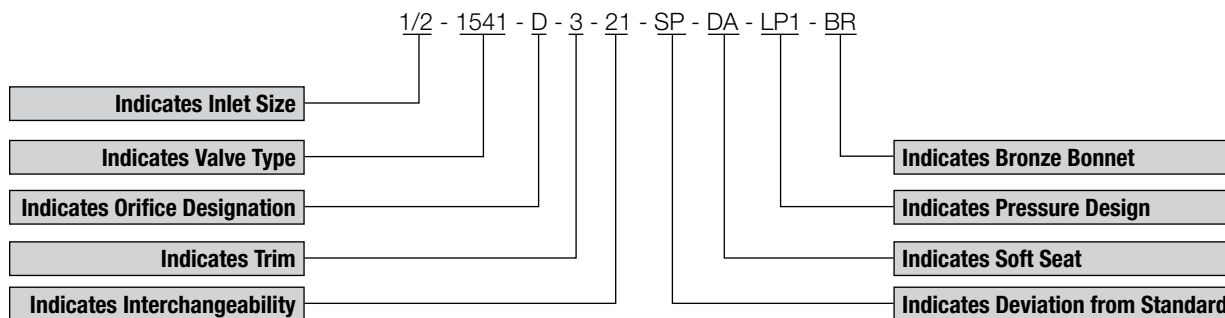

XX. Genuine Dresser Parts

The next time replacement parts are needed, keep these points in mind:

- Dresser Consolidated® designed the parts
- Dresser Consolidated® guarantees the parts
- Consolidated valve products have been in use since 1879
- Dresser Consolidated® has worldwide service
- Dresser Consolidated® has fast response availability for parts

XXI. Field Service, Repair and Training Program

A. Factory Setting vs. Field Setting

Every Consolidated® Safety Valve is set and adjusted on steam before shipment from the factory. Ring adjustments are made at the factory. However, it must be recognized that actual field operating conditions may vary considerably from factory test conditions.

Conditions beyond the manufacturer's control that affect Safety Valve operation include:

- Improper header nozzle design
- Quality of media being discharged
- Discharge piping stresses and back pressure
- Ambient temperature
- Shipping or storage damage
- Improper gagging
- Damage due to foreign material in the steam

Final Safety Valve adjustments made on the actual installation are the best means of ensuring that the valves perform in compliance with the ASME Boiler Code and/or other applicable code requirements.

B. Field Service

Utilities and Process Industries expect and demand service at a moment's notice. Consolidated® Field Service can be depended upon for prompt response, even in extreme off-hour emergency situations.

Dresser Consolidated® maintains the largest and most competent field service staff in the industry. Service Engineers are located at strategic points throughout the United States to respond to customer's requirements for service. Each Service Engineer is factory trained and long experienced in servicing Safety Valves. Dresser Consolidated® Service Engineers restore disc and seat bushing critical dimensions which affect valve performance, and are capable of modernizing valves in the field.

It is highly recommended that the professional talents of a Dresser Consolidated® Field Service Engineer be employed to make final field adjustments during the initial setting of all Consolidated® Safety Valves.

All Field Service Engineers' activities are coordinated from the Alexandria, Louisiana, Field Service Office. Upon receipt of a purchase order number authorizing the trip, the engineer is dispatched.

Reference: www.consolidatedvalve.com to locate your local Field Service representative.

C. Factory Repair Facilities

The factory at Alexandria, Louisiana maintains a Consolidated® Repair Center. The repair department, in conjunction with the manufacturing facilities, is equipped to perform specialized repairs and product modifications, e.g. bushing replacements, hydroset calibrations, electromatic relief valve repairs, etc.

Contact: Valve Repair Department at (318) 640-6057.

D. Safety Valve Maintenance Training

Rising costs of maintenance and repair in the Utility and Process Industries indicate the need for trained maintenance personnel. Dresser Consolidated® conducts service seminars that can help your maintenance and engineering personnel to reduce these costs.

Seminars, conducted either at your site, or at our Alexandria, Louisiana manufacturing plant, provide participants with an introduction to the basics of preventative maintenance. These seminars help to minimize downtime, reduce unplanned repairs and increase valve safety. While they do not make "instant" experts, they do provide the participants with "Hands On" experience with Consolidated Valves. The seminar also includes valve terminology and nomenclature, component inspection, trouble shooting, setting and testing, with emphasis on the ASME Boiler and Pressure Vessel Code.

For further information, **Please contact the Product Training Manager by fax at (318) 640-6325, or telephone (318) 640-6054.**

Sales Office Locations

UNITED STATES

Dresser Consolidated®
Dresser, Inc.
LA Hwy. 3225 @ US Hwy. 167N
P.O. Box 1430
Alexandria, LA 71309-1430
Telephone: + (1) 318 640 2250
Fax: + (1) 318 640 6325

Dresser Consolidated® Headquarters
10343 Sam Houston Park Drive
Suite 210
Houston, TX 77064
Telephone: +(1) 281 671 1640
Fax: +(1) 281 671 1735

Dresser Direct
1250 Hall Court
Deer Park, TX 77536
Telephone: + (1) 281 884 1000
Fax: + (1) 281 884 1010

Dresser Direct
905A Industrial Road
Clute, TX 77531
Telephone: + (1) 979 265 1309
Fax: + (1) 979 265 2514

Dresser Direct
4841 Leopard Street
Corpus Christi, TX 78408
Telephone: + (1) 361 881 8182
Fax: + (1) 361 881 8246

BRAZIL

Dresser Industria E Comercio Ltda
Rod. Presidente Dutra, KM 154, 7
Predio 18 - Pq Industrial CEP 12240-420
San Jose dos Campos, Sau Paulo, Brazil
Telephone: + (55) 11 2146 3600
Fax: + (55) 11 2146 3610

CHINA

Dresser Machinery (Suzhou) Co., Ltd.
81, Suhong Zhong Road
Suzhou Industrial Park
Suzhou, P.R. China 215021
Telephone: + (86) 512 6258 6500
Fax: + (86) 512 6258 8590

Dresser, Inc.
Suite 1703, Capital Mansion
6 Xinyuan S. Road, Chaoyang District
Beijing 100004 P.R. China
Telephone: + (86) 10 8486 4515
Fax: + (86) 10 8486 5305

FRANCE

Dresser Flow Technology Europe
Energy 5 - 130/190 Bd de Verdun
92413 Courbevoie Cedex, France
Tel: + (33) 1 49 04 90 00
Fax: + (33) 1 49 04 90 10

GERMANY

Dresser Valves Europe GmbH
Heiligenstrasse 75
41751 Viersen, Germany
Tel: + (49) 2162 8170 0
Fax: + (49) 2162 8170 280

INDIA

Dresser Valve India Pvt. Ltd.
305/306, "Midas", Sahar Plaza
Mathuradas VasANJI Road
J B Nagar, Andheri East, Mumbai, India 400 059
Telephone: + (91) 22 2 835 4790 / 838 1134
Fax: + (91) 22 2 835 4791

ITALY

Dresser Italia S.r.l.
Via Cassano 77
80020 Casavatore (Naples), Italy
Telephone: + (39) 081 7892 111
Fax: + (39) 081 7892 308

JAPAN

Dresser Japan, Ltd. (DJL)
20th Floor Marive East Tower
WBG 2-6 Nakase
Mihama-ku Chiba-shi
Chiba 261-7120 Japan
Telephone: + (81) 43 297 9211
Fax: + (81) 43 299 1115

KOREA

Dresser Korea, Inc.
Hyundai Swiss Tower, 17 Floor
143-40, Samsun-don Kangham-ku
Seoul 135-090, Korea
Telephone: + (82) 2 2274 0748
Fax: + (82) 2 2274 0720

Sales Office Locations

MALAYSIA

Dresser, Inc.
Asia Pacific Headquarters
Business Suite 19A-9-1, Level 9
UOA Centre, No. 19 Jalan Pinang
50450 Kuala Lumpur, West Malaysia
Telephone: + (60) 3 2161 0322
Fax: + (60) 3 2163 6312

MEXICO

Dresser De Mexico S.A. de C.V.
Henry Ford #114 Esq. Fulton
Fraccionamiento Industrial San Nicolas
C.P. 54030 Tlalnepantla, Estado de Mexico
Telephone: + (52) 55 5310 9863
Fax: + (52) 55 5310 4279

THE NETHERLANDS

Dresser Valves Europe GmbH
Steenhouwerstraat 11
NL-3194 AG Hoogvliet, The Netherlands
Telephone: + (31) 10 866 6538
Fax: + (31) 79 361 8995

RUSSIA

Dresser Europe
Derbenevskaya Ulitsa 1, Bldg. 3, Office 17
Moscow, Russian Federation 115 114
Telephone: + (7) 4955 851276
Fax: + (7) 4955 851279

SAUDI ARABIA

Dresser Al Rushaid Valve & Inst. Co. Ltd.
(DARVICO)
P. O. Box 10145
Jubail Industrial City 31961
Kingdom of Saudi Arabia
Telephone: + (966) 3 341 0278
Fax: + (966) 3 341 7624

SINGAPORE

Dresser Singapore, Pte. Ltd.
Dresser Flow Solutions
16 Tuas Avenue 8
Singapore 639231
Telephone: + (65) 6861 6100
Fax: + (65) 6861 7197

SOUTH AFRICA

Dresser International, Ltd., South Africa Branch
Dresser Flow Solutions
P. O. Box 2234, 16 Edendale Road
Eastleigh, Edenvale 1610
Republic of South Africa
Telephone: + (27) 11 452 1550
Fax: + (27) 11 452 2903

SPAIN

Dresser Italia S.r.l.
Via Cassano 77
80020 Casavatore (Naples), Italy
Telephone: + (39) 081 7892 111
Fax: + (39) 081 7892 308

SWITZERLAND

Dresser Valves Europe GmbH
Windensboden 23
CH-6345 Neuheim, Switzerland
Telephone: + (41) 41 755 27 03
Fax: + (41) 41 755 28 13

UNITED ARAB EMIRATES

Dresser International, Inc. - Middle East Operations
P. O. Box 61302
R/A 8, Blue Sheds JA01 & JA02,
Jebel Ali Free Zone
Dubai, United Arab Emirates
Telephone: + (971) 4 8838752
Fax: + (971) 4 8838038

UNITED KINGDOM

Dresser U.K. Limited
Dresser House
East Gillibrands
Skelmersdale, Lancashire
England WN8 9TU United Kingdom
Telephone: + (44) 1695 52600
Fax: + (44) 1695 52601

FOR YOUR GREEN TAG CENTER IN USA/CANADA
Visit www.dresser.com

or contact the locations listed above for international service.

Dresser® and Consolidated® are registered trademarks of Dresser, Inc.
Copyright 2007, Dresser, Inc.

About Dresser Consolidated®

Dresser Consolidated®, headquartered in Houston, Texas, has been an international leader in dependable pressure relief valves and solutions for more than 100 years. A business segment of Dresser, Inc., the company delivers the trusted expertise to provide and service reliable flow safety systems in critical applications around the world. www.dresser.com

About Dresser, Inc.

Dresser, Inc. is a leader in providing highly engineered infrastructure products for the global energy industry. The company has leading positions in a broad portfolio of products, including valves, actuators, meters, switches, regulators, piping products, natural gas-fueled engines, retail fuel dispensers and associated retail point-of-sale systems, and air and gas handling equipment. Leading brand names within the Dresser portfolio include Dresser Wayne® retail fueling systems, Waukesha® natural gas-fired engines, Masoneilan® control valves, Consolidated® pressure relief valves, and Roots® blowers. It has manufacturing and customer service facilities located strategically worldwide and a sales presence in more than 100 countries.

Dresser, Inc.

15455 Dallas Parkway
Addison, TX 75001
T. 972 361 9800
F. 972 361 9903



Consolidated

www.consolidatedvalve.com