

Consolidated[®]

INSTALLATION, OPERATION AND MAINTENANCE MANUAL

Consolidated[®] Safety Valve Type 1510, 1511 and 1811



Type
1510,
1511
&
1811



Industrial Valve Operation
Dresser Valve and Controls Division
Alexandria, Louisiana 71309-1430 (USA)

CON-11
Revised 9/93

- ①
DANGER — Immediate hazards which **WILL** result in severe personal injury or death.
- ②
WARNING — Hazards or unsafe practices which **COULD** result in severe personal injury or death.
- ③
CAUTION — Hazards or unsafe practices which **COULD** result in minor personal injury.
- ④
ATTENTION — Hazards or unsafe practices which **COULD** result in product or property damage.

Product Safety Sign and Label System



If and when required, appropriate safety labels have been included in the rectangular margin blocks throughout this manual. Safety labels are vertically oriented rectangles as shown in the *representative examples* (below), consisting of three panels encircled by a narrow border. The panels can contain four messages which communicate:

- The level of hazard seriousness
- The nature of the hazard
- The consequence of human, or product, interaction with the hazard.
- The instructions, if necessary, on how to avoid the hazard.

The top panel of the format contains a signal word (DANGER, WARNING, CAUTION or ATTENTION) which communicates the level of hazard seriousness.

The center panel contains a pictorial which communicates the nature of the hazard, and the possible consequence of human or product interaction with the hazard. In some instances of human hazards the pictorial may, instead, depict what preventive measures to take, such as wearing protective equipment.

The bottom panel may contain an instruction message on how to avoid the hazard. In the case of human hazard, this message may also contain a more precise definition of the hazard, and the consequences of human interaction with the hazard, than can be communicated solely by the pictorial.

①	②	③	④
			
<p>Do not remove bolts if pressure in line, as this will result in severe personal injury or death.</p>	<p>Know all valve exhaust/leakage points to avoid possible severe personal injury or death.</p>	<p>Wear necessary protective equipment to prevent possible injury.</p>	<p>Handle valve carefully. Do not drop or strike.</p>

CONSOLIDATED
SAFETY VALVE
TYPE *1510,1511

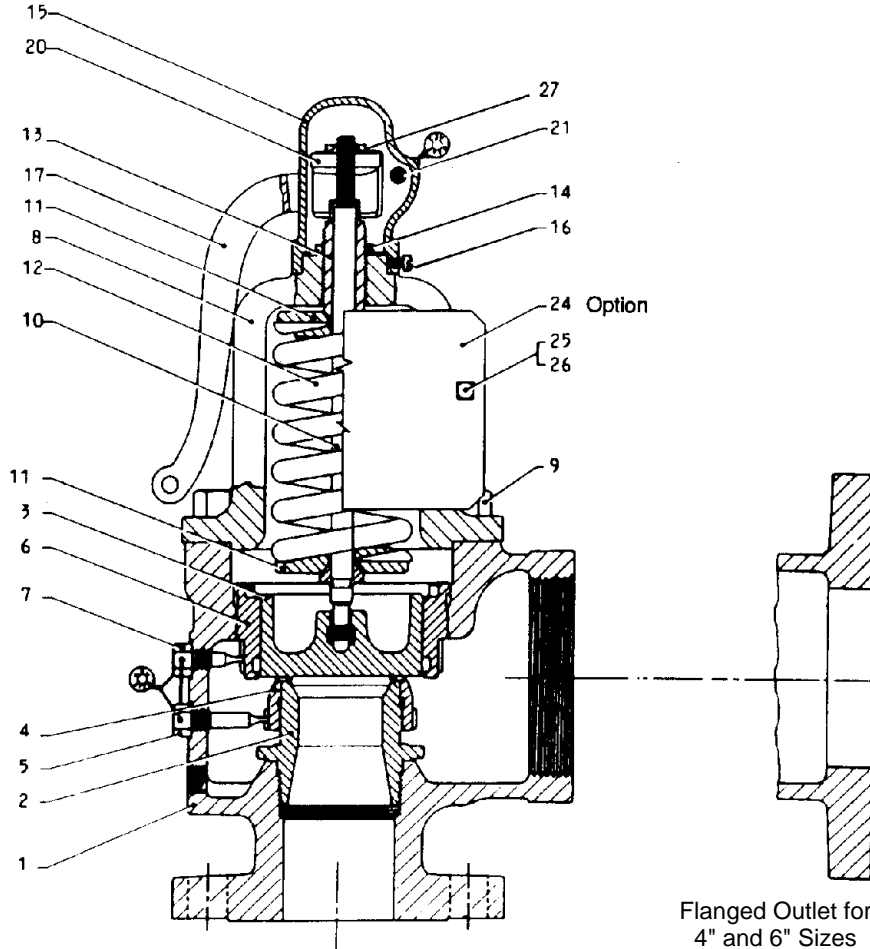

Part No.	Nomenclature
1	Base
2	Seat Bushing
3	Disc
4	Lower Adj. Ring
5	Lower Adj. Ring Pin
6	Upper Adj. Ring/ Guide
7	Upper Adj. Ring Pin
8	Yoke
9	Yoke Cap Screws
10	Spindle Assem.
11	Spring Washers
12	Spring
13	Compression Screw
14	Compression Screw Lock Nut
15	Cap
16	Cap Set Screw
17	Lever
18	Top Lever
19	Drop Lever
20	Release Nut
21	Lever Pin
22	Top Lever Pin
23	Drop Lever Pin
24	Spring Cover Option
25	Cover Bolt
26	Cover Nut
27	Release Lock Nut

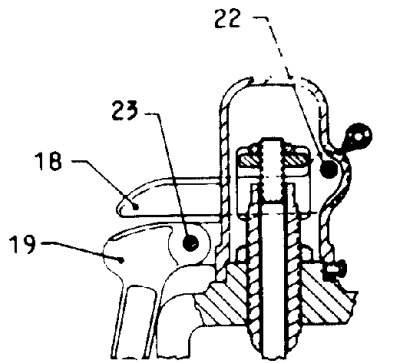

Cap and Lifting Lever Assembly
for 4" and 6" Sizes

* Type 1510 has a lift restrictor (not shown here) inside the spring and is limited to 15 psig set pressure. Except for that, it is identical to type 1511: unless otherwise noted, all references to type 1511 should be considered applicable to 1510 as well.

CONSOLIDATED SAFETY VALVE TYPE 1811

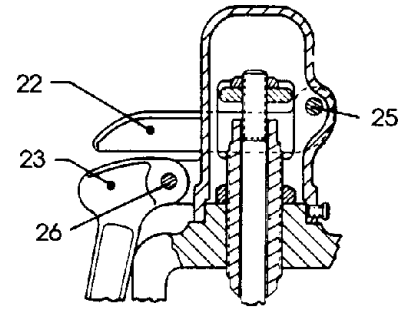

Cap and Lifting Lever Assembly
for 4" and 6" Sizes

Part No.	Nomenclature
1	Base
2	Seat Bushing
3	Disc
4	Lower Adj. Ring
5	Lower Adj. Ring Pin
6	Upper Adj. Ring/ Guide
7	Upper Adj. Ring Pin
8	Yoke
9	Base Stud
10	Stud Nut
11	Spindle
12	Bottom Spring Washer
13	Spring
14	Top Spring Washer
15	Compression Screw
16	Compression Screw Lock Nut
17	Cap
18	Cap Set Screw
19	Lever
20	Release Nut
21	Lever Pin
22	Top Lever
23	Drop Lever
24	Release Lock Nut
25	Top Lever Pin
26	Drop Lever Pin (Spring Cover Optional)

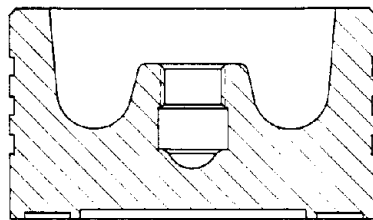
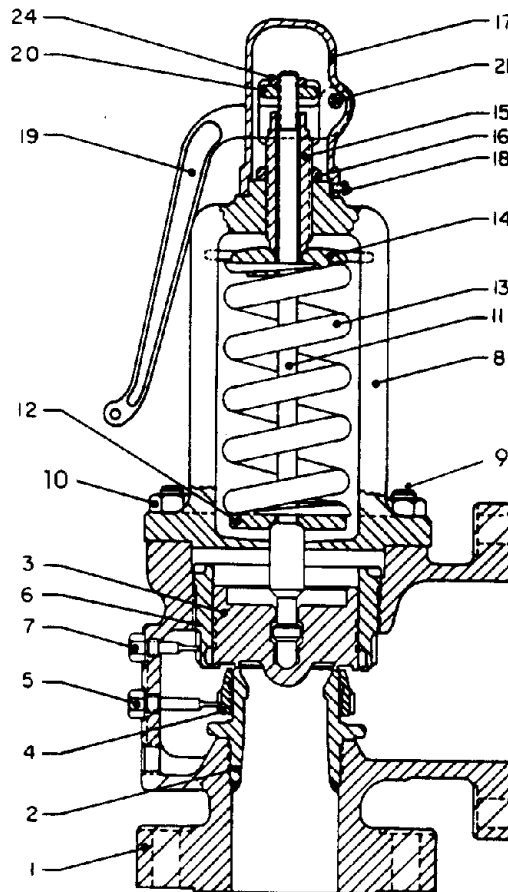

Flat Solid Disc
(Optional)

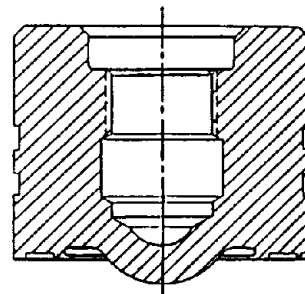

THERMOFLEX™ Disc Design
(Standard Since 1984)

Contents

<i>Section</i>	<i>Subject</i>	<i>Page</i>
I.	Safety Notice	6
II.	Safety Precautions	7
III.	Warranty Information	7
IV.	Introduction	8
V.	Safety Valve Terminology	9
VI.	Storage and Handling Prior to Installation	11
VII.	Recommended Installation Practices	
	A. General Requirements	12
	B. Outdoor Safety Valve Installation	12
VIII.	Hydrostatic Testing & Gagging	
	A. General Information	13
	B. Application of Test Gags (All Pressures)	13
IX.	Presetting the Adjusting Rings	14
X.	Disassembly for Repair	14
XI.	Inspection	
	A. General Information	15
	B. Specific Steps	15
XII.	Maintenance Instructions	
	A. General Information	22
	B. Machining	23
	C. Lapping Procedures	23
	D. Reconditioning a Ring Lap	24
	E. Spindle Runout	25
	F. Spring and Spring Washers	26
XIII.	Reassembly	26
XIV.	Steam Testing Procedures	27
XV.	EVT Testing	30
XVI.	Trouble Shooting the 1511 and 1811 Valves	31
XVII.	Maintenance Tools and Supplies	32
XVIII.	Service Parts Inventory Philosophy	33
XIX.	Recommended Spare Parts	
	A. 1511 Safety Valve	34
	B. 1811 Safety Valve	34
XX.	Retrofit - THERMOFLEX™ Disc	35
XXI.	Identification and Ordering Essentials	35
XXII.	Manufacturer's Field Service and Repair Program	
	A. Factory Setting vs. Field Setting	36
	B. Field Service	36
	C. Factory Repair Facilities	36
XXIII.	Safety Valve Maintenance Training	37
XXIV.	Genuine Dresser Parts	37
	Worldwide Service Locations	38
	Service Engineer Locations	39
	Worldwide Sales Office Locations	Back Cover

I. Safety Notice



Proper installation and start-up is essential to the safe and reliable operation of all valve products. The relevant procedures recommended by Dresser Industrial Valve Operation (DIVO), and described in these instructions, are effective methods of performing the required tasks.

It is important to note that these instructions contain various “safety messages” which should be carefully read in order to minimize the risk of personal injury, or the possibility that improper procedures will be followed which may damage the involved DIVO product, or render it unsafe. It is also important to understand that these “safety messages” *are not* exhaustive. DIVO can not possibly know, evaluate, and advise any customer of all of the conceivable ways in which tasks might be performed, or of the possible hazardous consequences of each way. Consequently, DIVO has not undertaken any such broad evaluation and, thus, anyone who uses a procedure and/or tool, which is not recommended by DIVO, or deviates from DIVO recommendations, must be thoroughly satisfied that neither personal safety, nor valve safety, will be jeopardized by the method and/or tools selected. If not so satisfied, contact DIVO (at 318/640-6055) if there are any questions relative to tools/methods.

The installation and start-up of valves and/or valve products may involve proximity to fluids at extremely high pressure and/or temperature. Consequently, every precaution should be taken to prevent injury to personnel during the performance of any procedure. These precautions should consist of, but are not limited to, ear drum protection, eye protection, and the use of protective clothing, (i.e., gloves, etc.) when personnel are in, or around, a valve work area. Due to the various circumstances and conditions in which these operations may be performed on DIVO products, and the possible hazardous consequences of each way, DIVO can not possibly evaluate all conditions that might injure personnel or equipment. Nevertheless, DIVO does offer certain Safety Precautions, listed on page 7 for customer information only.

It is the responsibility of the purchaser or user of DIVO valves/equipment to adequately train all personnel who will be working with the involved valves/equipment. For more information on training schedules, call 318/640-6054. Further, *prior* to working with the involved valves/equipment, personnel who are to perform such work should become thoroughly familiar with the contents of these instructions. Additional copies of these instructions can be purchased, at a minimal cost, by contacting DIVO (in writing) at P.O. Box 1430, Alexandria, LA 71309-1430, or by calling at 318/640-2250, Fax 318/640-6222.

II. Safety Precautions

Follow all plant safety regulations, but **be sure** to observe the following:

- **Always** lower the working pressure before making any valve adjustment. When making ring adjustments, always gag the valve before making the adjustment. This will avoid possible personal injury.
- Do **not** stand in front of the discharge side of a safety valve when testing or operating.
- Hearing and eye protection should be used when testing or operating a valve.
- Wear protective clothing. Hot water can burn and superheated steam is **not** visible.
- When removing the safety valve during disassembly, stand clear and/or wear protective clothing to prevent exposure to splatter, or any corrosive process medium, which may have been trapped inside the valve. Ensure the valve is isolated from system pressure **before** the valve is removed.
- Exercise care when examining a safety valve for leakage.
- Prior to each actuation, assure that no personnel are near the valve. Steam escaping from the valve during actuation can possibly cause personal injury.
- When popping a safety valve for the first time, or after refurbishment, always be prepared to actuate the valve with the lever while standing in a safe place away from the valve. This may be done by fixing a rope to the lever for actuating the valve from a distance.
- Striking a valve which is under pressure can cause premature actuation. **Never** tamper with the valve when system pressure is near the valve set pressure.
- Before performing any machining on valve parts, consult DIVO or its authorized representative. Deviation from critical dimensions can adversely affect valve performance.

III. Warranty Information

WARRANTY STATEMENT - Dresser warrants that its products and work will meet all applicable specifications and other specific product and work requirements (including those of performance), if any, and will be free from defects in material and workmanship. Refer to Dresser's Standard Terms of Sale, or specific contract for complete details on warranty and limitation of remedy and liability.

Defective and nonconforming items must be held for Dresser's inspection and returned to the original F.O.B. point upon request.

INCORRECT SELECTION OR MISAPPLICATION OF PRODUCTS - D.I.V.O. cannot be responsible for customer's incorrect selection or misapplication of our products.

UNAUTHORIZED REPAIR WORK - D.I.V.O. has not authorized any non-Dresser affiliated repair companies, contractors or individuals to perform warranty repair service on new products or field repaired products of its manufacture. Therefore, customers contracting such repair services from

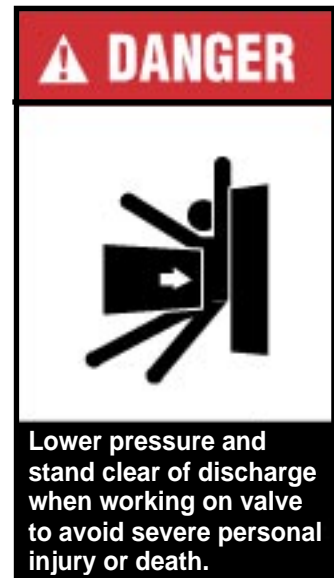

III. Continued

unauthorized sources must do so at their own risk.

UNAUTHORIZED REMOVAL OF SEALS - All new valves and valves repaired in the field by Dresser Field Service are sealed to assure the customer of our guarantee against defective workmanship. Unauthorized removal and/or breakage of this seal will negate our warranty.

IV. Introduction

The "safety valve" is the final safeguard between a controlled boiler and a catastrophic explosion. In an over-pressure situation, the pressure in the valve inlet increases until the force on the disc exerted by the system pressure equals the force exerted by the spring. This causes the safety valve to pop, or lift, relieving the excess steam until the system pressure is reduced to the desired level.

The Consolidated Safety Valve has been a leader in the industry since 1879, thus offering over a century of experience in design, engineering and product manufacture. Dresser's history of dependable and reliable valve service assures that today's products and designs are consistent with industry's current requirements. Rigid manufacturing standards controlled by an ASME approved Quality Control Program insure that each valve will be manufactured in accordance with established design criteria and tested for functional performance. This quality controlled manufacturing and test program assures that each valve manufactured will provide long and reliable service.

V. Terminology for Safety Valves

(Paraphrased from ASME's PTC 25.3)

- **Back Pressure**
Back pressure is the static pressure existing at the outlet of a safety valve device due to pressure in the discharge system.
- **Blowdown**
Blowdown is the difference between actual popping pressure of a safety valve and actual reseating pressure expressed as a percentage of set pressure, or in pressure units.
- **Bore Area**
Bore area is the minimum cross-sectional area of the seat bushing.
- **Bore Diameter**
Bore diameter is the minimum diameter of the seat bushing.
- **Built-Up Back Pressure**
Pressure existing at the outlet of a safety valve while it is open and flowing through a discharge system.
- **Chatter**
Chatter is abnormal, rapid reciprocating motion of the moveable parts of a safety valve, in which the disc contacts the seat.
- **Closing Pressure**
Closing pressure is the value of decreasing inlet static pressure at which the valve disc re-establishes contact with the seat, or at which lift becomes zero.
- **Disc**
A disc is the pressure containing moveable member of a safety valve which effects closure.
- **Inlet Size**
Inlet size is the nominal pipe size of the inlet of a safety valve, unless otherwise designated.
- **Leak Test Pressure**
Leak test pressure is the specified inlet static pressure at which a quantitative seat leakage test is performed in accordance with a standard procedure.
- **Lift**
Lift is the actual travel of the disc away from closed position when a valve is relieving.
- **Lifting Device**
A lifting device is a device for manually opening a safety valve, by the application of external force to lessen the spring loading which holds the valve closed.
- **Seat Bushing**
A seat bushing is the pressure containing element which constitutes the inlet flow passage and includes the fixed portion of the seat closure.
- **Outlet Size**
Outlet size is the nominal pipe size of the outlet passage of a safety valve, unless otherwise designated.
- **Overpressure**
Overpressure is a pressure increase over the set pressure of a safety valve, usually expressed as a percentage of set pressure.

V. (Continued)

- **Popping Pressure**
Popping pressure is the value of increasing inlet static pressure at which the disc moves in the opening direction at a faster rate as compared with corresponding movement at higher or lower pressures. It applies only to safety or safety relief valves on compressible fluid service.
- **Pressure Containing Member**
A pressure containing member of a safety valve is a part which is in actual contact with the pressure media in the protected vessel.
- **Pressure Retaining Member**
A pressure retaining member of a safety valve is a part which is stressed due to its function in holding one or more pressure containing members in position.
- **Rated Lift**
Rated lift is the design lift at which a valve attains its rated relieving capacity.
- **Safety Valve**
A safety valve is a pressure relief valve actuated by inlet static pressure and characterized by rapid opening or pop action.
- **Set Pressure**
Set pressure is the value of increasing inlet static pressure at which a safety valve displays the operational characteristics as defined under "Popping Pressure." It is one value of pressure stamped on the safety valve.
- **Seat**
A seat is the pressure containing contact between the fixed and moving portions of the pressure containing elements of a valve.
- **Seat Diameter**
Seat diameter is the smallest diameter of contact between the fixed and moving members of the pressure containing elements of a valve.
- **Seat Tightness Pressure**
Seat tightness pressure is the specific inlet static pressure at which a quantitative seat leakage test is performed in accordance with a standard procedure.
- **Simmer**
Simmer is the audible or visible escape of fluid between the seat and disc at an inlet static pressure below the popping pressure and at no measurable capacity. It applies to safety valves on compressible fluid service.
- **Warn**
See "Simmer" (definition above).

VI. Storage and Handling Prior to Installation

Safety valves should be stored in a dry environment to protect them from the weather. They should not be removed from the skids or crates until immediately prior to installation. Flange protectors and sealing plugs should remain installed until just prior to installation.

Safety valves, either crated or uncrated, should never be subjected to sharp impact. This would be most likely to occur by bumping or dropping during loading or unloading from a truck or while moving with a power conveyor, such as a fork lift truck. The valve, either crated or uncrated, should always be kept with the inlet down (i.e., never laid on its side), to prevent misalignment and damage to internals. Even crated valves should always be lifted with the inlet down.

Uncrated valves should be moved or hoisted by wrapping a chain or sling, around the discharge neck, then around the upper yoke structure, in such manner as will insure that the valve is in vertical position during lift, (i.e., not lifted in horizontal position). Never lift the full weight of the valve by the lifting lever. Never hook to the spring to lift. When safety valves are uncrated and the flange protectors removed, immediately prior to installation, meticulous care should be exercised to prevent dirt from entering the outlet port while bolting in place.

While hoisting to the installation, care should be exercised to prevent bumping the valve against steel structures and other objects.





VII. Recommended Installation Practices

A. General Requirements

The safety valve shall be connected to the boiler in a vertical position independent of any other steam connection, and attached as close as possible to the boiler. Intervening pipe or fittings shall be no longer than the face-to-face dimension of the corresponding tee fitting of the same diameter and pressure under the corresponding American Standard as set forth by the A.S.M.E.

Thoroughly clean the inlet of the valve before installation and be sure that the proper gasket is used. Tighten bolts evenly. Care should be taken when fastening bolts on cast iron flanges as cracking may result.

The valve shall be free from external stresses transmitted from the discharge piping. Figure 1 illustrates a recommended design allowing for ample clearance to take care of thermal expansion. The riser pipe should be large enough to accommodate the full capacity of the valve without causing steam to escape by flowing backward through the drip pan. In no case should the pipe connected to the valve be of a smaller size than the valve outlet.

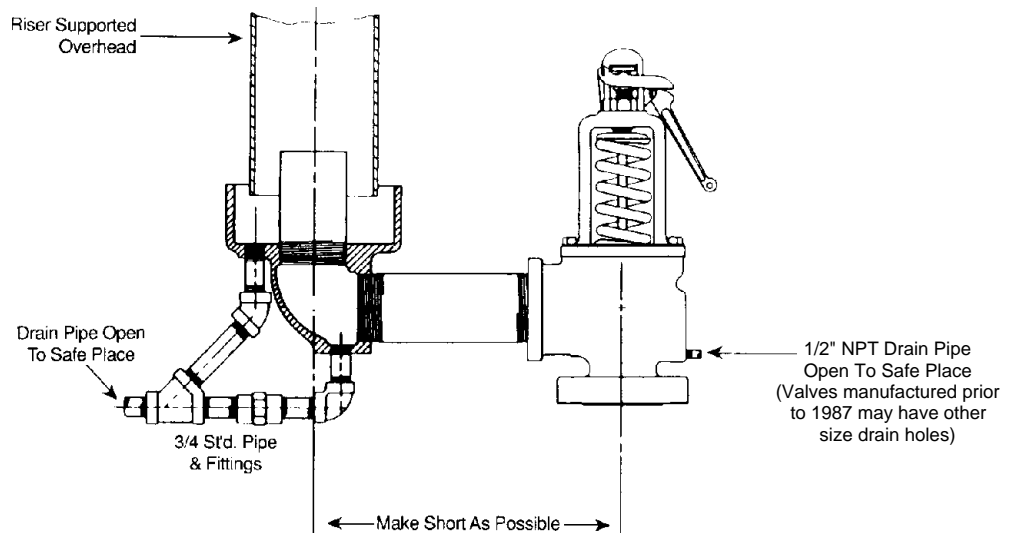

FIGURE 1
Recommended Installation for Discharge and Vent Piping

B. Outdoor Safety Valve Installation

When a safety valve is installed on an outdoor unit, it is advisable to insulate the valve body, including the inlet flange, up to the bottom of the yoke. The insulation will stabilize the valve body temperature preventing variation in the set pressure.

Valves must be readjusted if insulation is installed.

Weather shielding should be used to protect the spring and to minimize rain or snow from entering the valve body.

VIII. Hydrostatic Testing & Gagging

A. General Information

During any hydrostatic test all safety valves on the unit must be gagged. This gagging procedure prevents the possibility of damage to the safety valve internals in the event that the test pressure exceeds the safety valve set pressure.

When hydrostatic pressure will exceed the set pressure of the safety valve, it is recommended the valve be replaced with a blind flange during hydrostatic testing.

Probably the most common source of safety valve trouble is overgagging. During hydrostatic testing, and during safety valve setting, gags should be applied only hand tight. During setting, overgagging could cause damage to the seating surface and result in leakage. In applying gags, remember that the valve spring will hold the valve closed against its set pressure. The additional gag load applied should be only enough to insure that the valves do not lift at the expected over-pressure.

Gags should never be applied when the boiler is cold. The spindle of the safety valve expands considerably with the temperature increase as pressure is raised. If it is not free to expand with this temperature change, the spindle may be damaged.

Boiler pressure should be increased to 80% of the pressure of the low set valve before applying the gags.

Hand tighten the gags of drum and superheater valves with only a light force.

B. Application of Test Gags (All Pressures)

1. Refer to illustration at front of manual. Remove lever pin and lever. Then loosen cap screw and remove cap.
2. Center the test gag screw in the exposed end of the spindle and hook the legs of gag under the sides of the yoke as shown in Figure 2.

Do not apply the gag load until the boiler hydrostatic pressure is equal to 80% of the pressure to which the low set valve is adjusted.

3. Apply the gag load by turning the gag screw clockwise. If the gag on any valve has not been tightened sufficiently, the valve will leak.
If this occurs, the hydrostatic test pressure should be reduced until the valve becomes tight and then the gag should be tightened still further.

This procedure must be followed exactly since it is very difficult to stop the leak by additional gagging once it has started. Any attempt to pinch off the leakage through the valve without first lowering the hydrostatic pressure may result in damage to the valve seats.

4. After the hydrostatic test is completed, the gags should be removed when the hydrostatic pressure has been reduced to 85% to 90% of the low set valve.

Under no circumstances should the gags be left on valves with no hydrostatic pressure on the system.

IX. Presetting the Adjusting Rings

If the correct position of the adjusting rings (as measured in the disassembly procedure (see section X.) is not known, the valve adjusting rings may be positioned using the information in Table I.

The Lower Ring may be positioned by turning the lower adjusting ring up until

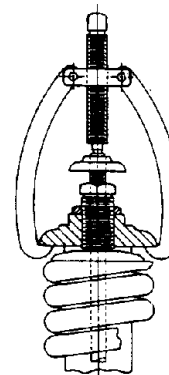

FIGURE 2



it contacts the disc. After choosing the appropriate orifice size, turn the adjusting ring down the corresponding number of notches listed in the "Lower Ring" column. Then, replace the adjusting ring pin. The adjusting ring must be free to move both directions, but not rotate.

The upper ring may be positioned by turning the upper adjusting ring down towards the nozzle bushing, until it reaches the extreme down position. Then after choosing the appropriate orifice size, turn the adjusting ring up the corresponding number of turns (360°) and notches, listed in the "Upper Ring" column. Then replace the adjusting ring pin. The adjusting ring must be free to move both directions, but not rotate.

The adjusting rings are now in a starting position for full lift steam testing. These adjusting ring settings will generally provide a blowdown greater than required by Section I of the ASME Code, and should be adjusted for the particular application.

Adjusting Ring Settings

NOTE: It is important to note that all adjustments of adjusting rings are DIVO initial adjustments only, and are not intended to be final adjustments. This final adjustment must be made on the operating system with conditions approximating those that will be realized under actual operating conditions.

1511 Safety Valve				
Orifice	Upper Ring No. of Notches	Lower Ring No. of Notches	Starting Position of Upper Ring From Extreme Down Position	Starting Position of Lower Ring From Touching Disc
H	30	24	Up 15 Notches	Down 2 to 6 Notches
J	36	30	Up 15 Notches	Down 2 to 7 Notches
K	45	32	Up 1 Turn & 15 Notches	Down 2 to 5 Notches
L	54	40	Up 1 Turn & 18 Notches	Down 3 to 13 Notches
M	45	36	Up 1 Turn & 22 Notches	Down 4 to 8 Notches
N	50	40	Up 1 Turn & 25 Notches	Down 5 to 12 Notches
P	50	42	Up 1 Turn & 25 Notches	Down 9 to 13 Notches
Q	60	48	Up 2 Turns & 30 Notches	Down 9 to 15 Notches
1811 Safety Valve				
Orifice	Upper Ring No. of Notches	Lower Ring No. of Notches	Starting Position of Upper Ring From Extreme Down Position	Starting Position of Lower Ring From Touching Disc
F	30	26	Up 3 Turns	Down 4 to 6 Notches
G	30	30	Up 3 Turns	Down 4 to 6 Notches
H	30	24	Up 3 Turns & 8 Notches	Down 5 to 8 Notches
J	36	30	Up 3 Turns & 15 Notches	Down 5 to 8 Notches
K	45	32	Up 5 Turns	Down 6 to 10 Notches
L	54	40	Up 5 Turns	Down 6 to 15 Notches
M	45	36	Up 5 Turns & 20 Notches	Down 6 to 15 Notches
N	50	40	Up 7 Turns	Down 6 to 15 Notches
P	50	42	Up 7 Turns	Down 8 to 15 Notches
Q	60	48	Up 9 Turns	Down 8 to 15 Notches

TABLE 1

X. Disassembly for Repair

Before removing the valve, be sure there is no steam pressure in the drum or header, then proceed as follows:

1. Remove lower ring pin.
2. Turn the lower ring upwards counting the number of notches moved until contact is made with the disc. Record this information for use during reassembly.

3. Remove the lever pin and lever.
4. Loosen the cap screw(s) and remove the cap.
5. Remove the release nut and lock nut or cotter pin.
6. Measure the distance from the top of the spindle to the top of the compression screw. Record this for use in reassembly to restore the correct spring compression.
7. Loosen the compression screw lock nut and remove the compression screw.
8. Remove the cap screws or stud nuts holding the yoke to the base and raise the yoke over the spindle. The spring for the 1511 will remain on the spindle. The 1811 spring will be removed with the yoke.
9. Remove the spring and spring washer assembly, record the spring number stamped in the spring. Mark the spring and washers top and bottom.
10. Lift the disc and spindle straight up to remove the disc from the valve body. Engage the drop through threads of the disc and unscrew it from the spindle.
11. Measure from the top of the combination guide and upper ring to the top of the bushing seat. Record this measurement for reassembly.
12. Remove the upper ring pin.
13. Remove the combination guide and upper ring by turning it upwards until the threads disengage.
14. Remove the lower adjusting ring. The valve is now completely disassembled.



XI. Inspection

A. General Information

Once the valve is disassembled, the appropriate parts can be inspected for damage and their suitability for reuse.

B. Specific Steps

1. Inspect the guide inside diameter for egging, and insure the inside surface is smooth. The threads on the outside must be in good condition to insure the adjusting ring/guide will adjust when the valve is hot. If serious, large scale galling or ridges corresponding to the grooves in the disc are present, the part should be replaced.
2. Disc - there are two different disc designs: The Flat Solid Disc (FSD) and the THERMOFLEX™ Disc (TFD). Each of these disc designs is available in either a low pressure (LP) or high pressure (HP) version.

Use the diagram below to determine which disc type is applicable.

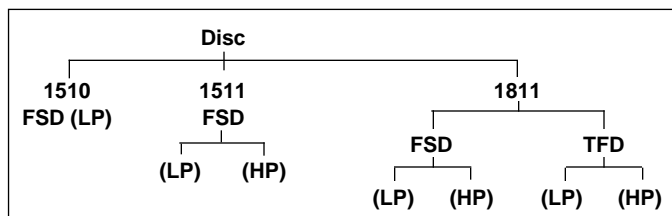
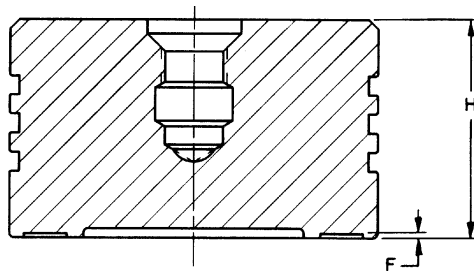

TABLE 2

XI.B. Continued

1510 and 1511 Flat Solid Disc Machining Dimensions



1511 HP FLAT SOLID
FIGURE 3

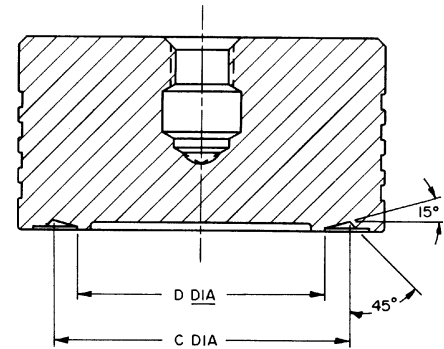

*1510 & 1511 LP FLAT SOLID
All 1511-124 psig & below
FIGURE 4

Note: All other dimensions identical to high pressure disc version for 1511.

Orifice	1511 HP H Dim.	1511 HP F Dim.
	(Min.) (Inches)	+ .005/- .000 (Inches)
H	1.140	.025
J	1.359	.025
K	1.453	.025
L	1.797	.025
M	1.859	.025
N	2.109	.025
P	2.739	.036
Q	3.547	.036

TABLE 3

When the "F" dimension is reduced (by machining or lapping the disc seat), to .015" for "H" through "N" orifices, or to .026" for "P" and "Q" orifices, restore the dimensions indicated in Table 3. The 1511 Flat Solid Disc (FSD) can be remachined until dimension "H" (Minimum) is reached.

Orifice	1511 LP C ± .005	1511 LP D Dia ± .002
	(Inches)	(Inches)
H	1.552	1.349
J	1.983	1.683
K	2.372	1.977
L	2.948	2.418
M	3.307	2.722
N	3.639	3.011
P	4.206	3.608
Q	5.795	4.682

TABLE 4

***Note:** Type 1510 has a Lift Restrictor inside the spring and is limited to 15 psig max. set pressure. Otherwise, it is identical to Type 1511.

XI.B. Continued

1811-HP & 1811-LP Flat Solid Disc Machining Dimensions

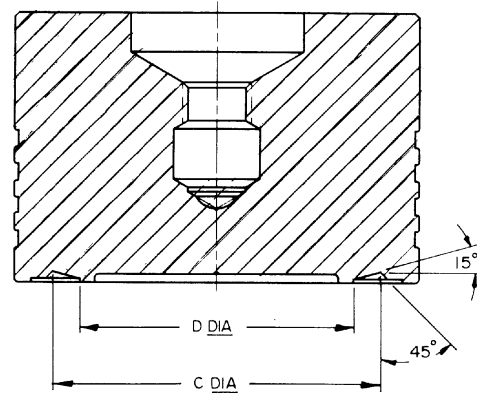
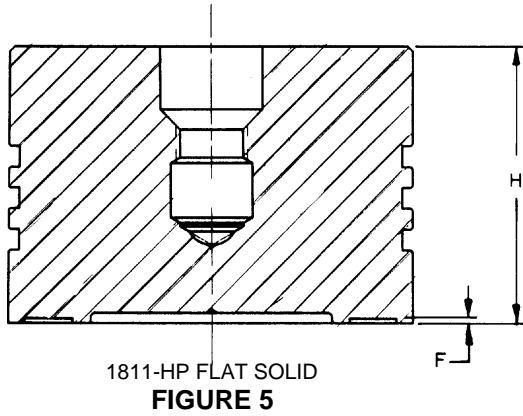

Note: All other dimensions identical to high pressure disc version for 1811 Flat Solid.

Orifice	1811-HP H Dim. (Min.) (Inches)	1811-HP F Dim. +.005 / -.000 (Inches)
F	1.173	.025
G	1.173	.025
H	1.454	.025
J	1.579	.025
K	1.860	.025
L	2.266	.025
M	2.360	.025
N	2.922	.025
P	3.312	.036
Q	3.922	.036

TABLE 5

Orifice	1811-LP C ±.005 (Inches)	1811-LP D Dia. ±.002 (Inches)
F	-	-
G	-	-
H	-	-
J	1.983	1.680
K	2.372	1.977
L	2.948	2.418
M	3.307	2.722
N	3.639	3.060
P	4.206	3.700
Q	5.795	4.800

TABLE 6

NOTE: When the “F” dimension is reduced (by machining or lapping the disc seat), to .015” for “F” through “N” orifices, or to .026” for the “P” and “Q” orifices, restore the dimensions indicated in Table 5. The 1811 Flat Solid Disc (FSD) can be remachined until dimension “H” (Minimum) is reached.

XI.B. Continued

1811-HP & LP THERMOFLEX™ Disc (TFD)

REPLACEMENT CRITERIA

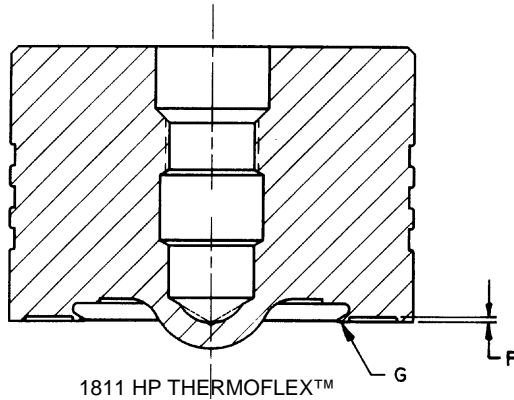

1811 HP THERMOFLEX™
FIGURE 7

REPLACEMENT CRITERIA

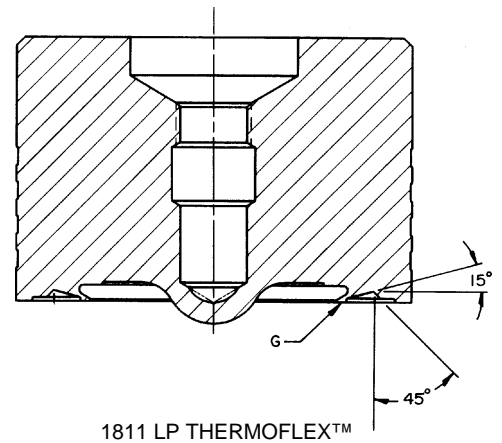

1811 LP THERMOFLEX™
FIGURE 8

Note: All other dimensions identical to high pressure disc version for 1811 THERMOFLEX™ Disc

1811-HP THERMOFLEX™ Disc Replacement Criteria

Orifice	F (MIN.) (Inches)
F	.020
G	.020
H	.020
J	.020
K	.020
L	.020
M	.020
N	.020
P	.030
Q	.030

TABLE 7

1811-LP THERMOFLEX™ Disc Replacement Criteria

Orifice	F (MIN.) (Inches)
F	.020
G	.020
H	.020
J	.020
K	.020
L	.020
M	.020
N	.020
P	.030
Q	.030

TABLE 8

The 1811-HP & LP THERMOFLEX™ Discs are designed for steam service, and are standard on all new 1811 Safety Valves. The THERMOFLEX™ Disc prevents most seat damage by maintaining a tight seal at higher operating pressures than the Flat Solid Disc. Inspect the disc seat for steam cuts, nicks, or other damage. If minor damage has occurred, the seat may be restored by lightly lapping seat area G, as indicated in Figures 7 & 8. **Do not machine THERMOFLEX™ Discs.** If dimension F is reduced to the minimum indicated in Table 7, the disc should be replaced. Other replacement criteria include thread damage, spindle bearing surface damage and severe galling. Egging caused by vibration and wear also require replacement to maintain “like new” valve performance.

XI.B. Continued

NOTE: Due to the thin seat lip, THERMOFLEX™ Discs can not be machined. Damage, if present, may be removed by lapping unit “F” (min.) is exceeded. The THERMOFLEX™ Disc requires replacement when the “F” (min.) dimension is exceeded.

If you find flexible seating configurations different from those shown in Figures 7 & 8, replacement with the current, improved design THERMOFLEX™ Disc is recommended.

3. Clearance between the disc and upper ring/guide:
Measure the I.D. of the guide and the O.D. of the disc; subtract to find the cold clearance.

The maximum clearance should not be greater than the value indicated in Table 5. Greater clearances can indicate wear and can generate alignment problems and cause the valve not to reseat properly.

Orifice Size	1511/1811 Flat Solid Disc Low Pressure Disc 1811 THERMOFLEX™ Disc Min./Max. (Inches)	1511/1811 Guide I.D. Min./Max. (Inches)	1511/1811 Disc/Guide Clearance Min./Max. (Inches)
F*	1.189/1.192	1.196/1.200	.004/.011
G*	1.521/1.524	1.532/1.536	.008/.015
H	1.905/1.908	1.915/1.919	.007/.014
J	2.445/2.448	2.455/2.459	.007/.014
K	2.926/2.929	2.935/2.939	.006/.013
L	3.638/3.641	3.648/3.652	.007/.014
M	4.079/4.082	4.089/4.093	.007/.014
N	4.483/4.486	4.498/4.502	.012/.019
P	5.448/5.451	5.459/5.465	.008/.017
Q	7.137/7.140	7.150/7.156	.010/.019

* Not available in the 1511 Safety Valve Series

TABLE 9

4. Adjusting rings:
If damage is present on the lower surface of the upper adjusting ring, or on the upper surfaces of the lower adjusting ring, the damaged part must be replaced. Thread damage may also be a cause for replacement, if it prevents adjustments when the valve is heated.
5. Bushing Seat:
Seat bushings are normally treated as part of the valve body and should be machined when necessary, inside the valve body. (See Seat Bushing Machining Instructions, section XII.B.) When the "E" dimensions are reduced by machining or lapping to a minimum given in Table 6, for 1511 Valves, or Table 7 for 1811 Valves, the valve seat bushing should be remachined to the given dimensions. **The bushing seat can be remachined in both the 1511 and the 1811 Safety Valves until the limiting dimensions are reached. See instructions concerning the "H" dimension for 1511 Valves in Table 6, and the "Z" dimension for the 1811 Valves in Table 11.** The bushing seat must be lapped to a mirror finish to determine if they are flat and free of nicks, cuts and scratches. (See section XII.C. for Lapping Instructions.)

XI.B. Continued

1511 Seat Bushing Machining Dimensions

Orifice	E Dim. (Min. Before Machining) (Inches)	E Dim. +.005 -.000 (After Machining) (Inches)	F Dim. +.005 -.000 (Inches)	G Dim. (Min.) (Inches)
H	.020	.025	.076	.937
J	.020	.025	.098	.937
K	.020	.025	.117	1.187
L	.020	.025	.146	1.375
M	.020	.025	.164	1.375
N	.020	.025	.179	1.500
P	.025	.036	.217	1.750
Q	.025	.036	.285	2.187

NOTE: The 1511 seat bushing is threaded into the valve base. It may be removed, but it is better to machine it in the valve base. If the seat bushing is removed, a high temperature thread sealant like Copaltite (National Engineering Products, Inc.) should be used to seal the seat bushing into the base.

When the "G" dimension is exceeded, remove and replace the seat bushing.

When the "E" dimension is reduced by lapping or machining the bushing seat to .020" for the "H" through "N" orifices, or .025" for the "P" and "Q" orifices, remachine the seat bushing to maintain the existing seat diameters, and restore the dimensions indicated.

The 1511 Valve seat bushing can be reworked until the "G" dimension reaches the minimum listed in column "G".

TABLE 10

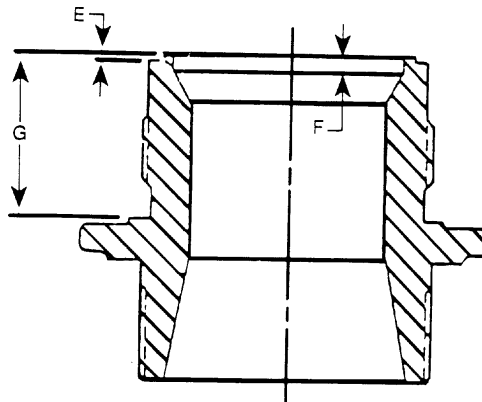

FIGURE 9

XI.B. Continued**1811 Base and Bushing Assembly Machining Dimensions**

Orifice	Z Dim. (Max.) (Inches)	E Dim. (Min. Before Machining) (Inches)	E Dim. +.005 -.000 (After Machining) (Inches)	F Dim. +.005 -.000 (Inches)
F	2.083	.015	.025	.110
G	2.083	.015	.025	.086
H	2.208	.015	.025	.100
J	2.187	.015	.025	.123
K	2.645	.015	.025	.142
L	3.083	.015	.025	.171
M	3.458	.015	.025	.189
N	3.958	.015	.025	.204
P	4.458	.025	.036	.242
Q	5.333	.025	.036	.310

NOTE: The "Z" dimension is the distance from the bushing seating surface to the machined surface of the base head flange as shown in Figure 10. **Do not remachine base head flange surface.**

When the "E" dimension is reduced by lapping or machining the nozzle seat to .015" for the "F" through "N" orifices, or .025" for the "P" and "Q" orifices, remachine the seat bushing to maintain the existing seat diameters, and restore the dimensions indicated.

Allowances have been made to remachine the bushing seat. The amount of rework is controlled by dimension "Z". The 1811 seat bushing is welded into the base and must be replaced when the "Z" dimension is exceeded.

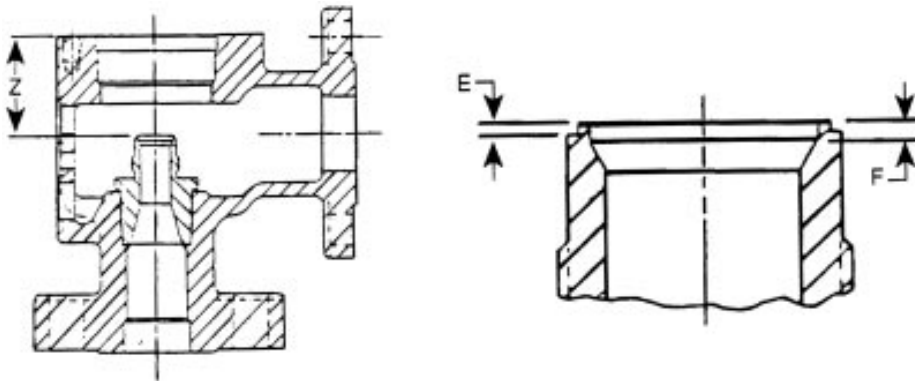
TABLE 11**FIGURE 10**

XII. Maintenance Instructions

A. General Information

The 1511 and 1811 Safety Valves are easily maintained. Normal maintenance usually involves:

- Disassembly
- Cleaning
- Component Inspection
- Lapping the Seats
- Reassembly
- Setting, Testing and Resealing the Valve

Occasionally, remachining the seat bushing may be necessary to extend the service life of the valve. In any case, keep all parts for each valve together or marked to insure that they are replaced in the same valve.

The following tools are recommended for normal maintenance and following remachining:

1. Flat lapping plate, (for resurfacing ring laps) - Part Number 0439004*
2. Grinding Compounds*
3. High temperature thread lubricant* - (Fel-Pro, Nickel Ease, or equivalent)
4. Two (2) ring laps per valve size and type*

***NOTE:** See maintenance Tools and Supplies in section XVII.

All of the above tools can be purchased from DIVO, with prices in effect at the time of delivery. It may not be necessary to use all of the ring laps at any one time, but having a sufficient supply on hand will save reconditioning time during a boiler outage. After the boiler is back in operation, the ring laps can be reconditioned on the flat lapping plate. Lapping compound, when used with ring laps, wears off the seat surface on the disc or seat bushing, but it also wears off the flat surface of the ring lap. A lap should not be used on more than one valve without being reconditioned.

Lapping procedure for reconditioning the seating surfaces of the disc and seat bushing is outlined in section XII.C.

XII. Continued

B. Machining

After the parts have been determined to be reusable, proper machining technique must be employed in reestablishing disc and seat bushing dimensions.

On both the 1511 and 1811 valves, the seat bushing should be machined in the valve base to insure proper parts alignment. When chucking the valve base or disc into a lathe, alignment must be within .001 total indicator runout at the points indicated on the following drawings as "A", "B", and "C".

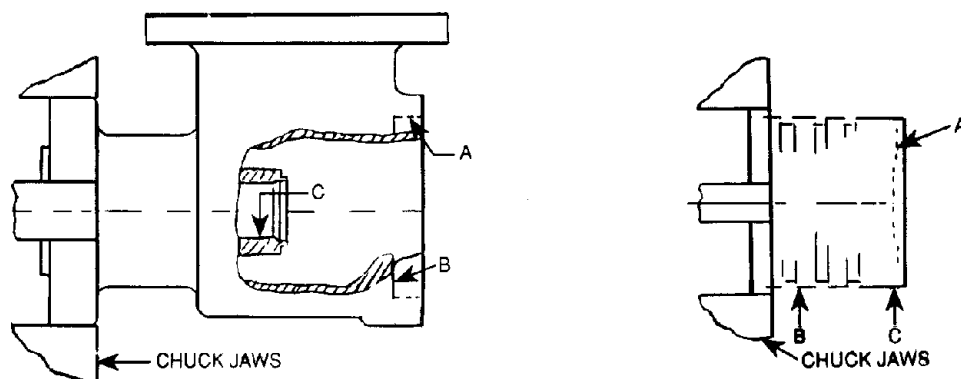

FIGURE 11

NOTE: THERMOFLEX™ Discs *can not be machined* without damaging the lip thickness.

See section XII.B for rework dimensions for the seat bushing and Flat Solid Discs.

C. Lapping Procedures

1. General:

While the finer points of lapping may be considered a mechanical art, it is possible for the average mechanic to produce satisfactory results with some practice. No effort has been made in this manual to establish an exact procedure to cover each and every case because different people can achieve the same results using their own techniques.

The following materials will be of assistance when lapping bushing and/or disc seats:

- a. Two ring laps per valve
- b. 1-A Clover Grinding Compound
- c. 1000 grit Kwik-Ak-Shun Grinding Compound
- d. Lint free wipers for cleaning

2. Lapping the seat bushing or Disc Seat:

Before lapping the seat bushing and disc, use a fine grade sandpaper to lightly break the inner edge and outer edge of the bushing and disc seats.

XII.C. Continued

This chamfer should not exceed .002 inches (.05mm). If the seating surfaces require extensive lapping or reconditioning, machining should be considered prior to lapping. See Inspection Section XI.B. for criteria. Cover one flat surface of a ring lap with a thin coating of Clover 1-A Grinding Compound and gently set the lap on the seat surface. ***Thick coatings tend to round off edges of the seat.*** Lap using a slight oscillating motion in various directions. Control the motion of the lap to prevent the inside edge or outside edge of the lap from running off the seating surface, as this may cause the seat to become scratched or uneven.

3. Polishing or Finish Lapping:

Wipe off all used compound from the bushing or disc. Then use a flat, reconditioned ring lap, and light coating of Kwik-Ak-Shun 1000 Grit Grinding Compound to lap the seat. After lapping the seat for some time, wipe off all grinding compound from the ring lap (do not wipe off the compound on the bushing or disc seat). Using only the compound remaining on the seat, and the clean ring lap, continue to lap until it becomes difficult to move the ring lap on the seat. Again, wipe off the grinding compound from the ring lap only, and using the remaining compound on the seat continue to lap. The seating surface will become mirror like as the grinding compound is further broken down. Inspect the seat for cuts and scratches, repeat procedures as necessary to eliminate damage.

Once the seat surface is flat, clear and mirror-like, wipe all traces of grinding compound from the part and begin reconditioning the other seat. ***Do not place the disc in a vice to accomplish lapping procedures, as damage can occur to disc surfaces and distortion to the seating surface.***

D. Reconditioning a Ring Lap

To recondition a ring lap, use Clover 1-A Compound on the lapping plate, and move the ring lap in a "figure 8" motion as shown in Figure 12. Continue lapping until all indications of wear (on both sides), are removed from the ring lap and a uniform grey surface is achieved. The ring lap is ready to use on the next valve. A lap that is flat within one light band is considered satisfactory for use. Information on the monochromatic light and optical flat is available upon request from the DIVO Field Service Department.

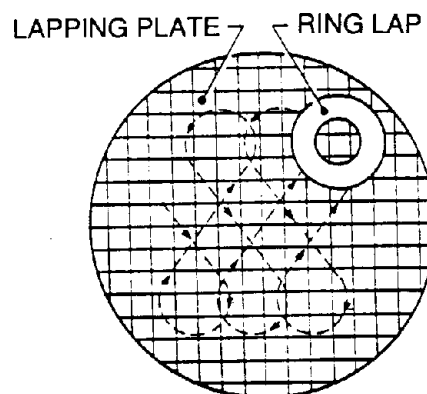

FIGURE 12

XII. Continued

E. Spindle Runout

It is important that the spindle be kept very straight in order to transmit the spring force to the disc without lateral binding. Overgagging is one of the common causes of bent spindles. A method to check the essential working surfaces of the spindle is illustrated in Figure 13 below.

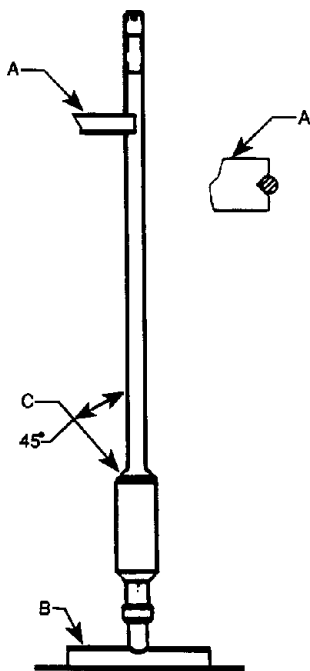

FIGURE 13

Using a spindle check stand (see Figure 13 as a reference), place the ball end of the spindle into a depression at the base "B" of the stand. Lean the upper portion of the spindle against the "V" block. It should be touching the spindle just below the threads on the upper portion of the spindle. Using a machinist's indicator on a 45° angle at spindle shoulder "C", rotate the spindle and read the Total Indicator Run out on the indicator. If the TIR is less than .007 inches, the spindle may be returned to service. If the TIR is greater than .007 inches, straighten the spindle using "V" blocks and a hydraulic press until the TIR is less than .007 inches.

Other parts of the spindle not used as working surfaces may run out considerably more than .007 inches (.177mm), but this should not be regarded as unacceptable. Although the upper thread end is not a working surface, excessive bending in this area could effect the accuracy of the DIVO Hydroset device, and/or the DIVO Electronic Valve Tester, if either of these devices is used to verify valve set pressure.

XII. Continued

F. Spring and Spring Washers

Spring wire that is irregularly spaced, or the ends are not parallel, are sufficient causes for replacement. The spring washers are machined to fit the ends of the spring - there should be no more than a .030 inches clearance between the spring and the spring washer. If a spring is badly damaged by corrosion (flaking, pitting, or reduction in wire diameter), replace the spring with the proper spring. If the spring is unable to be identified contact the DIVO Field Service Department at (318) 640-6055.

G. Lift Restrictor

Both Types 1510 & 1511 with set pressures of 15 psig and below will have a Lift Restrictor installed on the spindle stem, located inside the spring. Measure to verify minimum length for the appropriate orifice. See Table 12. If under the minimum length, replace the Lift Restrictor.

**1510 & 1511
LIFT RESTRICTOR**

Orifice	Minimum Length (Inches)
H	2 1/4"
J	2 1/4"
K	3 1/2"
L	3 1/2"
M	3 1/2"
N	3 1/2"
P	3 15/16"
Q	5"

TABLE 12

XIII. Reassembly

During reassembly, three items are of extreme importance. They are:

- 1) Alignment
- 2) Cleanliness
- 3) Lubrication

To achieve the correct alignment, the bearing surfaces of the compression screw/upper spring washer, spindle/lower spring washer and spindle to disc pocket should each be ground together to attain a perfect match. This is done by applying a lapping and grinding compound of about 500 grit on one of the surfaces and rubbing them together until a smooth unbroken contact point is established on both surfaces.

XIII. Continued

All bearing surfaces and threaded areas must be lubricated using a high quality high temperature lubricant. At the factory, nickel-ease is used and is recommended. For environments where corrosion is a problem, contact the factory field service department for suggestions on special coating or plating procedures which will protect the parts.



1. Thread the lower ring onto the seat bushing and turn it down until it is below the seating surface. (This allows the disc to rest on the bushing without interference from the ring).
2. Thread the upper ring/guide into the valve body reestablishing its original relationship to the bushing, as measured in Disassembly, Step 2. Insert the upper adjusting ring pin into the valve and tighten. The ring should now be able to rock back and forth but not turn. If position is not known, refer to Section IX.
3. After inspecting both the disc and bushing seat for cleanliness, thread the spindle into the disc and insert the disc gently into the valve until it rests on the bushing.
4. On the 1511, place the spring and spring washers onto the spindle. On the 1811, place the spring and spring washer into the yoke.
5. Place the yoke or yoke and spring assembly over the spindle and replace the cap screws or nuts. Care must be taken to tighten the yoke down evenly to prevent distortion and misalignment.
6. Thread the compression screw into the yoke, reestablish the original relationship between compression screw and spindle, as measured in disassembly, Step 6. Then tighten the compression screw lock nut.
7. Raise the lower ring until it contacts the disc then lower it the number of notches needed to reestablish its original relationship to the disc. Thread the lower adjusting ring pin into the body and tighten. The ring should be free to rock back and forth but not turn. If position is not known, refer to Section IX.
8. Thread the release nut onto the spindle and replace the cap, lever and lever pin. Adjust the release nut so there is from 1/8" to 1/16" clearance between the release nut and lever. Remove the lever pin, lever and cap, replace the lock nut or cotter pin, and tighten it against the release nut. Replace the cap, lever, lever pin and cotter pin and tighten the set screw. The valve is now ready for setting and testing.

XIV. Steam Testing Procedures

1. Remove the caps on all valves to be set on the steam drum and main steam line, or other pressure vessel.
2. Install a "verified calibrated" pressure gauge on the drum near the valves being set. When the main steam line valves are to be set, install the calibrated gauge to read line pressure upstream of the valves to be tested.
3. After the pressure in the boiler has increased to 80% of the operating pressure, install gags on all valves except the high set valve. Gags should be installed hand tight (no wrenches or mechanical force).
4. Examine the nameplate on the high set valve. The symbol that is present on the nameplate will indicate the proper standard of operation, as described in table 8.

During reassembly, the adjusting rings and compression screw should be reset as they were prior to disassembly. (If the correct adjusting rings positions are not known, the adjusting rings should be preset according to instructions in section IX.) Before attempting to make ring adjustments on a valve under pressure, ***gag the valve.***

XIV. Continued

ASME Boiler and Pressure Vessel Code Section and Symbol	Set Pressure Tolerance (The valve must "POP" open within the range indicated below.)	Blowdown Requirements
<div style="text-align: center;">  <p>CODE SYMBOL STAMP ASME Section I</p> </div>	<p>If valve set pressure is less than or equal to 70 psig ± 2 psig</p> <p>If valve set pressure is 71 psig up to and including 300 psig $\pm 3\%$ of set pressure</p> <p>If valve set pressure is 301 psig up to and including 1000 psig ± 10 psig</p> <p>If valve set pressure is 1001 or greater $\pm 1\%$ of set pressure</p>	<p>After opening, the valve must reclose within a range of 98% to 96%, however, if the valve set pressure is 100 psig or less the valve must reclose within a range of 2 to 4 psig below set pressure.</p>
<div style="text-align: center;">  <p>CODE SYMBOL STAMP ASME Section VIII</p> </div>	<p>If valve set pressure is less than or equal to 70 psig ± 2 psig</p> <p>If valve set pressure is 71 psig or greater $\pm 3\%$ of set pressure</p>	<p>After opening the valve must reclose before the system pressure returns to normal operating pressure.</p>

DRESSER RECOMMENDS THAT THE MAXIMUM OPERATING PRESSURE NEVER EXCEEDS 94% OF THE SET PRESSURE OF ANY 1510, 1511, OR 1811 SERIES SAFETY VALVE.

TABLE 13

5. When presetting is complete, remove the gag and replace the cap and lifting lever assembly. Attach a rope to the lever and stand by to hold the valve open if necessary. Now the valve is ready to test.
6. Increase the boiler pressure at a rate not to exceed 2 psi per second. Note and record the pressure indicated on the pressure guage when the valve pops open. After the valve pops open, reduce the fire in the boiler and lower the pressure until the valve closes. Note and record the pressure when the valve closes.
7. Determine if the valve popping point and reseating point comply with the ASME requirements.
 - a. If the valve operation meets the appropriate standard, raise the pressure in the boiler and conduct two more verification test.
 - b. If in raising the boiler pressure, the valve does not pop open within 3% overpressure (for ASME Section I valves), or 10% overpressure (for ASME Section VIII valves), **reduce the fire in the boiler and pull the rope to open the valve.** Release the rope and allow the valve to close when the boiler pressure returns to operating level. Allow the boiler to reduce to approximately 85% of the set pressure. Remove the cap and lifting lever assembly from the valve, and turn the compression screw lock nut counter-clockwise (as viewed from the top of the valve) until it moves freely. Reduce the compression in the spring by turning the

XIV. Continued

adjusting screw counter clockwise one turn (as viewed from the top of the valve). Replace the cap and lifting lever and retest the valve. Continue repeating this procedure until the valve opens at, or below, the set pressure recorded on the nameplate.

- c. If the valve opens at a pressure below the recorded set pressure, allow the valve to close and the boiler pressure to reduce to 85% of set pressure. Increase the compression on the spring by turning the compression screw clockwise 1/6th of a turn. Tighten the adjusting screw lock nut and replace the cap and lifting lever assembly. Retest the valve as described in Step 6. If the valve continues to open below the required set pressure, calculate how many turns to move the adjusting screw to cause the valve to open at the correct set pressure. Adjust as necessary.
- d. If the valve opens and closes rapidly, (called "chattering") hold the valve open to prevent damage to the valve. **Reduce the fire in the boiler** and allow the boiler pressure to reduce to approximately 85% of the set pressure. Gag the valve, and reset the adjusting rings according to presetting instructions, (see section IX).
- e. If the valve indicates simmer at a pressure greater than 1% of the set pressure of the valve, allow the valve to reseat and the boiler pressure to reduce to 85% of set pressure. **Gag the valve** to prevent accidental lifting while making adjustments. Remove the lower adjusting ring pin and raise the lower adjusting ring. As viewed through the ring pin hole, move the adjusting ring from left to right one or two notches. Remove the gag, retest and note when simmer occurs and repeat as necessary.

NOTE: The lower adjusting ring should be adjusted to the notch that provides a minimum of simmer and does not interfere with the blowdown of the valve.

- f. If the valve "pops" open then drops out of lift, like it was going to close, but remains open at a very low lift, this is called a "hang up" and indicates that the position of the lower adjusting ring is interfering with the blowdown of the valve. To correct a hang up, **gag the valve**, remove the lower ring pin and lower the adjusting ring one notch (as viewed through the ring pin hole, move the adjusting ring from the right to the left to lower the adjusting ring). Remove the gag, retest and note the reseating pressure of the valve it should close sharply at a higher pressure.
- g. If the valve closes sharply but the reseating pressure is too low in comparison to the standard in Table 13, blowdown is excessive. **Gag the valve**, remove the upper ring pin, raise the upper adjusting ring 10 notches, replace the ring pin, remove the gag and retest the valve. If the reseating pressure has not risen enough to meet the blowdown standard, repeat the procedure until the blowdown standard is achieved.

NOTE: It may be possible that in raising the upper adjusting ring to reduce the blowdown, the valve may develop a hang up, correct it as described in step f. above, and then continue if necessary to reduce the blowdown.

- h. If the blowdown is less than the standard required, the reseating pressure can be lowered by gagging the valve, removing the upper ring pin and lowering the upper adjusting ring 10 notches (as viewed through the ring pin hole, move the adjusting ring from the right to the left.) Remove the gag, replace the adjusting ring pin and retest the valve. If

XIV. Continued

the reseating pressure is not reduced enough to meet the standard, repeat this procedure until the standard is achieved. The upper adjusting ring should be positioned to provide no more blowdown than that indicated in the ASME Code Standard.

8. Once the valve has tested in compliance with the appropriate standard, conduct two more verification tests. All external adjustments should be sealed after completing final setting.
9. Proceed to the next valve to be tested.

XV. Electronic Valve Testing (EVT)

Periodic tests may be required for verification of valve set pressure. The DIVO EVT provides for this capability. However, set pressure is the only factor which can be verified. Valves should be initially set using full system pressure (as outlined in section XIV. of this manual). The EVT may be used for subsequent checks of set pressure.

Accuracy of results obtained by the use of this device depends on several factors. First, friction must be reduced as a source of error, so that, for a given pressure, the EVT repeatedly produces exactly the same lifting force. Second, gauge calibration and vibration, and the effective seating area between valves of the same size and type, will also affect accuracy. With well calibrated gauges and valve seats in good condition, accuracy on the order of 1% of set pressure may be expected. Upon request, DIVO will provide pertinent written material concerning the EVT. This material specifies all required information necessary to insure proper usage of this device.

XVI. Trouble Shooting The 1511 and 1811 Valves

Problem	Possible Cause	Corrective Action
Valve does not go into full lift.	<ul style="list-style-type: none"> A. Upper ring positioned too high B. Foreign material trapped between disc holder & guide 	<ul style="list-style-type: none"> A. Lower upper adjusting ring B. Disassemble valve and correct any abnormality. Inspect system for cleanliness.
Failure to open at set pressure	<ul style="list-style-type: none"> A. Improper compression screw adjustment 	<ul style="list-style-type: none"> A. Adjust set pressure
Simmer	<ul style="list-style-type: none"> A. Lower ring positioned too low. B. Steam line vibrations 	<ul style="list-style-type: none"> A. Raise lower adjusting ring B. Investigate and correct cause
Valve Leaking and/or exhibits erratic popping actions.	<ul style="list-style-type: none"> A. Damaged seat B. Part misalignment C. Operating too close to set pressure D. Discharge stack binding on valve outlet 	<ul style="list-style-type: none"> A. Disassemble valve, lap seating surfaces, replace disc if required. B. Disassemble valve, inspect contact area of disc and seat bushing, lower spring washer or spindle, compression screw, spindle straightness, etc. C. Lower operating pressure and/or retrofit to THERMOFLEX™ Disc design. D. Correct source of binding
Hang-up, or valve does not close completely.	<ul style="list-style-type: none"> A. Lower ring positioned too high B. Foreign material C. Improper disc/guide clearance 	<ul style="list-style-type: none"> A. Move lower ring to the left one notch per adjustment and test. Repeat until problem is eliminated. B. Disassemble valve and correct any abnormal condition. Inspect system for cleanliness. C. Verify proper clearance
Excessive blowdown	<ul style="list-style-type: none"> A. Upper ring positioned too low. B. Built up back pressure excessive 	<ul style="list-style-type: none"> A. Raise upper adjusting ring B. Decrease exhaust pressure by increasing discharge stack area.
Chatter or short blowdown	<ul style="list-style-type: none"> A. Upper ring positioned too high B. Excessive inlet piping pressure drop C. Valve size improper for application 	<ul style="list-style-type: none"> A. Lower upper adjusting ring B. Reduce inlet pressure drop to less than one-half of required valve blowdown by redesigning inlet piping. C. Verify valve sizing

XVII. Maintenance Tools and Supplies

Ring Laps

VALVE ORIFICE	PART NO.	VALVE ORIFICE	PART NO.
F	1672805	M	1672810
G	1672805	N	1672811
H	1672806	P	1672811
J	1672807	Q	1672812
K	1672808		
L	1672809		

Lapping Compounds

BRAND	GRADE	GRIT	LAPPING FUNCTION	SIZE CONTAINER	PART NO.
1. Clover	1A	320	General	4 oz.	1993
2. Clover	3A	500	Finishing	4 oz.	1994
3. Kwik-AK - Shun	--	1000	Polishing	1 lb. 2 oz.	19911 19912

Lubricants

BRAND	APPLICATION POINTS	SIZE CONTAINER	PART NO.
Nickel-Ease	All threaded connections Spindle Tip-Ball End Spindle-Washer Bearing Radius Compression Screw-Bearing End	2 oz.	VA437

TABLE 14

XVIII. Service Parts Inventory Philosophy

The basic objectives in formulating a replacement parts plan are:

- PROMPT AVAILABILITY
- MINIMUM DOWNTIME
- SENSIBLE COST
- SOURCE CONTROL

Guidelines for establishing meaningful inventory levels:

Parts Classification

PART CLASSIFICATION	REPLACEMENT FREQUENCY	PREDICTED AVAILABILITY
CLASS I	MOST FREQUENT	70%
CLASS II	LESS FREQUENT BUT CRITICAL	85%
CLASS III	SELDOM REPLACED	95%
CLASS IV	HARDWARE	99%
CLASS V	PRACTICALLY NEVER REPLACED	100%

Consult the Recommended Spare Parts list (see Section XIX of this manual) to define the parts to be included in the inventory plan.

Select parts and specify quantities.

XIX. Recommended Spare Parts

A. 1511 Safety Valve

Class	Part Name	Ratio Parts/Valves (Minimum)	Ratio Parts/Valves (Maximum)	Predicted Availability
I	1. Disc	1/3	1/1	70%
	2. Adj. Ring Pin (Upper)	1/3	1/1	
	3. Adj. Ring Pin (Lower)	1/3	1/1	
II	4. Adj. Ring (Upper)	1/5	1/3	85%
	5. Adj. Ring (Lower)	1/5	1/3	
	6. Spindle	1/5	1/3	
III	7. Spring	1/5	1/3	95%
	8. Spring Washers (2)	1 Set/5	1 Set/3	
	9. Compression Screw	1/5	1/3	
	10. Seat Bushing	1/5	1/3	
IV	11. Compression Screw Nut	1/5	1/3	99%
	12. Lock Nut	1/5	1/3	
	13. Release Nut	1/5	1/3	
	14. Cap & Lever Assembly	1/5	1/3	

TABLE 15

B. 1811 Safety Valve

Class	Part Name	Ratio Parts/Valves (Minimum)	Ratio Parts/Valves (Maximum)	Predicted Availability
I	1. FSD Disc	1/3	1/1	70%
	1a. TFD Disc	1/3	1/1	
	2. Adj. Ring Pin (Upper)	1/3	1/1	
	3. Adj. Ring Pin (Lower)	1/3	1/1	
II	4. Adj. Ring (Upper)	1/5	1/3	85%
	5. Adj. Ring (Lower)	1/5	1/3	
	6. FSD Spindle	1/5	1/3	
	6a. TFD Spindle	1/5	1/3	
III.	7. Spring	1/5	1/3	95%
	8. Spring Washers (2)	1 Set/5	1 Set/3	
	9. Compression Screw	1/5	1/3	
IV	10. Compression Screw Nut	1/5	1/3	99%
	11. Lock Nut	1/5	1/3	
	12. Release Nut	1/5	1/3	
	13. Cap & Lever Assembly	1/5	1/3	

NOTE: The 1811 Seat Bushing is welded into the body. It is not replaceable in the field. Return to Factory for replacement, or order new Body-Bushing Assembly.

DESIGN CODE KEY:

FSD - Flat Solid Design is designated by a "-20" or "-21" in the valve code on the nameplate (example: 1 1/4" 1811 FA-0-3X1-20).

TFD - THERMOFLEX™ Disc Design is designated by a "-22" or "-23" in the valve code on the nameplate (example: 1 1/4" 1811 FA-0-3X1-22). Will be furnished in all 1811 Valves shipped after January 1984, unless otherwise specified by customer.

TABLE 16

XX. Retrofit - THERMOFLEX™ Disc

Retrofit Kits have been developed for converting older 1811 Series Valves from solid disc to THERMOFLEX™ Disc design. The Kits include a new spindle and disc. The THERMOFLEX™ Disc design provides a significant improvement in seating tightness. The Retrofit can be installed during a routine overhaul at very little additional cost.

A retrofit tag should be added beneath the original nameplate to reflect this design change.

NOTE: Older 1811 Safety Valves have bottom spring washers which may require changing when retrofitting.

XXI. Identification and Ordering Essentials

Identification and Ordering Essentials

When ordering service parts, please furnish the following information to ensure receiving the correct replacement parts:

Identify valve by the following nameplate data:

1. Size
 2. Type
 3. Temperature Class
 4. Serial Number
- Example: 1 1/2" 1811JA-0-6X1-22
BY-23098

Specify parts required by:

1. Part Name (See illustration at front of manual).
2. Part Number (if known)
3. Quantity

Contact Parts Marketing: 1-318-640-2250

In addition, the serial number is stamped on the top edge of the outlet flange. Be sure to include the one or two letters preceding the figures in the serial number. A typical valve nameplate is shown in Figure 14.

		CONSOLIDATED				NB
		CERTIFIED BY <small>ALEXANDRIA, LOUISIANA U.S.A.</small>				
TYPE	1811JA-0-6X1-22					
	SIZE	1 1/2	SERIAL NO.	BY-23098		
	SET PRESS.	600	PSI LIFT	.320	IN.	
CAP.	36763	LBS/HR. AT	SAT.	•F		
B/M	9403401	DATE	3-93			

FIGURE 14

XXII. Manufacturer's Field Service & Repair Program

A. Factory Setting vs. Field Setting

Every CONSOLIDATED Safety Valve is set and adjusted on steam before shipment from the factory. Ring adjustments are made at the factory. However, it must be recognized that actual field operating conditions may vary considerably from factory test conditions.

Conditions beyond the manufacturer's control that affect Safety Valve operation include:

- Improper header nozzle design
- Quality of media being discharged
- Discharge piping stresses and back pressure
- Ambient temperature
- Shipping or storage damage
- Improper gagging
- Damage due to foreign material in the steam

Final Safety Valve adjustments made on the actual installation are the best means of ensuring that the valves perform in compliance with the ASME Boiler Code and/or other applicable code requirements.

B. Field Service

Utilities and Process Industries expect and demand service at a moment's notice. CONSOLIDATED Field Service can be depended upon for prompt response, even in extreme off-hour emergency situations.

DIVO maintains the largest and most competent field service staff in the industry. Service Engineers are located at strategic points throughout the United States to respond to customer's requirements for service. Each Service Engineer is factory trained and long experienced in servicing Safety Valves. DIVO Service Engineers restore disc and seat bushing critical dimensions which affect valve performance, and are capable of modernizing valves in the field.

It is highly recommended that the professional talents of a DIVO Field Service Engineer be employed to make final field adjustments during the initial setting of all CONSOLIDATED Safety Valves.

All Field Service Engineers' activities are coordinated from the Alexandria, Louisiana, Field Service Office. Upon receipt of a purchase order number authorizing the trip, the engineer is dispatched.

Contact: Field Service Department, Field Service Supervisor at (318) 640-6055.

C. Factory Repair Facilities

The factory at Alexandria, Louisiana maintains a Consolidated Repair Center. The repair department, in conjunction with the manufacturing facilities, is equipped to perform specialized repairs and product modifications, e.g. bushing replacements, hydroset calibrations, electromatic relief valve repairs, etc.

Contact: Valve Repair Department at (318) 640-6058.

XXIII. Safety Valve Maintenance Training

Rising costs of maintenance and repair in the Utility and Process Industries indicate the need for trained maintenance personnel. Dresser Industrial Valve Operation conducts service seminars that can help your maintenance and engineering personnel to reduce these costs.

Seminars, conducted either at your site, or at our Alexandria, Louisiana manufacturing plant, provide participants with an introduction to the basics of preventative maintenance. These seminars help to minimize downtime, reduce unplanned repairs and increase valve safety. While they do not make "instant" experts, they do provide the participants with "Hands On" experience with Consolidated Valves. The seminar also includes valve terminology and nomenclature, component inspection, trouble shooting, setting and testing, with emphasis on the ASME Boiler and Pressure Vessel Code.

For further information, **Please contact the Product Training Manager by fax at (318) 640-6041, or telephone (318) 640-6054.**

XXIV. Genuine Dresser Parts

The next time replacement parts are needed, keep these points in mind:

- DIVO designed the parts
- DIVO guarantees the parts
- CONSOLIDATED valve products have been in use since 1879
- DIVO has worldwide service
- DIVO has fast response availability for parts

Worldwide Service Locations

Dresser Industries, Inc.
Industrial Valve Operations
P.O. Box 1430
Alexandria, LA 71309-1430
Telephone: 318/640-2250

Masoneilan North America
Operations
Dresser Canada, Inc.
5010 North Service Road
Burlington, Ontario
L7L 5R5, Canada
Telephone: 905/335-3529

EUROPE

Dresser Europe, S.A.
Industrial Valve Operations
Badenerstrasse 156
P.O. Box 369
CH-8021 Zurich, Switzerland
Telephone: (011-411) 241-0533

Dresser UK LTD.
Industrial Valve Operations
Trevithick Works
Gillibrands Estate
Skelmersdale, Lancashire
WN8 9TU England
Telephone: (011-44) 695-24234

Masoneilan Division
Dresser U.K., LTD.
Controls House
Riverside Way
Uxbridge, Middlesex
UB8 2YF England
Telephone: (011-44) 895-258161

VENEZUELA

Riese & CIA, S.A.
Apartado 372
Caracas, Venezuela
Telephone: (011-582) 541-1311

JAPAN

Dresser Japan, LTD.
Industrial Valve Operations
Room 405, Maersk Building
18, Nihon-Odori,
Naka-Ku Yokohama 231
Japan
Telephone: (011-81) 45-651-5601

SAUDI ARABIA

Dresser Al Rushaid Valve &
Instrument Co., LTD.
P.O. Box 10145
Jubail Industrial City 31961
Saudi Arabia
Telephone: (011-966) 3-341-0278

SOUTH AFRICA

Dresser Limited Valve &
Controls Division
P.O. Box 2234
16 Edendale Road
Eastleigh, Edenvale 1610
South Africa
Telephone: (011-27) 11-452-1550/1-7

Service Department



THE DRESSER FIELD SERVICE ORGANIZATION IS UNEQUALED.

For prompt field service, please call
 Dresser Industrial Valve Operations Service Department, Alexandria, Louisiana.
 Normal Working Hours - (318) 640-6055
 After Hours, Weekends, Holidays - (318) 640-2250

Location of Service Engineers	
ALABAMA, Huntsville	1
FLORIDA, Jacksonville	2
GEORGIA, Cartersville	3
ILLINOIS, Chicago	4
INDIANA, Crawfordsville	5
KENTUCKY, Maysville	6
LOUISIANA, Alexandria	7
LOUISIANA, New Orleans	8
NORTH CAROLINA, Winston-Salem	9
OKLAHOMA, Tulsa	10
PENNSYLVANIA, Philadelphia	11
SOUTH CAROLINA, Charleston	12
TEXAS, Dallas	13
TEXAS, Houston	14
VIRGINIA, Richmond	15

Sales Office Locations

UNITED STATES

Dresser Industries, Inc., Industrial Valve Operation
La. Highway 3225 at U.S. Hwy. 167 North, P.O.Box 1430, Alexandria, Louisiana 71309-1430
Telephone (*) 1-318-640-2250, Telex 586423, Fax (*) 1-318-640-6222

Eastern Region
85 Bodwell Street, Avon, Massachusetts 02322, Telephone: (*) 1-508-941-5407, Fax: (*) 1-508-427-8959

Northern Region
3201 North Wolf Road, Franklin Park, Illinois 60131, Telephone (*) 1-708-451-3913, Fax (*) 1-708-451-3997

Southern Region
15112 Morales Road (77032), P.O. Box 60078, Houston, Texas 77205-0078
Telephone (*) 1-713-986-6600, Fax (*) 1-713-986-6608

Western Region
1040 South Vail Avenue, Montebello, California 90640, Telephone (*) 1-213-723-9351, Fax (*) 1-213-721-9113

Latin American Region
10556 N.W. 26th Street, Suite D-201, Miami, Florida 33172, Telephone (*) 1-305-470-2766, Fax (*) 1-305-470-2743

CANADA

Dresser Canada, Inc., Valve & Controls Division
5010 North Service Road, Burlington, Ontario, L7L 5R5 Canada
Telephone (*) 1-905-335-3529, Fax (*) 1-905-336-7628

Dresser Canada, Inc., Valve & Controls Division
3530 78th Avenue, Edmonton, Alberta, Canada, T6B 2X9, Telephone (*) 403-465-7882, Fax (*) 403-468-0934

CHINA

Dresser Valve & Controls China
Room 1907, Capital Mansion, Xi Yuan Nan Road, Chao Yang District, Beijing, China 10004
Telephone (*) 86-10-466-7189, Fax (*) 86-10-466-7190

JAPAN

Dresser Japan, Ltd., Industrial Valve Operation
11-F-KY Building, 1-8-11 Kita-Shinagawa, Shinagawa-Ku, Tokyo 140 Japan
Telephone (*) 81-3-5462-8191, Fax (*) 81-3-5462-8195

KOREA

Dresser Korea, Inc.
#2107 Kuk Dong Building, 60-1, 3-Ka, Choongmu-ro, Chung-Ku, Seoul, Korea
Telephone (*) 82-2-274-0792, Fax (*) 82-2-274-0794

MEXICO

Masoneilan Internacional S.A. de C.V.
Av. Henry Ford No. 114, Apartado Postal 572, 54030 Tlalneptla, Mexico
Telephone (*) 52-5-310-9863, Fax (*) 52-5-310-5584

SAUDI ARABIA

Dresser Al Rushaid Valve & Instrument Co., Ltd.
P.O. Box 10145, Jubail Industrial City 31961, Kingdom of Saudi Arabia
Telephone (*) 966-3-341-0278, Fax (*) 966-3-341-7624

SINGAPORE

Dresser Valve & Controls Far East
16, Tuas Ave 8, Singapore 2263, Telephone (*) 65-861-6100, Fax (*) 65-861-7172

UNITED KINGDOM

Dresser Limited, Valve & Controls Division
P.O. Box 2234, 16 Edendale Road, Eastleigh, Edenvale 1610, Transvaal, Republic of South Africa
Telephone (*) 27-11-452-1550, Fax (*) 27-11-452-2903

Dresser U.K., Ltd., Industrial Valve Operation
Gillibrands Estate, Skelmersdale, Lancashire, WN8 9TU England
Telephone (*) 44-1695-52600, Telex (851) 627039, Fax (*) 44-1695-720175

Dresser U.K., Ltd., Industrial Valve Operation
Howe Moss Drive, Kirkhill Industrial Estate, Dyce, Aberdeen, AB2 OGL, Scotland
Telephone (*) 44-1224-773187, Fax (*) 44-1224-773190

VENEZUELA

Riese & CIA S.A.
Apartado 372, Caracas, Venezuela
Telephone (*) 58-2-541-3812, Fax (*) 58-2-545-2702

(*) The appropriate International Access Code will need to precede the telephone/fax number if you are placing a call to a location outside of your country.

CONSOLIDATED® is a registered trademark
of Dresser Industries, Inc.
© Dresser Industries, Inc.



Dresser Industries, Inc.
Industrial Valve Operation
Alexandria, Louisiana 71309-1430 (USA)