

# 4900 MPV

## Pilot-Operated Safety Relief Valve

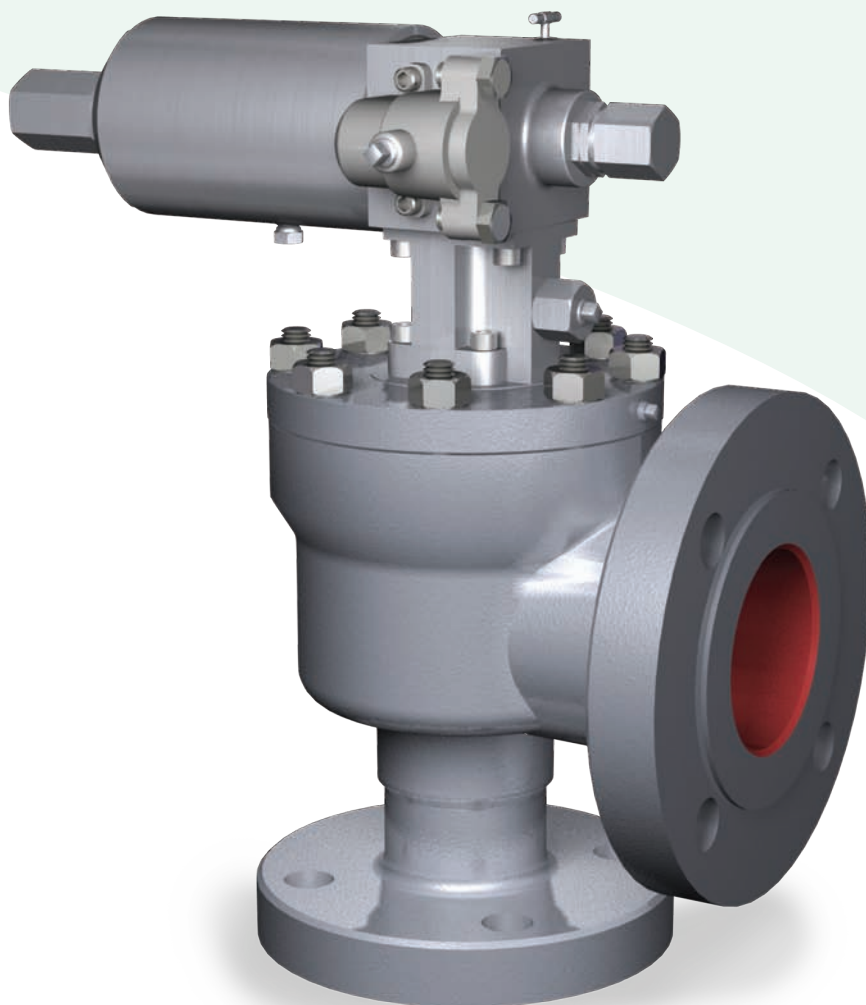

## Table of Contents

Features / Scope of Design .....	4900.2
Pressure / Temperature (USCS) .....	4900.6
Dimensions & Weights .....	4900.7
Main Valve Materials .....	4900.9
Soft Goods Selection .....	4900.11
Pop Pilot Operation .....	4900.13
Modulating Pilot Operation .....	4900.14
Pilot Materials 49PV07 & 49MV07 .....	4900.15
Pilot Materials 49MV22 & 49MV72 .....	4900.17
Pilot Valve Standard Accessories .....	4900.19
Pilot Valve Optional Accessories .....	4900.20
Capacities (USCS) .....	4900.21

### 4900 MPV

4900 Flanged Valves comply with:

- ASME B & PVC, Section VIII, Division I
- ASME Section II
- NACE MRO103
- D.O.T. Subchapter D Parts 192 and 195
- ISO 4126-4
- API 520, API 526, and API 527
- ANSI B16.34
- ANSI B16.5



**49PV07**



**49MV07**



**49MV22**



**49MV72**

## 4900 Flanged Series Overview

### Tubeless Design

Consolidated®, the world leader in providing pressure relief valve solutions, was the first manufacturer of a tubeless pilot operated safety relief valve. That design has now been improved upon with the introduction of the new high performance tubeless 4900 MPV™.

No longer does the end user have to worry about tube damage that may occur during shipping, installation or operation. The need to review and approve customized tubing arrangements is eliminated. The effects on tubing, from vibration or atmospheric conditions, is no longer a major consideration. And when it comes time to maintain the product, the tubeless design is less complex and easier to disassemble and reassemble ensuring confidence in its continued performance.

### Environmentally Friendly

The 4900 MPV with its tubeless design is well suited in applications where there are environmental concerns. The 4900 pilot valve is a non-flowing pilot that only vents the dome volume and does not continue to vent when the main valve is fully open. The pilot is vented into the body bowl, without the use of tubing, and not into the atmosphere provided that a closed discharge system is being used. The modulating design allows the valve to open in proportion to the overpressure further reducing media loss and stabilizing system pressure. The reduced number of fittings and connections means fewer potential leakage points.

### High Performance Pilot Valve

The 4900 MPV is a high performance pilot valve that can be used where other spring loaded and pilot operated pressure relief valves fall short on performance. With excellent seat tightness and the ability to externally adjust blowdown, the 4900 MPV can perform within the demands of most operating requirements. It can continue to function at this high standard on single phase or multi-phase applications, such as water and steam, without affecting set pressure or blowdown settings.

There are several features on the new design that are considered standard and are provided at no extra cost. The following tables list the standard features and the available options for the 4900 MPV.

Standard Features	49PV07	49MV07	49MV22	49MV72
Tubeless Design	Yes	Yes	Yes	Yes
Field Test Connection	Yes	Yes	Yes	Yes
Bonnet Vented w/ breather filter	Yes	Yes	Yes	Yes
Backflow Preventer	Yes	Yes	Yes	Yes
Manual Blowdown Valve	Yes	Yes	Yes	Yes
100 micron in-body filter protects pilot	Yes	Yes	Yes	Yes
Pilot Body entirely stainless steel	Yes	Yes	Yes	Yes
Non-Flowing pilot vented to the outlet	Yes	Yes	Yes	Yes
Designed for ease of maintenance	Yes	Yes	Yes	Yes
Pop Action Design	Yes	No <sup>Note 2</sup>	No	No
Modulating Design	No <sup>Note 1</sup>	Yes	Yes	Yes

Notes: 1. Can be converted to a 49MV07 with the addition of a modulator assembly. 2. Can be converted to a 49PV07 with the removal of the modulator assembly.

Optional Features	49PV07	49MV07	49MV22	49MV72
Remote Sensing	Yes	Yes	Yes	Yes
Pilot Valve Tester	Yes	Yes	Yes	Yes
Pressure Differential Switch	Yes	Yes	Yes	Yes
High Capacity Canister Filter (with flush valve) <sup>Note: 1&amp;2</sup>	Yes	Yes	Yes	Yes
Pneumatic or Electrical Blowdown	Yes	Yes	Yes	Yes

Notes: 1. A high capacity filter is recommended for steam service. 2. A special Inlet Adaptor is required with the Canister Filter Option.

## 4900 Flanged Series Overview

Applications	49PV07	49MV07	49MV22	49MV72
<b>Type</b>				
Pop Action - Non Flowing	Yes	No <sup>Note 2</sup>	No	No
Modulating - Non Flowing	No <sup>Note 1</sup>	Yes	Yes	Yes
<b>Media</b>				
Air Service	Yes	Yes	Yes	Yes
Gas Service	Yes	Yes	Yes	Yes
Liquid Service	Yes	Yes	Yes	Yes
Steam Service	Yes	Yes	No	No
Dry Vapor (filter required)	Yes	Yes	Yes	Yes
<b>Operational Conditions</b>				
Icing	Yes	Yes	Yes	Yes
Pulsation	Yes	Yes	Yes	Yes
Reduces Water Hammer (when valve closes)	Yes	Yes	Yes	Yes
Dirty Service Option	No	No	No	No
<b>Operational Performance</b> <sup>Note: 3, 4, 5 &amp; 6</sup>				
Pressure Range (PSIG)	15-750	15-750	751-3750	3751-7200
Full Lift at ___% of Set Pressure	100%	110%	110%	110%
Set point repeatability to within	+/-2%	+/-2%	+/-2%	+/-2%
Standard Factory Blowdown Setting	4%	3%	3%	3%
Adjustable Blowdown Range	2% to 7%	2% to 7%	3% to 7%	3% to 7%
Standard Factory Seat Tightness per API-527	96%	96%	96%	96%
Back Pressure (pilot vented to main valve)				
Constant Backpressure	65%	65%	65%	65%
Variable Backpressure	15%	65%	65%	65%

- NOTES: 1. Can be converted to a 49MV07 with the addition of a modulator assembly.  
2. Can be converted to a 49PV07 with the removal of the modulator assembly.  
3. Seat Tightness requirements above 90% of set pressure and relieving temperature above 400°F de-rate the allowable piping loads for the valve outlet. It is preferable that exhaust piping loads be a value of zero.  
4. Review the outlet flange rating and the capacity correction factor for valves with backpressure.  
5. A cold differential test pressure (CDTP) must be applied on all 49PVs with a constant back pressure that is over 15% of set pressure.  
6. Consult the factory for performance requirements that are different then those stated.

## 4900 Flanged Series Overview

### Pressure Limits<sup>Note: 1 & 2</sup>

Product Type	Pilot Type	Minimum (psig)	Maximum (psig)	Service
4900	49PV07	15	750	gas/liquid
4900	49MV07	15	750	gas/liquid
4900	49MV22	751	3750	gas/liquid
4900	49MV72	3751	7200	gas/liquid
4900	49PV07-SS	15	750	steam
4900	49MV07-SS	15	750	steam

### Temperature Limits<sup>Note: 1 & 2</sup>

Product Type	Pilot Type	Minimum (°F)	Maximum (°F)	Service
4900	49PV07	-40	505	gas/liquid
4900	49MV07	-40	505	gas/liquid
4900	49MV22	-40	505	gas/liquid
4900	49MV72	-40	505	gas/liquid
4900	49PV07-SS	212	505	steam
4900	49MV07-SS	212	505	steam

### Soft Goods Guide<sup>Note: 1 & 3</sup>

Service	Material	Pilot Valve and Modulator		Main Valve	
		Temperature Range (°F)	Pressure Range (psig)	Temperature Range (°F)	Pressure Range (psig)
liquid/gas	nitrile (Buna N)	-40 to 250	15 to 7200	-40 to 250	15 to 3750
liquid/gas	fluorocarbon (Viton)	-15 to 400	15 to 7200	-15 to 400	15 to 3750
liquid/gas	ethylene propylene	-40 to 400	15 to 7200	-40 to 400	15 to 3750
liquid/gas	Kalrez®	-40 to 505	15 to 7200	-40 to 505	15 to 3750
liquid/gas	Teflon	212 to 505	50 to 7200	-40 to 505	50 to 7200
liquid/gas	neoprene	N/A	N/A	-40 to 300	15 to 800
liquid/gas	silicone	N/A	N/A	-40 to 437	15 to 400
liquid/gas	Chemraz®	N/A	N/A	-20 to 425	15 to 3750
steam	ethylene propylene	212 to 500	15 to 680	212 to 500	15 to 680
steam	Teflon®	212 to 505	50 to 750	212 to 505	50 to 750

- NOTES:
1. The above table is general in nature and is to be used as a guideline only.
  2. Refer to the "Pressure/Temperature" Chart on page 4900.6 for actual pressure limits at a given temperature by pressure class and materials of construction.
  3. Refer to the "Soft Goods Selection" Chart on page 4900.11 & 4900.12 for material selection for a given pressure, temperature, fluid type, durometer hardness, and orifice size.

## 4900 Valve Selection

### Inlet x Outlet Size Combinations - Standard Bore Note: 1

Valve Size (in.) & Type	Orifices	Inlet Flange Size (in.) & Class	Outlet Flange Size (in.) & Class	Outlet Type
1 - 4905	D,E,F	1 - 150	2 - 150	Single
1 - 4910	D,E,F	1 - 300	2 - 150	Single
1 - 4912	D,E,F	1 - 600	2 - 150	Single
1 - 4914	D,E,F	1 - 900	2 - 300	Single
1 - 4916	D,E,F	1 - 1500	2 - 300	Single
1 - 4918	D,E,F	1 - 2500	2 - 300	Single
1-1/2 - 4905	D,E,F	1-1/2 - 150	2 - 150	Single
1-1/2 - 4910	D,E,F	1-1/2 - 300	2 - 150	Single
1-1/2 - 4912	D,E,F	1-1/2 - 600	2 - 150	Single
1-1/2 - 4914	D,E,F	1-1/2 - 900	2 - 300	Single
1-1/2 - 4916	D,E,F	1-1/2 - 1500	2 - 300	Single
1-1/2 - 4918	D,E,F	1-1/2 - 2500	2 - 300	Single
1-1/2 - 4905	G,H	1-1/2 - 150	3 - 150	Single
1-1/2 - 4910	G,H	1-1/2 - 300	3 - 150	Single
1-1/2 - 4912	G,H	1-1/2 - 600	3 - 150	Single
1-1/2 - 4914	G,H	1-1/2 - 900	3 - 300	Single
1-1/2 - 4916	G,H	1-1/2 - 1500	3 - 300	Single
1-1/2 - 4918	G,H	1-1/2 - 2500	3 - 300	Single
2 - 4905	G,H,J	2 - 150	3 - 150	Single
2 - 4910	G,H,J	2 - 300	3 - 150	Single
2 - 4912	G,H,J	2 - 600	3 - 150	Single
2 - 4914	G,H,J	2 - 900	3 - 300	Single
2 - 4916	G,H,J	2 - 1500	3 - 300	Single
2 - 4918	G,H,J	2 - 2500	3 - 300	Single
3 - 4905	J,K,L	3 - 150	4 - 150	Single
3 - 4910	J,K,L	3 - 300	4 - 150	Single
3 - 4912	J,K,L	3 - 600	4 - 150	Single
3 - 4914	J,K,L	3 - 900	4 - 300	Single
3 - 4916	J,K,L	3 - 1500	4 - 300	Single
3 - 4918	J,K,L	3 - 2500	4 - 300	Single
4 - 4905	L,M,N,P	4 - 150	6 - 150	Single
4 - 4910	L,M,N,P	4 - 300	6 - 150	Single
4 - 4912	L,M,N,P	4 - 600	6 - 150	Single
4 - 4914	L,M,N,P	4 - 900	6 - 300	Single
4 - 4916	L,M,N,P	4 - 1500	6 - 300	Single
6 - 4905	Q,R	6 - 150	8 - 150	Single
6 - 4910	Q,R	6 - 300	8 - 150	Single
6 - 4912	Q,R	6 - 600	8 - 150	Single
8 - 4905	T	8 - 150	10 - 150	Single
8 - 4910	T	8 - 300	10 - 150	Single
8 - 4912	T	8 - 600	10 - 150	Single

### 4900 Standard Bore Orifice Area (Sq. in.)

<b>ASME</b>	0.1314	0.228	0.359	0.594	0.930	1.513	2.160	3.350	4.229	5.098	7.491	12.979	18.783	30.542
<b>API</b>	0.110	0.196	0.307	0.503	0.785	1.287	1.838	2.853	3.60	4.34	6.38	11.05	16.00	26.00
<b>ORIFICE</b>	D	E	F	G	H	J	K	L	M	N	P	Q	R	T

NOTE: 1. The center line to face dimensions and the Inlet/Outlet combinations of the 4900 meet API Standard 526-2002 for pilot operated valves.

# USCS Pressure - Temperature Rating Charts

## SA216 WCC Carbon Steel

## SA351 CF8M Stainless Steel

Type	4905	4910	4912	4914	4916	4918	4905	4910	4912	4914	4916	4918
Pressure Class From -20°F to:	150	300	600	900	1500	2500	150	300	600	900	1500	2500
100	290	750	1500	2250	3750	6250	275	720	1440	2160	3600	6000
110	287	750	1500	2250	3750	6250	271	710	1420	2130	3549	5916
120	284	750	1500	2250	3750	6250	268	700	1400	2100	3499	5832
130	281	750	1500	2250	3750	6250	264	690	1380	2070	3448	5748
140	278	750	1500	2250	3750	6250	261	680	1360	2040	3398	5664
150	275	750	1500	2250	3750	6250	257	670	1340	2010	3347	5580
160	272	750	1500	2250	3750	6250	254	660	1320	1980	3297	5496
170	269	750	1500	2250	3750	6250	250	650	1300	1950	3246	5412
180	266	750	1500	2250	3750	6250	247	640	1280	1920	3196	5328
190	263	750	1500	2250	3750	6250	243	630	1260	1890	3145	5244
200	260	750	1500	2250	3750	6250	240	620	1240	1860	3095	5160
210	257	748	1495	2243	3739	6232	237	614	1228	1842	3065	5110
220	254	746	1491	2237	3728	6214	235	608	1216	1824	3035	5060
230	251	744	1486	2230	3717	6196	232	602	1204	1806	3005	5010
240	248	742	1482	2224	3706	6178	230	596	1192	1788	2975	4960
250	245	740	1477	2217	3695	6160	227	590	1180	1770	2945	4910
260	242	738	1473	2211	3684	6142	225	584	1168	1752	2915	4860
270	239	736	1468	2204	3673	6124	222	578	1156	1734	2885	4810
280	236	734	1464	2198	3662	6106	220	572	1144	1716	2855	4760
290	233	732	1459	2191	3651	6088	217	566	1132	1698	2825	4710
300	230	730	1455	2185	3640	6070	215	560	1120	1680	2795	4660
310	227	727	1450	2178	3629	6051	213	555	1111	1666	2772	4622
320	224	725	1446	2171	3618	6032	211	551	1102	1652	2750	4584
330	221	722	1441	2164	3607	6013	209	546	1093	1638	2727	4546
340	218	720	1437	2157	3596	5994	207	542	1084	1624	2705	4508
350	215	717	1432	2150	3585	5975	205	537	1075	1610	2682	4470
360	212	715	1428	2143	3574	5956	203	533	1066	1596	2660	4432
370	209	712	1423	2136	3563	5937	201	528	1057	1582	2637	4394
380	206	710	1419	2129	3552	5918	199	524	1048	1568	2615	4356
390	203	707	1414	2122	3541	5899	197	519	1039	1554	2592	4318
400	200	705	1410	2115	3530	5880	195	515	1030	1540	2570	4280
410	197	701	1402	2103	3509	5846	192	511	1022	1529	2552	4250
420	194	697	1394	2091	3489	5812	190	508	1015	1519	2534	4220
430	191	693	1386	2079	3468	5778	187	504	1007	1508	2516	4190
440	188	689	1378	2067	3448	5744	185	501	1000	1498	2498	4160
450	185	685	1370	2055	3427	5710	182	497	992	1487	2480	4130
460	182	681	1362	2043	3407	5676	180	494	985	1477	2462	4100
470	179	677	1354	2031	3386	5642	177	490	977	1466	2444	4070
480	176	673	1346	2019	3366	5608	175	487	970	1456	2426	4040
490	173	669	1338	2007	3345	5574	172	483	962	1445	2408	4010
500	170	665	1330	1995	3325	5540	170	480	955	1435	2390	3980
505	168	662	1324	1986	3310	5515	168	478	952	1431	2383	3969

## 49MPV Series - Dimensions & Weights

### Single Outlet, Standard Bore

Valve Size (in.) & Type	Orifices	Inlet Flange Size (in.) & Class	Outlet Flange Size (in.) & Class	A in. (mm)	B in. (mm)	C in. (mm)	D in. (mm)	WEIGHT lb. (kg)
1 - 4905	D,E,F	1 - 150	2 - 150	4-1/8 (104.8)	4-1/2 (114.3)	7-11/16 (195.3)	10-7/8 (276.2)	42 (19.1)
1 - 4910	D,E,F	1 - 300	2 - 150	4-3/8 (111.1)	4-1/2 (114.3)	8 (203.2)	10-7/8 (276.2)	43 (19.5)
1 - 4912	D,E,F	1 - 600	2 - 150	4-3/8 (111.1)	4-1/2 (114.3)	8 (203.2)	10-7/8 (276.2)	46 (20.9)
1 - 4914	D,E,F	1 - 900	2 - 300	4-15/16 (125.4)	4-3/4 (120.7)	8-1/2 (215.9)	10-7/8 (276.2)	52 (23.6)
1 - 4916	D,E,F	1 - 1500	2 - 300	4-15/16 (125.4)	4-3/4 (120.7)	8-1/2 (215.9)	10-7/8 (276.2)	52 (23.6)
1 - 4918	D,E,F	1 - 2500	2 - 300	4-15/16 (125.4)	4-3/4 (120.7)	7-13/16 (198.4)	10-7/8 (276.2)	58 (26.3)
1-1/2 - 4905	D,E,F	1-1/2 - 150	2 - 150	4-7/8 (123.8)	4-3/4 (120.7)	8-7/16 (214.3)	10-7/8 (276.2)	48 (22.0)
1-1/2 - 4910	D,E,F	1-1/2 - 300	2 - 150	4-7/8 (123.8)	4-3/4 (120.7)	8-7/16 (214.3)	10-7/8 (276.2)	50 (22.7)
1-1/2 - 4912	D,E,F	1-1/2 - 600	2 - 150	4-7/8 (123.8)	4-3/4 (120.7)	8-7/16 (214.3)	10-7/8 (276.2)	50.2 (22.8)
1-1/2 - 4914	D,E,F	1-1/2 - 900	2 - 300	5-7/8 (149.2)	5-1/2 (139.7)	9-7/16 (239.7)	10-7/8 (276.2)	63.2 (28.7)
1-1/2 - 4916	D,E,F	1-1/2 - 1500	2 - 300	5-7/8 (149.2)	5-1/2 (139.7)	9-7/16 (239.7)	10-7/8 (276.2)	63.2 (28.7)
1-1/2 - 4918	D,E,F	1-1/2 - 2500	2 - 300	5-7/8 (149.2)	5-1/2 (139.7)	10-1/2 (266.7)	10-7/8 (276.2)	76 (34.5)
1-1/2 - 4905	G,H	1-1/2 - 150	3 - 150	5-1/8 (130.2)	4-7/8 (123.8)	11-15/16 (303.2)	10-7/8 (276.2)	53 (24.0)
1-1/2 - 4910	G,H	1-1/2 - 300	3 - 150	5-1/8 (130.2)	4-7/8 (123.8)	11-15/16 (303.2)	10-7/8 (276.2)	55 (24.9)
1-1/2 - 4912	G,H	1-1/2 - 600	3 - 150	5-1/8 (130.2)	4-7/8 (123.8)	11-15/16 (303.2)	10-7/8 (276.2)	57 (25.9)
1-1/2 - 4914	G,H	1-1/2 - 900	3 - 300	6-3/8 (161.9)	6-3/4 (171.5)	13-3/16 (335.0)	10-7/8 (276.2)	66 (29.9)
1-1/2 - 4916	G,H	1-1/2 - 1500	3 - 300	6-3/8 (161.9)	6-3/4 (171.5)	13-3/16 (335.0)	10-7/8 (276.2)	66 (29.9)
1-1/2 - 4918	G,H	1-1/2 - 2500	3 - 300	6-3/8 (161.9)	6-3/4 (171.5)	12-7/8 (327.0)	10-7/8 (276.2)	78 (35.4)
2 - 4905	G,H,J	2 - 150	3 - 150	5-3/8 (136.5)	4-7/8 (123.8)	10-1/16 (255.6)	10-7/8 (276.2)	56 (25.4)
2 - 4910	G,H,J	2 - 300	3 - 150	5-3/8 (136.5)	4-7/8 (123.8)	10-1/16 (255.6)	10-7/8 (276.2)	58 (26.3)
2 - 4912	G,H,J	2 - 600	3 - 150	5-3/8 (136.5)	4-7/8 (123.8)	10-1/16 (255.6)	10-7/8 (276.2)	60 (27.2)
2 - 4914	G,H,J	2 - 900	3 - 300	6-9/16 (166.7)	6-3/4 (171.5)	11-1/4 (285.8)	10-7/8 (276.2)	83 (37.6)
2 - 4916	G,H,J	2 - 1500	3 - 300	6-9/16 (166.7)	6-3/4 (171.5)	11-1/4 (285.8)	10-7/8 (276.2)	83 (37.6)
2 - 4918	G,H,J	2 - 2500	3 - 300	7 (177.8)	6-3/4 (171.5)	13-1/4 (336.6)	10-7/8 (276.2)	105 (47.6)
3 - 4905	J,K,L	3 - 150	4 - 150	6-1/8 (155.6)	6-3/8 (161.9)	11-5/8 (295.3)	10-7/8 (276.2)	83 (37.6)
3 - 4910	J,K,L	3 - 300	4 - 150	6-1/8 (155.6)	6-3/8 (161.9)	11-5/8 (295.3)	10-7/8 (276.2)	86 (39.0)
3 - 4912	J,K,L	3 - 600	4 - 150	6-3/8 (161.9)	6-3/8 (161.9)	11-7/8 (301.6)	10-7/8 (276.2)	90 (40.8)
3 - 4914	J,K,L	3 - 900	4 - 300	7-1/2 (190.5)	7-1/8 (181.0)	13-9/16 (344.5)	10-7/8 (276.2)	143 (64.9)
3 - 4916	J,K,L	3 - 1500	4 - 300	7-1/2 (190.5)	7-1/8 (181.0)	13-9/16 (344.5)	10-7/8 (276.2)	160 (72.9)
3 - 4918	J,K,L	3 - 2500	4 - 300	8-3/4 (222.3)	9 (228.6)	16-1/16 (408.0)	10-7/8 (276.2)	183 (83.0)

## 49MPV Series - Dimensions & Weights (Continued)

### Single Outlet, Standard Bore

Valve Size (in.) & Type	Orifices	Inlet Flange Size (in.) & Class	Outlet Flange Size (in.) & Class	A in. (mm)	B in. (mm)	C in. (mm)	D in. (mm)	WEIGHT lb. (kg)
4 - 4905	L,M,N,P	4 - 150	6 - 150	7-3/4 (196.9)	8-1/4 (209.6)	15 (381.0)	10-7/8 (276.2)	194 (88.0)
4 - 4910	L,M,N,P	4 - 300	6 - 150	7-3/4 (196.9)	8-1/4 (209.6)	15 (381.0)	10-7/8 (276.2)	202 (91.6)
4 - 4912	L,M,N,P	4 - 600	6 - 150	7-3/4 (196.9)	8-1/4 (209.6)	15 (381.0)	10-7/8 (276.2)	209 (94.8)
4 - 4914	L,M,N,P	4 - 900	6 - 300	9-13/16 (249.2)	9-3/16 (233.4)	17-15/16 (455.6)	10-7/8 (276.2)	243 (110.2)
4 - 4916	L,M,N,P	4 - 1500	6 - 300	9-13/16 (249.2)	9-3/16 (233.4)	17-15/16 (455.6)	10-7/8 (276.2)	262 (118.8)
6 - 4905	Q,R	6 - 150	8 - 150	9-7/16 (239.7)	9-1/2 (241.3)	18-7/16 (468.3)	10-7/8 (276.2)	351 (159.2)
6 - 4910	Q,R	6 - 300	8 - 150	9-7/16 (239.7)	9-1/2 (241.3)	18-7/16 (468.3)	10-7/8 (276.2)	370 (167.8)
6 - 4912	Q,R	6 - 600	8 - 150	9-11/16 (246.1)	9-1/2 (241.3)	18-11/16 (474.7)	10-7/8 (276.2)	419 (190.1)
8 - 4905	T	8 - 150	10 - 150	10-7/8 (276.2)	11 (279.4)	21-7/16 (544.5)	10-7/8 (276.2)	520 (235.9)
8 - 4910	T	8 - 300	10 - 150	10-7/8 (276.2)	11 (279.4)	21-7/16 (544.5)	10-7/8 (276.2)	548 (248.6)
8 - 4912	T	8 - 600	10 - 150	11-11/16 (296.9)	11 (279.4)	22-1/4 (565.2)	10-7/8 (276.2)	604 (274.0)

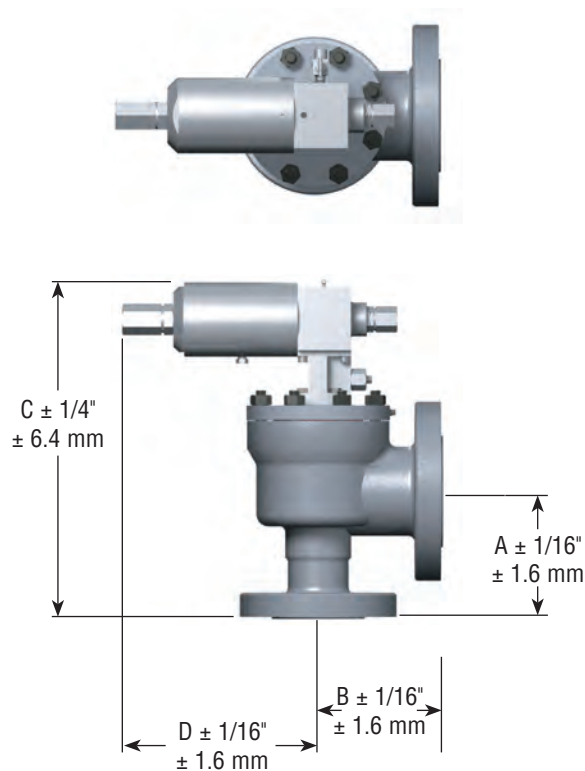

### 4900MPV Series w/ Single Outlet - Standard Bore

(Typical 49MV22 shown above)

Note: All weights listed in this document are approximations.

## 4900 Materials Overview - Main Valve

The main valve has six basic components. Assembly and disassembly are accomplished through top entry. This means that as long as there is no pressure in the system, routine maintenance, such as replacement of O-Rings and seals, may be done with the valve in place, virtually eliminating the need for cranes and additional manpower.

### Base

The base is cast with integral flanges. It forms the main structure and is a pressure boundary component since it will be exposed to process media. To ensure integrity and reliability, all base castings are produced to the latest edition to the ASME & Pressure Vessel Codes. The standard materials are Grade WCC carbon steel and Grade CF8M stainless steel. Other materials such as Monel, Hastelloy, and additional code approved materials are available to satisfy more demanding requirements.

### Nozzle

The 316 stainless steel nozzle performs two functions: First, it forms the lower seating surface. Second, the orifice is machined into the nozzle and controls the capacity when full lift is reached. The nozzle is threaded or bolted into the body and sealed with an O-Ring. By threading or bolting the nozzle into the base, it may be removed easily for repair or replacement.

### Guide

This one-piece guide of 316 stainless steel ensures true alignment of the disc and nozzle for positive, bubble tight sealing. The heavy guide construction is designed to prevent warping or egging when the valve is in service.

### Cover Plate

The cover plate secures the guide and seals the main body. Through passages in the cover plate and inlet adapter, the main valve is connected to the pilot valve eliminating the need for external tubing. Pressure sensing, backflow prevention and venting of the pilot to the base are accomplished through these passages. Each cover plate is drilled and tapped for eyebolts that are used for ease of assembly or disassembly of the main valve and for handling the assembled valve.

### Disc

The disc is 316 stainless steel. An O-Ring is used for isolating the dome chamber when used on air, gas or liquid service. A spring energized Teflon® seal is used on the topside of the disc for steam service and when Teflon® material is chosen for air, gas or liquid. Graphite impregnated Teflon guide ring (or rings) provide a low coefficient of friction for the guiding function between the disc and guide. An O-Ring Seat performs the primary sealing function for the disc to ensure bubble tightness. The metal-to-metal stop for the seat allows the valve to still

function, even if the O-Ring is damaged or destroyed. Two unique features distinguish the Consolidated O-Ring seat seal safety relief valve from any other design. These are the 50-degree load bearing seats and the slotted O-Ring retainer.

There are three essentials to a tighter and more secure seal:

#### 1. Concentric Alignment

The nozzle bore and O-Ring retainer are both machined to an angle of 50 degrees. This ensures that as the valve disc opens and closes the O-Ring is aligned concentrically against the lip of the nozzle. Close tolerance between the nozzle and the body also helps to ensure a tight seal when the valve is closed.

#### 2. Maximum Sealing Force

On the backside of the O-Ring retainer, there are two small slots. When the valve is closed, process media enters between the machined seat of the nozzle and O-Ring retainer, and proceeds up the slots behind the O-Ring. This pressure forces the O-Ring against the lip of the nozzle and the curved recess of the disc. As the pressure within the valve rises to set point, the O-Ring is pressed tightly against the nozzle to maximizing the sealing force until the set pressure is reached.

#### 3. O-Ring Retention

When the valve opens, the pressure behind the O-Ring escapes from the same slots on the O-Ring retainer. This prevents the O-Ring from being ejected. Additionally, the O-Ring encapsulating retainer prevents the O-Ring from being ejected by the high velocity, low-pressure, discharge inside the upper valve body.

### Sensing Tube (Retainer Nose, item 18) or (Retainer, item 23)

The sensing tube is machined from 316 stainless steel barstock and is threaded into the main valve disc. It extends downward to a location below the nozzle level. The sensing tube picks up the media pressure and feeds this pressure internally through the main valve to the pilot.

Main Valve Materials<sup>Note: 3</sup>

	Part	Standard Material	Entirely Stainless (S4)	NACE (SG1) - Internal Service Only
1	Base	ASME SA216 WCC Carbon Steel	ASME SA351CF8M WCC Stainless Steel	ASME SA216 WCC Carbon Steel
2	Cover Plate	ASME SA516-70 Carbon Steel	ASME SA240 316 Stainless Steel	ASME SA516-70 Carbon Steel
3	Cover Plate Cap Screw (inlet sizes 1" & 2")	SA193 B7 Alloy Steel	SA193 B8M Stainless Steel	SA193 B7 Alloy Steel
4	Cover Plate Nut (inlet size 3" & above)	SA194 2H Alloy Steel	SA194 8M Stainless Steel	SA194 2H Alloy Steel
5	Cover Plate O-Ring	Teflon®	Teflon®	Teflon®
6	Cover Plate Pipe Plug	316 SS	316 SS	316 SS
7	Cover Plate Stud (inlet size 3" & above)	SA193 B7 Alloy Steel	SA193 B8M Stainless Steel	SA193 B7 Alloy Steel
8	Disc	316 SS	316 SS	316 SS
9	Disc Energized Seal (When Used) <sup>Note: 1</sup>	Teflon®	Teflon®	Teflon®
10	Disc O-Ring (When Used) <sup>Note: 1</sup>	Select	Select	Select
11	Guide	316 SS	316 SS	316 SS
12	Guide O-Ring	Teflon®	Teflon®	Teflon®
13	Guide Ring(s)	Teflon®	Teflon®	Teflon®
14	Inlet Base Pipe Plug	316 SS	316 SS	316 SS
15	Nozzle	316 SS	316 SS	316 SS
16	Nozzle O-Ring	Teflon®	Teflon®	Teflon®
17	Outlet Base Pipe Plug (Not Shown)	316 SS	316 SS	316 SS
18	Retainer Nose (inlet size 3" & above)	316 SS	316 SS	316 SS
19	Retainer Nut	316 SS	316 SS	316 SS
20	Retainer Nut O-Ring	Teflon®	Teflon®	Teflon®
21	Retainer (inlet size 3" & above)	316 SS	316 SS	316 SS
22	Retainer Screw (inlet size 3" & above)	304 SS	304 SS	304 SS
23	Retainer, Integral Nose (inlet size 1" & 2")	316 SS	316 SS	316 SS
24	Seat O-Ring <sup>Note: 2</sup>	Select	Select	Select
25	Sensing Element	316 SS	316 SS	316 SS

NOTES: 1 Disc Seal (9) or a Disc-O-Ring (10) is required based on the service conditions. Refer to the O-Ring Selection Charts beginning on page 4900.11.

2 For the O-Ring Seat Selection, refer to the O-Ring Selection Charts beginning on page 4900.11.

3 Main base assemblies can be provided in special materials. Contact the factory for availability.

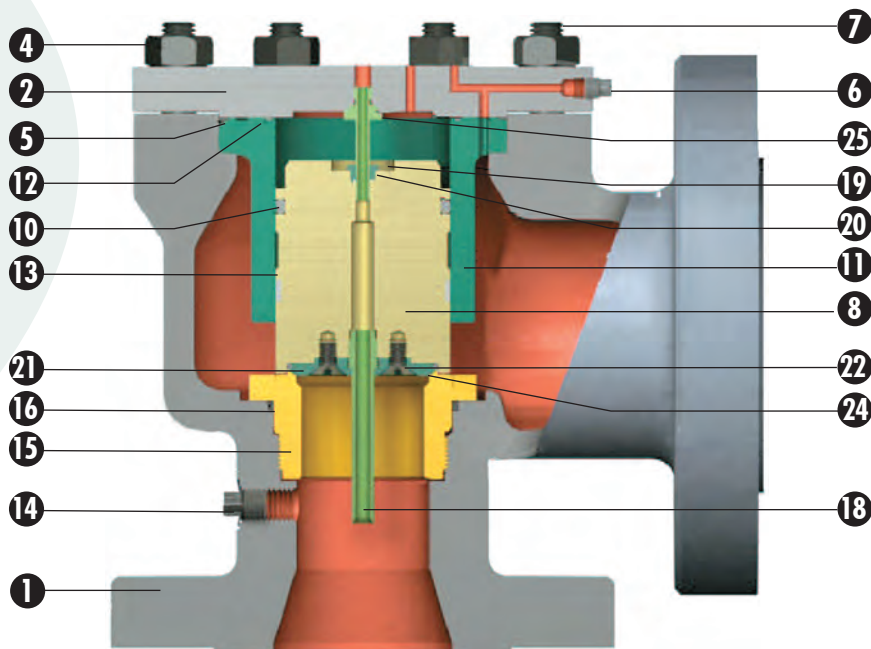

**G Through T Orifice Valves**

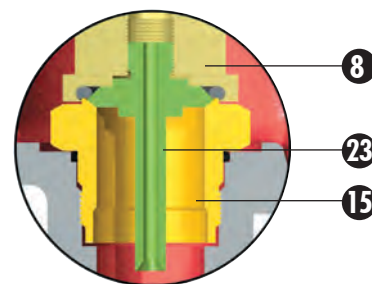

**D, E, & F Orifice valves**

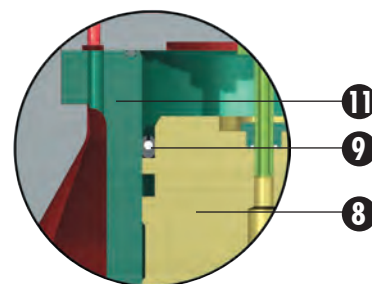

**Steam Service  
50 psig and above**

**Liquid, Gas and Air Service  
when O-Ring Seat (24) is Teflon®**

## Soft Goods Selection Chart

4900 Soft Goods Selection Chart				
Component	Description	Service		
		Liquid/Gas <sup>NOTE 3</sup> 15 to 7200 psig	Steam (49PV07 & 49MV07)	
			15 to 680 psig	50 to 750 psig
Main Valve	Guide Ring	Teflon®	Teflon®	Teflon®
	O-Ring (Cover Plate)	Teflon®	Teflon®	Teflon®
	O-Ring (Disc)	Note 1 & 2	ethylene/propylene 90	Not Required
	O-Ring (Guide)	Teflon®	Teflon®	Teflon®
	O-Ring (Nozzle)	Teflon®	Teflon®	Teflon®
	O-Ring (Retainer Nut)	Teflon®	Teflon®	Teflon®
	O-Ring (Seat)	SELECT	ethylene/propylene 90	Teflon®
	Spring Seal (Disc)	Note 2	Not Required	Teflon®
	O-Ring (Adjuster Bottom)	SELECT	ethylene/propylene 90	Teflon®
	O-Ring (Adjuster Top)	SELECT	ethylene/propylene 90	Teflon®
Pilot Valve	O-Ring (Back Flow Preventer Body)	SELECT	ethylene/propylene 90	Teflon®
	O-Ring (Ball Seat)	SELECT	ethylene/propylene 90	Teflon®
	O-Ring (Field Test Body)	SELECT	ethylene/propylene 90	Teflon®
	O-Ring (Inlet Adaptor)	SELECT	ethylene/propylene 90	Teflon®
	O-Ring (Insert)	SELECT	ethylene/propylene 90	Teflon®
	O-Ring (Main Base)	SELECT	ethylene/propylene 90	Teflon®
	O-Ring (Top Plate)	SELECT	ethylene/propylene 90	Teflon®
	O-Ring (Vent Port Assembly)	SELECT	ethylene/propylene 90	Teflon®
	Spring Seal (Adjuster Top)	Teflon®	Teflon®	Teflon®
	Spring Seal (Insert)	Teflon®	Teflon®	Teflon®
Modulator (49MV07)	Spring Seal (Main Piston)	Teflon®	Teflon®	Teflon®
	Spring Seal (Vent Seal Adaptor)	Teflon® (49MV22 & 49MV72 only)	N/A	N/A
	O-Ring (Modulator Base)	SELECT	ethylene/propylene 90	Teflon®
	O-Ring (Modulator Stop)	SELECT	ethylene/propylene 90	Teflon®
	O-Ring (Modulator Seat)	SELECT	ethylene/propylene 90	Teflon®
	O-Ring (Piston Bottom)	SELECT	ethylene/propylene 90	Teflon®
	Spring Seal (Piston Bottom)	Teflon®	Teflon®	Teflon®
	Spring Seal (Piston Top)	Teflon®	Teflon®	Teflon®

NOTES: 1 The Disc O-Ring (10) will be the same material and durometer as that selected for the Seat O-Ring(24).

2 When Teflon® material is selected for the Seat O-Ring(24), a Teflon® energized Disc Seal (9) will be provided rather than the Disc O-Ring (10).

3 Select soft good using charts for pressure, temperature & service. See selection instructions below.

### Soft Goods selection for liquid and gas service is accomplished as follows:

#### A) Material Selection

- Refer to Technical Information Section, O-Ring Selection beginning on page TI.22.
- Locate valve fluid and read the applicable O-Ring material.
- For fluids not listed, the customer must specify the O-Ring material.

#### B) Main Valve Pressure Limits

- Refer to Table 1 on page 4900.12.
- Locate the valve orifice and select the durometer for the required set pressure.

#### C) Main Valve Temperature Limits

- Refer to Table 2 on page 4900.12.
- Locate the material and durometer and verify the temperature limits.
- If temperature limits are exceeded, repeat Steps A & B.
- If an O-Ring cannot be selected, contact the factory.

#### D) Pilot Valve Pressure and Temperature Limits

- Refer to Table 3 on page 4900.12.
- Locate the service and review the pressure and temperature ranges, then select the material and durometer.

## Soft Goods Selection (Continued)

**Table 1 - Main Valve Pressure Limits (psig)<sup>NOTE: 1</sup>**

Inlet Size (in.)	Orifice	Durometer						Teflon <sup>®</sup> NOTE: 3			
		50		70 - 75 <sup>NOTE: 2</sup>		90		-40°F to +200°F		+201°F to +505°F	
		Min.	Max.	Min.	Max.	Min.	Max.	Min.	Max.	Min.	Max.
1	D, E, F	N/A	N/A	15	800	200	3750	1000	7200	50	7200
1-1/2	D, E, F	N/A	N/A	15	800	200	3750	1000	7200	50	7200
1-1/2	G, H	N/A	N/A	15	780	150	3750	1000	7200	50	7200
2	G, H, J	N/A	N/A	15	780	150	3750	1000	7200	50	7200
3	J, K, L	N/A	N/A	15	580	150	3750	1000	7200	50	7200
4	L, M, N, P	N/A	N/A	15	580	75	3750	1000	3750	50	3750
6	Q, R	N/A	N/A	15	420	60	1500	600	1500	50	1500
8	T	N/A	N/A	15	200	30	1500	300	1500	50	1500

- NOTES: 1 Disc O-Ring (10) will be of the same material and durometer as that selected for the Seat O-Ring (24).  
 2 Maximum set pressure for silicone compounds is half of the maximum value.  
 3 When Teflon<sup>®</sup> material is selected for the Seat O-Ring (24) a Teflon<sup>®</sup> energized seal will be provided for the Disc Seal (9).

**Table 2 - Main Valve Temperature Limits (°F)**

Material	Durometer	NOTES	Temperature Limits		Material	Durometer	NOTES	Temperature Limits	
			Min.	Max.				Min.	Max.
Nitrile (Buna-N)	70	2	-40	250	Silicone	70		-40	437
	90		-40	250	Teflon <sup>®</sup>	N/A		-40	505
Ethylene/Propylene	70	3	-40	212	Kalrez <sup>®</sup>	82	1	-40	505
	90		-40	250		75		-4	505
Fluorocarbon (Viton)	75		-15	400	91	1	-35	505	
	90		-15	400	75	1	-20	425	
Neoprene	70		-40	300	Chemraz <sup>®</sup>	90	1	-20	425

- NOTES: 1 Consult factory concerning the use of Kalrez<sup>®</sup> and Chemraz<sup>®</sup>.  
 2 Standard O-Ring Material  
 3 For steam, 90 durometer Ethylene/Propylene has a maximum temperature of 500°F.

**Table 3 - Pilot Valve and Modulator Pressure/Temperature Limits**

Service	O-Ring Material <sup>NOTE 2</sup>	Durometer	Temperature Limit (°F)		Pressure Limit (psig)	
			Min.	Max.	Min.	Max.
Liquid / Gas	Nitrile (Buna-N) <sup>NOTE 3</sup>	70	-40	250	15	3750
Liquid / Gas	Nitrile (Buna-N)	90	-40	250	3751	7200
Liquid / Gas	Fluorocarbon (Viton)	75	-15	400	15	3750
Liquid / Gas	Fluorocarbon (Viton)	90	-15	400	3751	7200
Liquid / Gas	Ethylene / Propylene	70	-40	212	15	3750
Liquid / Gas	Ethylene / Propylene	90	-40	250	3751	7200
Liquid / Gas	Kalrez <sup>®</sup> <sup>NOTE 1</sup>	—	-40	505	15	7200
Liquid / Gas	Teflon <sup>®</sup>	N/A	212	505	50	7200
Steam	Ethylene / Propylene	90	212	500	15	680
Steam	Teflon <sup>®</sup>	N/A	212	505	50	750

- NOTES: 1 Consult factory concerning the use of Kalrez<sup>®</sup>.  
 2 Other materials are on application. Consult factory for availability of other materials.  
 3 Standard O-Ring Material

## Pop Pilot Operation

In the operation of a pop pilot valve, there are two main components that control the operation of the valve. They are the main valve and the pilot valve.

In the main valve, system pressure is in direct contact with the seating surface on the bottom of the main valve disc; and at the same time, system pressure is fed through the pilot valve and interconnecting pipe to the dome area on the top of the disc. This equalizes the dome pressure on the top of the disc with the inlet pressure on bottom of the disc. Since the area of the top of the disc is larger than the area of the seating surface, the differential area results in a net downward force keeping the main valve tightly closed. In effect, as the system pressure increases, the downward sealing force increases on the main valve disc and the main valve disc becomes even tighter.

The adjustable spring compression on the pilot valve determines the set pressure of the valve. The system pressure acts against the effective seating area of the pilot valve piston and produces an opening force that counters the closing force of the pilot valve spring. As inlet pressure increases, the pilot piston strokes and seals off the main valve inlet pressure from the dome pressure. The pilot simultaneously opens the vent seal that relieves the dome pressure to atmospheric pressure. The main valve disc is allowed to lift off the seat as the fluid force overcomes the now vented pressure load above the main valve disc. The valve discharges to relieve system pressure. (The pilot is a non-flowing pilot and only the initial dome volume is vented.)

When the discharging main valve reduces the inlet pressure to the adjusted blowdown pressure of the pilot, the pilot piston closes the vent seal. Simultaneously, the inlet seal is reopened in the pilot. The main valve inlet pressure is again allowed to enter the dome above the main valve disc. As the dome pressure equalizes with the inlet pressure, the downward force created by the differential areas of the disc closes the main valve.

In chart (A) it can be seen that as dome pressure above the main valve disc increases with an increase in system pressure, the main valve sealing force also increases. Then the pilot valve vents the dome pressure eliminating the main disc sealing force and the main valve opens at its set pressure. Chart (B) shows that the system pressure increases and when the set pressure is reached, the valve immediately opens to full lift. The closing point of the valve can be adjusted within a range of 98% to 93% of the set pressure in order to meet the system requirements.

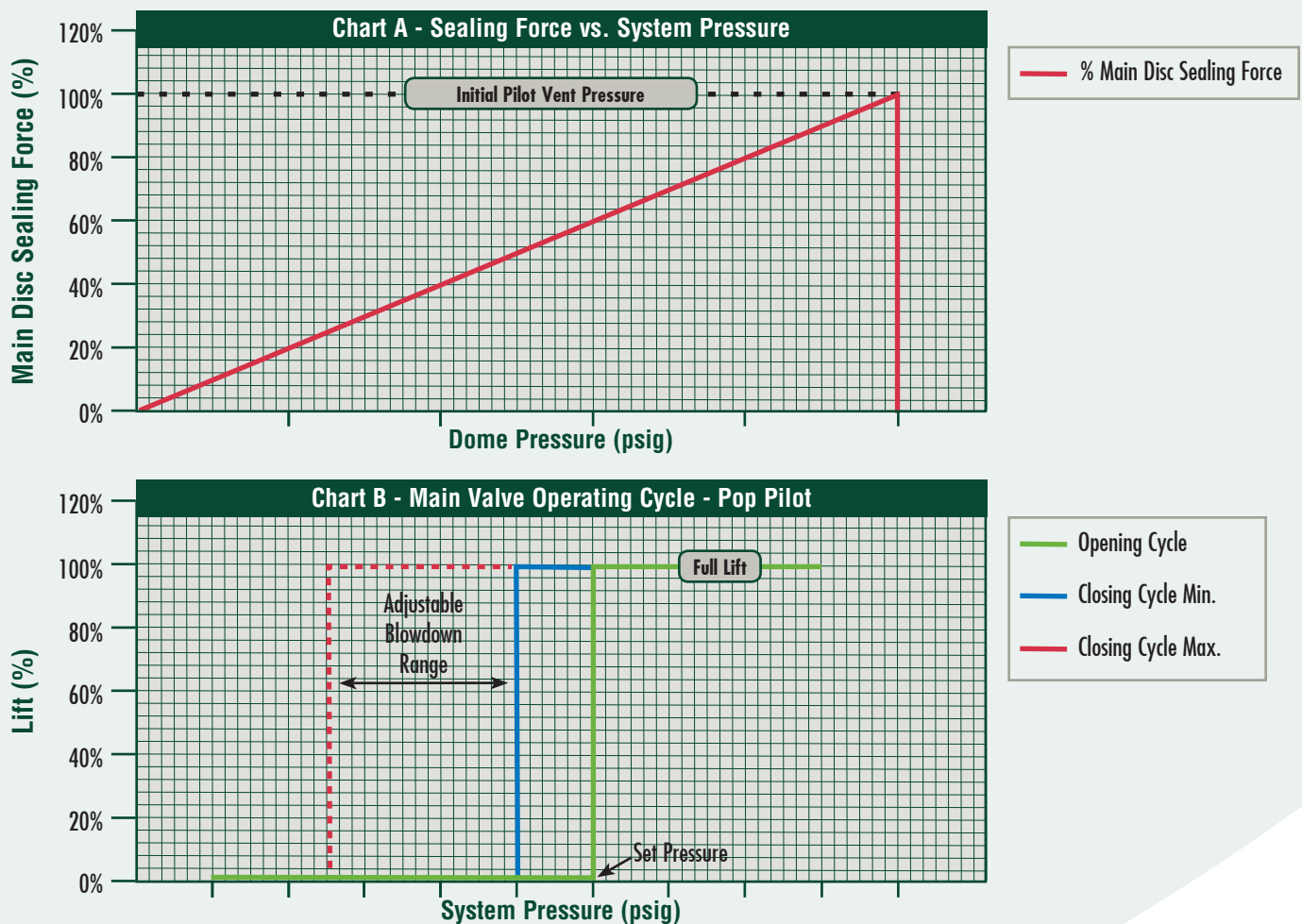

## Modulating Pilot Operation

In the operation of a modulating pilot valve (49MV07), there are three main components that control the operation of the valve. They are the main valve, the pilot valve and the modulator. (For the 49MV22 and 49MV72, the modulator is built internally into the pilot valve.)

In the main valve, system pressure is in direct contact with the seating surface on the bottom of the main valve disc; and at the same time, system pressure is fed through the pilot valve and interconnecting pipe to the dome area on the top of the disc. This equalizes the dome pressure on the top of the disc with the inlet pressure on bottom of the disc. Since the area on top of the disc is larger than the area of the seating surface, the differential area results in a net downward force keeping the main valve tightly closed. In effect, as the system pressure increases, the downward sealing force increases on the main valve disc and the main valve disc becomes even tighter.

As inlet pressure increases, the pilot piston strokes and seals off the main valve inlet pressure from the dome pressure. In the 49MV07, the pilot simultaneously opens the adjuster top seal and connects the dome pressure to the modulator. The modulator vents the dome pressure incrementally in proportion to the overpressure until set pressure and then full lift is reached. (In the 49MV22 and 49MV72, the dome pressure and adjuster bottom pressure are equal. As the system pressure increases, the vent seat adaptor seal opens and vents the dome pressure incrementally in proportion to the overpressure until set pressure and finally full lift is reached.)

When the discharging valve reduces the inlet pressure, the modulator or vent seat adaptor seal incrementally closes the main valve until the adjusted blowdown setting of the pilot is reached then the pilot piston closes the vent seal. Simultaneously, the inlet seal is reopened in the pilot. The main valve inlet pressure is again allowed to enter the dome above the main valve disc. As the dome pressure equalizes with the inlet pressure, the downward force created by the differential areas of the disc closes the main valve.

In chart (C) it can be seen that as dome pressure increases with an increase in system pressure, the main valve sealing force also increases. The pilot valve opens and then the valve modulator will incrementally vent dome pressure. The main disc sealing force is reduced in stages and at set point the main valve opens. As the system pressure continues to increase, the modulator continues to incrementally vent dome pressure thereby further reducing the main valve sealing force until full lift is achieved. Chart (D) shows that when the set pressure is reached, the main valve begins to open gradually with increases in system pressure until full lift is obtained. In order to meet the specific requirements of the operating system, the closing point of the valve can be adjusted within a range of 93% to 98% of the set pressure for the 49MV07. (For the 49MV22 and 49MV72 the adjustable blowdown range is from 93% to 97% of set pressure.)

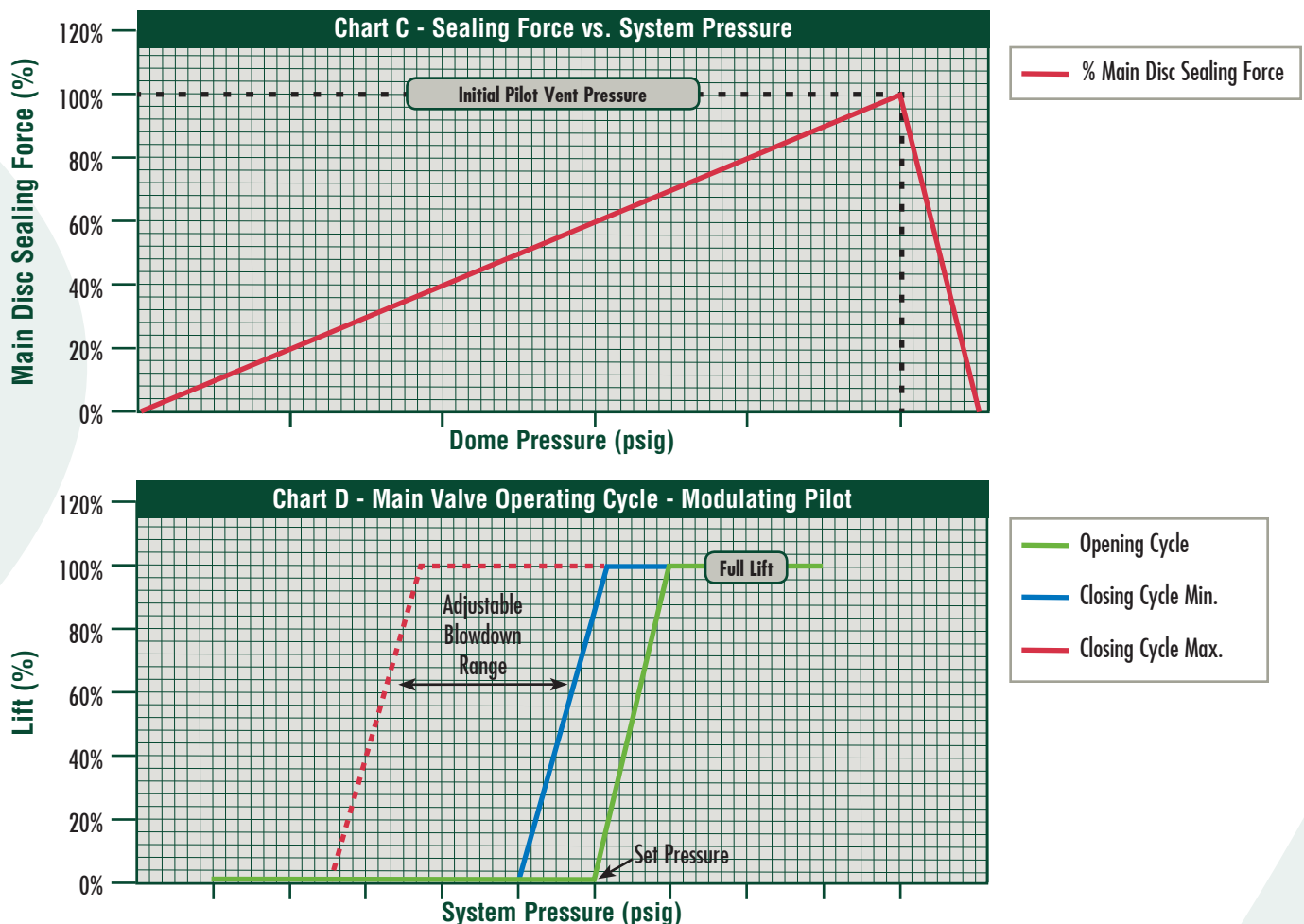

## 4900 Series Type 49PV07

Pop Action, Non-Flowing For Set Pressures 15 psig to 750 psig

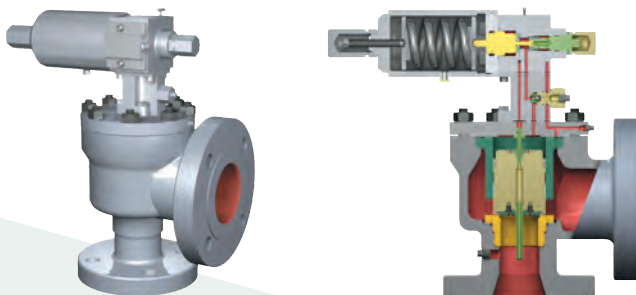

### 49PV07 Pop Action

## 4900 Series Type 49MV07

Modulating Action, Non-Flowing For Set Pressures 15 psig to 750 psig

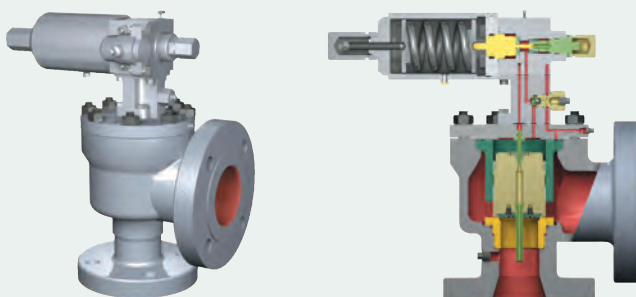

### 49MV07 Modulating Action

Modulating Assembly (49MV07 only) <sup>NOTE: 1 &amp; 3</sup>		
	Part	Material
1	Modulator Base	SA351 Grade CF8M Stainless Steel
2	Modulator Piston Bottom	316 SS
3	Modulator Piston Top	316 SS
4	Modulator Stop	SA351 Grade CF8M Stainless Steel
5	O-Ring Retainer	316 SS
6	Modulator Cap Screw (2)	316 SS
7	Lock Screw	316 SS
8	O-Ring (Modulator Stop) (2)	Select
9	O-Ring (Modulator Base) (2)	Select
10	O-Ring (Modulator Seat)	Select
11	O-Ring (Modulator Piston Bottom)	Select
12	Spring Seal (Modulator Piston Bottom)	Teflon®
13	Spring Seal (Modulator Piston Top)	Teflon®
14	Cap Screws (2) (not shown)	316 SS
15	Pipe Plug	316 SS

Pop Action <sup>NOTE: 1</sup>		
	Part	Material
1	Adjuster Bottom	316 SS
2	O-Ring (Adjuster Bottom)	Select
3	Adjuster Cap	316 SS
4	Adjuster Lock Nut	316 SS
5	Adjuster Top	316 SS
6	O-Ring (Adjuster Top)	Select
7	Spring Seal (Adjuster Top)	Teflon®
8	Backflow Preventer Assembly	-
a	Backflow Preventer Body	316 SS
b	Backflow Preventer Guide	316 SS
c	Ball	316 SS
d	O-Ring (Backflow Preventer Body) Small	Select
e	O-Ring (Backflow Preventer Body) Large	Select
f	O-Ring (Ball Seat) (2)	Select
g	Pipe Plug	316 SS
9	Bonnet	SA351 Grade CF8M SS
10	Breather Filter Vent (Bonnet)	Bronze/Steel
11	Cap Screw (Top Plate) (4)	316 SS
12	Cap Screw (Inlet Adaptor) (8)	316 SS
13	Compression Screw	316 SS
14	Compression Screw Cap	316 SS
15	Compression Screw Lock Nut	316 SS
16	Field Test Connection Assembly	-
a	Field Test Body	316 SS
b	Ball	316 SS
c	Tube Filter	316 SS
d	O-Ring (Field Test Body) Small	Select
e	O-Ring (Field Test Body) Large	Select
f	O-Ring (Ball Seat) (2)	Select
g	Pipe Plug	316 SS
17	Inlet Adaptor	316 SS
18	O-Ring (Inlet Adaptor) 3 Sizes	Select
19	Insert Bottom	316 SS
20	O-Ring (insert)	Select
21	Spring Seal (Insert)	Teflon®
22	Insert Top	316 SS
23	Main Base	316 SS
24	O-Ring (Main Base) (3)	Select
25	Needle Valve (not shown)	316 SS
26	Pipe Plug (not shown)	316 SS
27	Piston Assembly	-
a	Main Piston	316 SS
b	Spring Seal (Main Piston)	Teflon®
28	Set Screw (Bonnet)	316 SS
29	Spring (Phosphated) <sup>NOTE: 2</sup>	Chrome Steel
30	Spring Washer (2)	316 SS
31	Top Plate	316 SS
32	O-Ring (Top Plate)	Select
33	Vent Port Assembly	-
a	Ball	316 SS
b	Cap Screw (2) (not shown)	316 SS
c	O-Ring (Ball Seat)	Select
d	Pipe Plug (49PV07 Only) <sup>NOTE: 3</sup>	316 SS
e	Port Adaptor (49PV07 Only) <sup>NOTE: 3</sup>	316 SS
f	Spring	316 SS
g	O-Ring Vent Port Assembly (2)	Select

NOTE: 1 Pilot assemblies can be provided in special materials. Contact the factory for availability.

2 A 316 Stainless Steel spring is supplied on steam service.

3 Items 33d and 33e are not used when the Modulator Assembly is installed for a 49MV07.

## Description

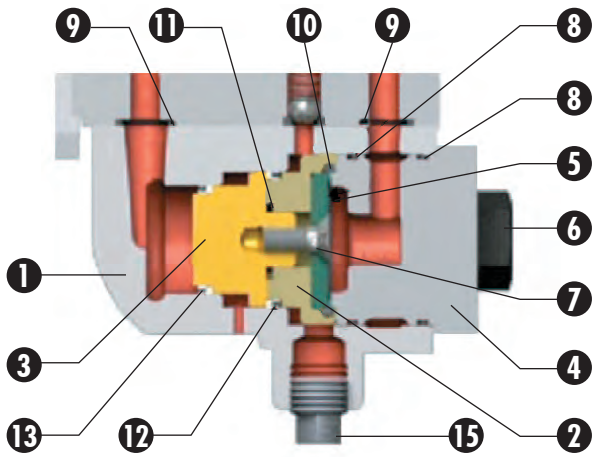

**Modulator Assembly  
For 49MV07**

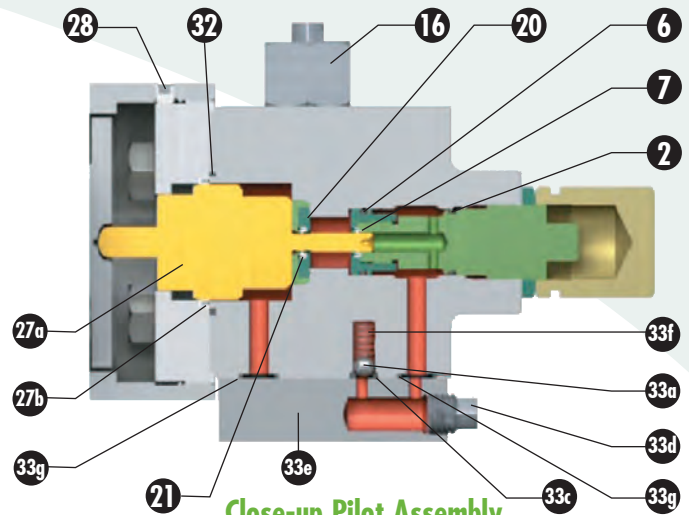

**Close-up Pilot Assembly  
49PV07 and 49MV07<sup>Note: 3</sup>**

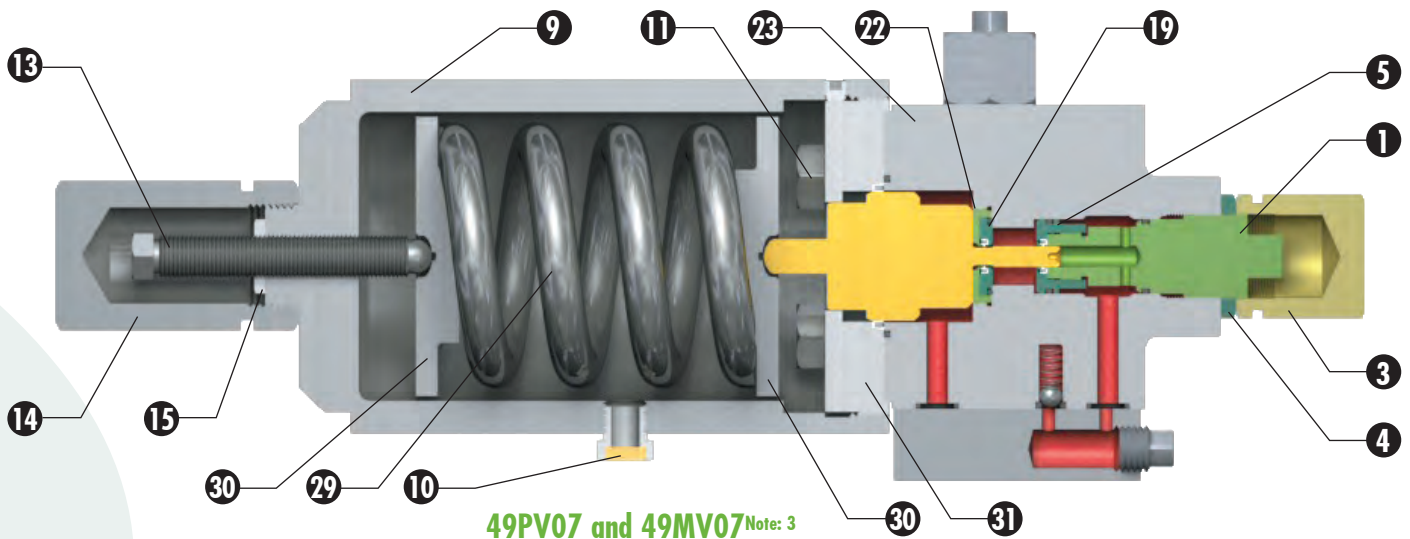

**49PV07 and 49MV07<sup>Note: 3</sup>**

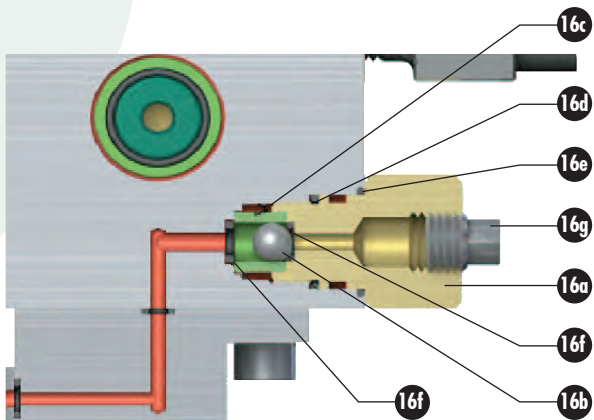

**16 Field Test Connection Assembly**

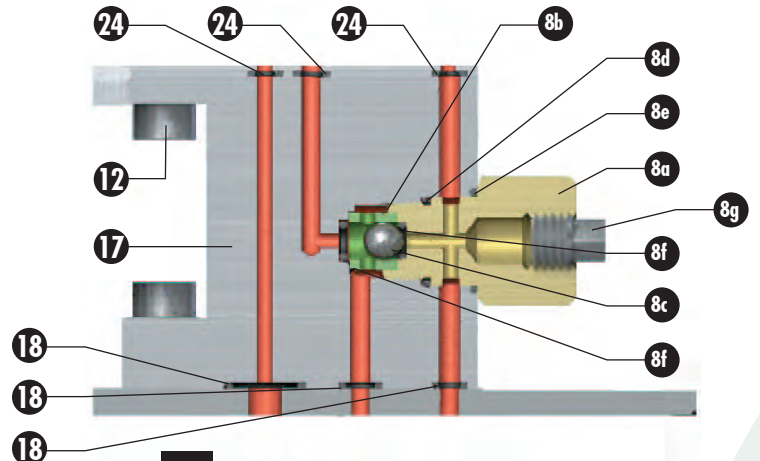

**8 Backflow Preventer Assembly**

**4900 Series Type  
49MV22 & 49MV72 Pilot**  
Modulating Action, Non-Flowing For Set Pressures 751 psig to 7200 psig



**49MV22  
49MV72 Modulating Action**

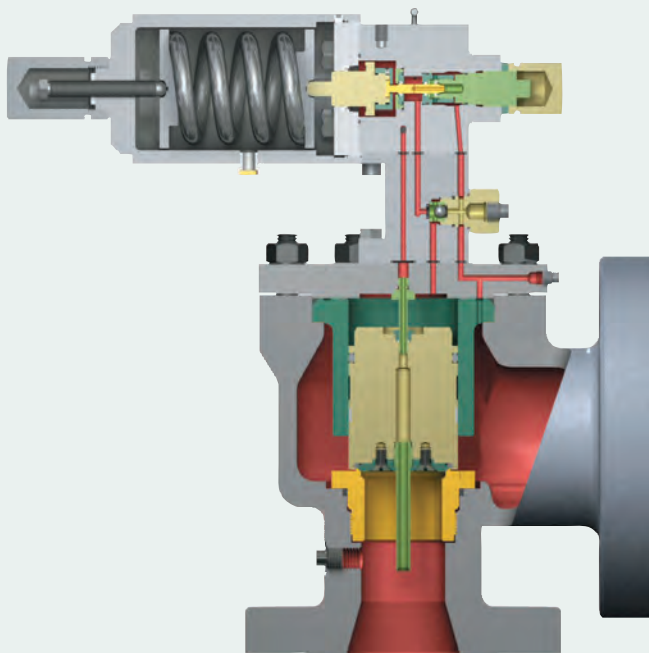

<b>Modulating Action</b> <sup>NOTE: 1</sup>		
	<b>Part</b>	<b>Material</b>
1	Adjuster Bottom	316 SS
2	O-Ring (Adjuster Bottom)	Select
3	Adjuster Cap	316 SS
4	Adjuster Lock Nut	316 SS
5	Adjuster Top	316 SS
6	O-Ring (Adjuster Top)	Select
7	Spring Seal (Adjuster Top)	Teflon®
8	Backflow Preventer Assembly	-
a	Backflow Preventer Body	316 SS
b	Backflow Preventer Guide	316 SS
c	Ball	316 SS
d	O-Ring (Backflow Preventer Body) Small	Select
e	O-Ring (Backflow Preventer Body) Large	Select
f	O-Ring (Ball Seat) (2)	Select
g	Pipe Plug	316 SS
9	Bonnet	SA351 Grade CF8M SS
10	Breather Filter Vent (Bonnet)	Bronze/Steel
11	Cap Screw (Top Plate) (4)	316 SS
12	Cap Screw (Inlet Adaptor) (8)	316 SS
13	Compression Screw	316 SS
14	Compression Screw Cap	316 SS
15	Compression Screw Lock Nut	316 SS
16	Field Test Connection Assembly	-
a	Field Test Body	316 SS
b	Ball	316 SS
c	Tube Filter	316 SS
d	O-Ring (Field Test Body) Small	Select
e	O-Ring (Field Test Body) Large	Select
f	O-Ring (Ball Seat) (2)	Select
g	Pipe Plug	316 SS
17	Inlet Adaptor	316 SS
18	O-Ring (Inlet Adaptor) 3 Sizes	Select
19	Insert Bottom	316 SS
20	O-Ring (insert)	Select
21	Spring Seal (Insert)	Teflon®
22	Insert Top	316 SS
23	Main Base	316 SS
24	O-Ring (Main Base) (3)	Select
25	Needle Valve (Manual Blowdown)	316 SS
26	Pipe Plug (not shown)	316 SS
27	Piston Assembly	-
a	Main Piston	316 SS
b	Spring Seal (Main Piston)	Teflon®
c	Piston Nut	316 SS
d	Piston Nose	Inconel X750
e	Set Screw (Piston Nut)	316 SS
28	Set Screw (Bonnet)	316 SS
29	Spring (Phosphated) <sup>NOTE: 2</sup>	Chrome Steel
30	Spring Washer (2)	316 SS
31	Top Plate	316 SS
32	O-Ring (Top Plate)	Select
33	Vent Seat Adaptor	316 SS
34	Spring Seal (Vent Seat Adaptor)	Teflon®

NOTE: 1 Pilot assemblies can be provided in special materials. Contact the factory for availability.  
2 49MV22 Dual Springs 2751-3750 PSIG. 49MV72 Dual Springs 5501-7200 PSIG.

## Description

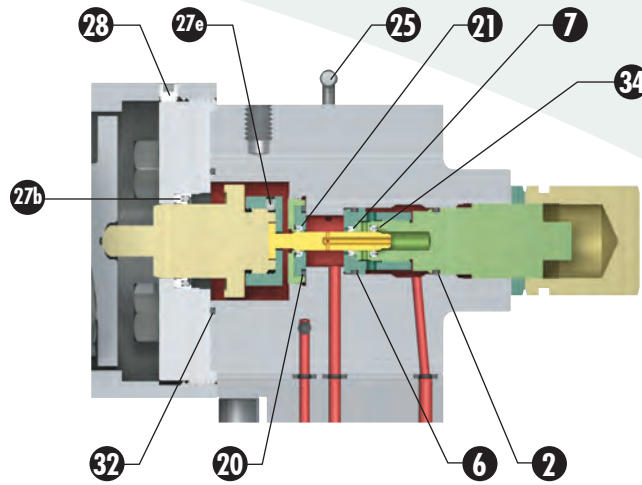

**Close-up Pilot Assembly**

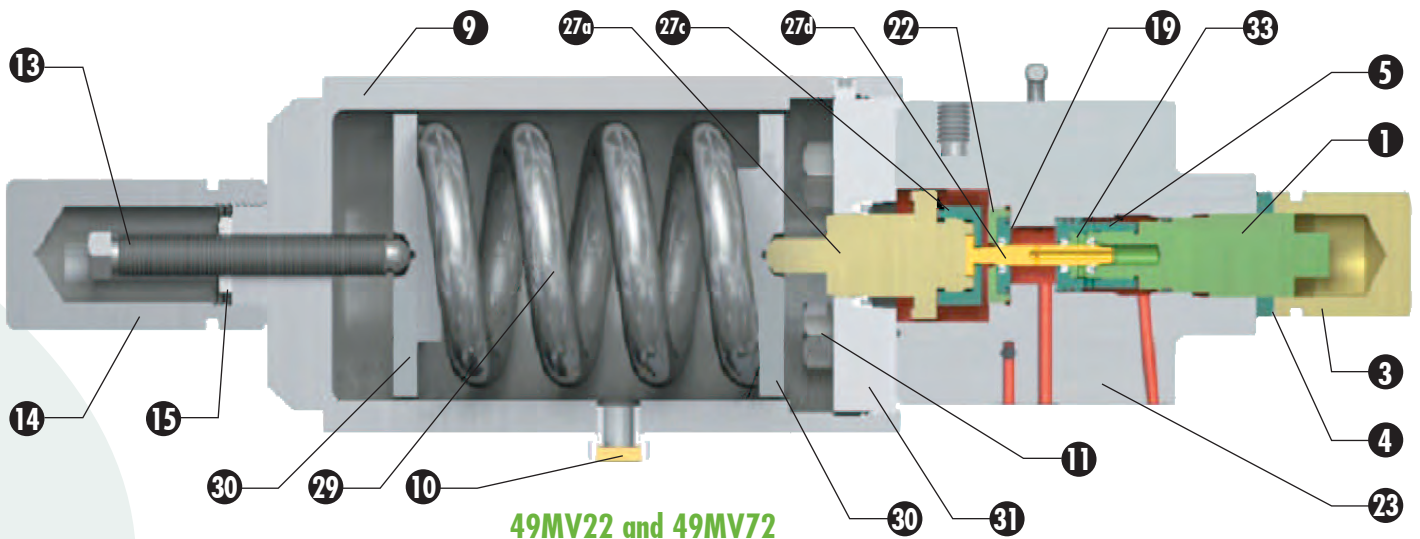

**49MV22 and 49MV72**

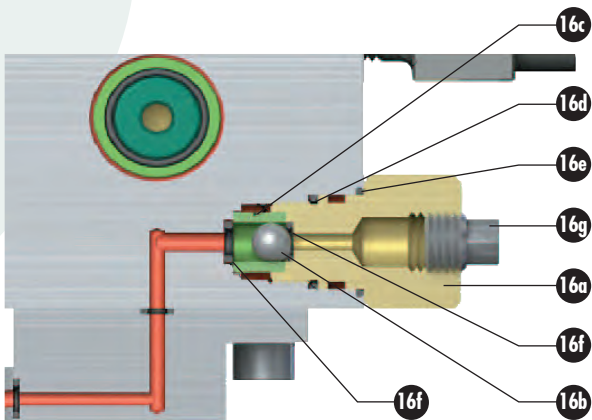

**16 Field Test Connection Assembly**

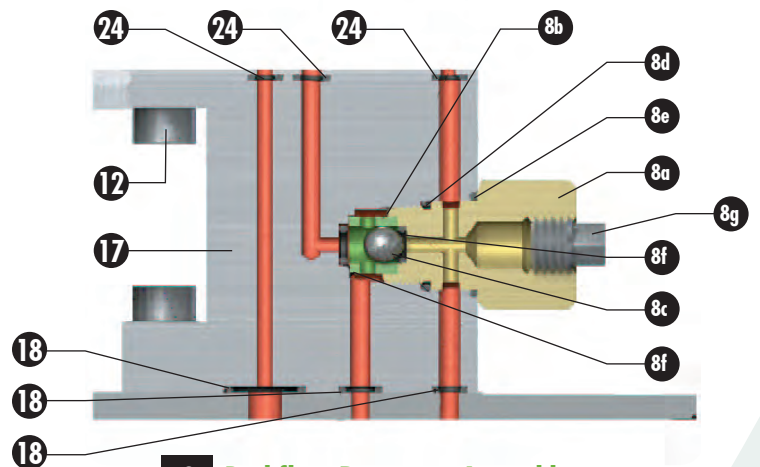

**8 Backflow Preventer Assembly**

## Standard Accessories

### Manual Blowdown Valve

A manual blowdown valve is supplied as standard for relieving the pilot operated safety relief valve. The blowdown valve is ported directly to the main dome area, so that the media in the dome is vented when the blowdown valve is actuated, thus allowing the main valve to open.

For all applications on air, water over 140°F, or steam service, ASME Section VIII-Division 1 requires each pressure relief valve to have a lifting device. This can be a blowdown valve or other means of connecting or applying pressure to the pilot to verify that the moving parts essential to good operation are free to move. (Reference: UG 136(a)(3)).

The lifting lever or blowdown valve may be omitted under Code Case 2203. All orders for pressure relief valves that are without levers or blowdown valves for steam, air and water over 140°F must state specifically that the valves are being purchased per Code Case 2203. The purchaser is responsible for obtaining jurisdictional authorization for use of Code Case 2203.

### Field Test Connection

A 1/4" FNPT field test connection is standard on all pilot valve types. This allows the stroking of the valve with an auxiliary media, e.g. air or nitrogen. An internal check valve is present in the field test connection isolating the inlet media from the test media and at the same time, allowing the valve to open normally in the event of a system over-pressurization during a field test.

### Filter - In Body

For all your applications, a 100-micron in-body filter is standard. These filters are installed in the body of the field test connection and are easily replaceable. The pilot valve body is made of 316 stainless steel with the replaceable stainless steel filter element. O-rings in the field test connection are selected for the service condition.

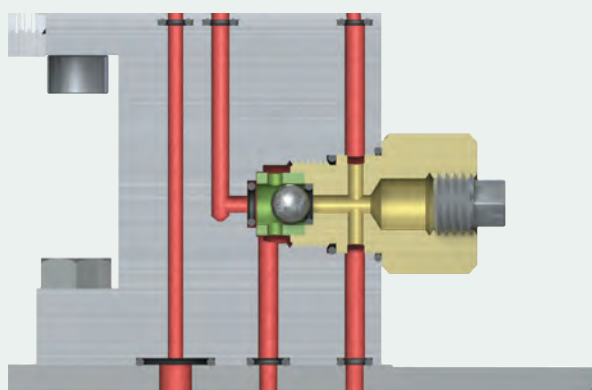

Backflow Preventer

### Backflow Preventer

When the pilot operated safety relief valve is not vented directly to atmosphere, it is possible to build up backpressure in the discharge line. This is typical in situations where several valves manifold into a common discharge header. Should the discharge line pressure exceed the valve inlet pressure, it could cause the disc to lift and allow reverse flow through the main valve. This potential situation will be eliminated through the use of the Backflow Preventer that is standard when a 4900 MPV is purchased.

### Bonnet

A vented bonnet with a breather filter vent provides protection of personnel. The bonnet and breather filter will protect the spring from external debris and weather conditions.

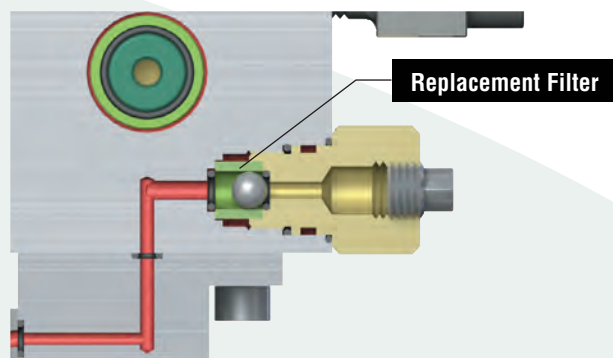

Field Test Connection

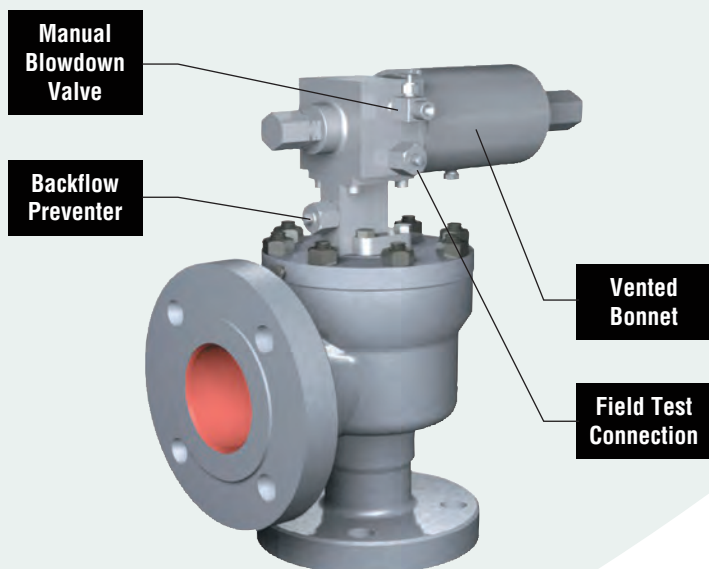

## Optional Accessories

### Pressure Differential Switch

#### (Tubing and Fittings Required)

**Electrical:** A pressure differential switch is available which may be wired to an operator station or some other remote location. The switch will provide a signal that indicates when the main valve is opening. The standard pressure differential switch is a single pole, double throw, rated at 5 amps and 30 volts DC with a NEMA 4 enclosure. (For other configurations, consult the factory.) **Pneumatic:** For applications that do not permit an electrical differential switch, an option is available to provide pneumatic signal to indicate when the main valve opens.

### Pneumatic or Electrical Blowdown

Consult the factory for applications that require a pneumatic or electrical solenoid blowdown valve for remote actuation from a distant location, such as an operator station.

### Remote Sensing

The pilot valve inlet may be piped to a location remote from the main valve at the pressure vessel or equipment being protected. Remote sensing can minimize the effects of excessive inlet pressure loss. For tubing size and maximum length, provide the factory with the information located on page 2900.25.

### Filter Options - Canister (Special Inlet Adaptor Required)

High capacity filters come in four variations: (1) Carbon steel cadmium coated filter body, (2) Stainless steel filter body, (3) Carbon steel cadmium coated filter body with stainless steel needle valve and (4) Stainless steel filter body with stainless steel needle valve.

All four variations have a 35-micron stainless steel element. The standard O-ring in the filter is Viton. The O-Ring in the filters for steam service will be Teflon®. The needle valve provided in variation (3) & (4) is manually operated and allows for purging the filtered material while the valve remains in operation.

All filter elements are stainless steel, and all filters, including carbon steel, conform to NACE Standard MR0175.

A canister filter is recommended for use on steam service.

### Pilot Valve Tester

The pilot valve test indicator is available for the modulating and pop-action pilot valves. The valve test indicator measures the set pressure of the pilot, while maintaining pressure on the main valve dome area; thereby, allowing only the pilot to actuate. The system shown below is available for remote or local testing.



Pilot Valve Tester

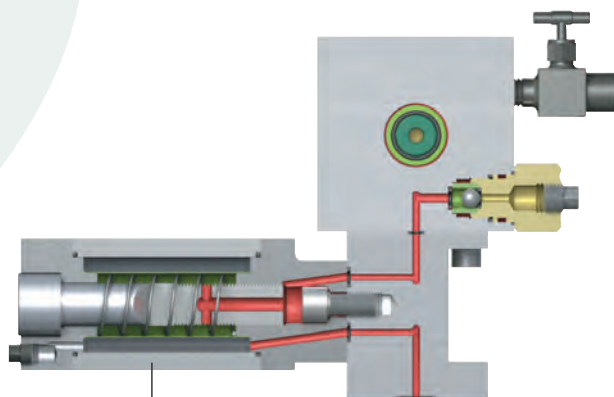

Internal View High Capacity Canister Filter

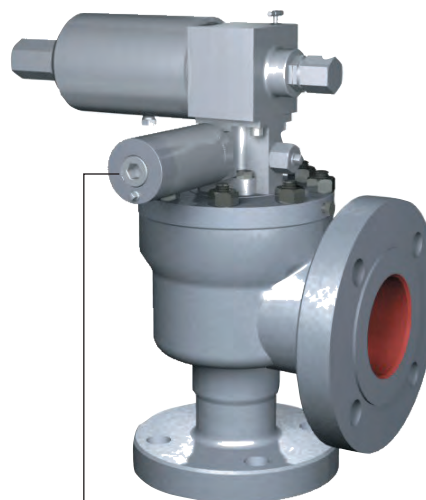

High Capacity Canister Filter

Series 4905 - 4918  
Standard Bore - Orifice Capacities - ASME SECTION VIII  
(USCS Units)

Capacities are based on set pressure plus 10%  
or 3 psi overpressure, whichever is greater.  
Capacities are in pounds per hour saturated steam.

Set Press. (psig)	Orifice Area (Sq. in.)													
	D 0.1314	E 0.228	F 0.359	G 0.594	H 0.930	J 1.513	K 2.160	L 3.350	M 4.229	N 5.098	P 7.491	Q 12.979	R 18.783	T 30.542
15	194	337	530	878	1375	2237	3193	4953	6252	7537	11076	19190	27772	45159
20	223	388	611	1012	1585	2579	3682	5710	7209	8690	12769	22125	32019	52064
30	283	491	774	1281	2005	3263	4658	7225	9121	10995	16156	27993	40512	65874
40	348	605	952	1576	2468	4015	5733	8891	11224	13531	19882	34449	49854	81065
50	414	718	1131	1872	2931	4768	6807	10557	13328	16066	23608	40904	59196	96256
60	479	831	1309	2167	3393	5520	7881	12224	15431	18602	27334	47360	68539	111448
70	544	945	1488	2462	3856	6273	8956	13890	17535	21138	31060	53816	77881	126639
80	610	1058	1667	2758	4318	7026	10030	15556	19638	23674	34786	60271	87224	141830
90	675	1172	1845	3053	4781	7778	11104	17222	21742	26209	38512	66727	96566	157021
100	740	1285	2024	3349	5243	8531	12179	18889	23845	28745	42238	73182	105909	172212
120	871	1512	2381	3940	6169	10036	14328	22221	28052	33816	49690	86094	124593	202595
140	1002	1739	2738	4531	7094	11541	16476	25554	32259	38888	57142	99005	143278	232977
160	1133	1966	3095	5121	8019	13046	18625	28886	36466	43959	64594	111916	161963	263360
180	1263	2192	3452	5712	8944	14551	20774	32219	40673	49030	72045	124827	180648	293742
200	1394	2419	3809	6303	9869	16056	22922	35551	44879	54102	79497	137738	199333	324124
220	1525	2646	4166	6894	10794	17561	25071	38884	49086	59173	86949	150649	218018	354507
240	1655	2873	4524	7485	11719	19066	27220	42216	53293	64244	94401	163561	236702	384889
260	1786	3100	4881	8076	12644	20571	29368	45549	57500	69316	101853	176472	255387	415271
280	1917	3326	5238	8667	13570	22076	31517	48881	61707	74387	109305	189383	274072	445654
300	2048	3553	5595	9258	14495	23582	33666	52214	65914	79458	116756	202294	292757	476036
320	2178	3780	5952	9849	15420	25087	35815	55546	70121	84530	124208	215205	311442	506419
340	2309	4007	6309	10440	16345	26592	37963	58879	74328	89601	131660	228116	330127	536801
360	2440	4234	6666	11030	17270	28097	40112	62211	78535	94673	139112	241028	348811	567183
380	2570	4460	7023	11621	18195	29602	42261	65544	82742	99744	146564	253939	367496	597566
400	2701	4687	7381	12212	19120	31107	44409	68876	86948	104815	154016	266850	386181	627948
420	2832	4914	7738	12803	20046	32612	46558	72209	91155	109887	161468	279761	404866	658331
440	2963	5141	8095	13394	20971	34117	48707	75541	95362	114958	168919	292672	423551	688713
460	3093	5368	8452	13985	21896	35622	50856	78874	99569	120029	176371	305583	442236	719095
480	3224	5594	8809	14576	22821	37127	53004	82206	103776	125101	183823	318495	460921	749478
500	3355	5821	9166	15167	23746	38633	55153	85539	107983	130172	191275	331406	479605	779860
520	3485	6048	9523	15758	24671	40138	57302	88871	112190	135243	198727	344317	498290	810243
540	3616	6275	9880	16349	25596	41643	59450	92204	116397	140315	206179	357228	516975	840625
560	3747	6502	10238	16939	26522	43148	61599	95536	120604	145386	213631	370139	535660	871077
580	3878	6728	10595	17530	27447	44653	63748	98869	124811	150457	221082	383050	554345	901390
600	4008	6955	10952	18121	28372	46158	65897	102201	129017	155529	228534	395962	573030	931772
620	4139	7182	11309	18712	29297	47663	68045	105533	133224	160600	235986	408873	591714	962154
640	4270	7409	11666	19303	30222	49168	70194	108866	137431	165672	243438	421784	610399	992537
660	4400	7636	12023	19894	31147	50673	72343	112198	141638	170743	250890	434695	629084	1022919
680	4531	7863	12380	20485	32072	52178	74491	115531	145845	175814	258342	447606	647769	1053302
700	4662	8089	12737	21076	32998	53683	76640	118863	150052	180886	265794	460518	666454	1083684
720	4793	8316	13095	21667	33923	55189	78789	122196	154259	185957	273245	473429	685139	1114066
740	4923	8543	13452	22257	34848	56694	80938	125528	158466	191028	280697	486340	703823	1144449
750	4989	8656	13630	22553	35310	57446	82012	127195	160569	193564	284423	492795	713166	1159640

APPROVED: ASME Boiler & Pressure Vessel Code, Section VIII (for set pressure 15 psig and above).  
CERTIFIED: National Board of Boiler and Pressure Vessel Inspectors.

Series 4905 - 4918  
Standard Bore - Orifice Capacities - ASME SECTION VIII  
(USCS Units)

Capacities are based on set pressure plus 10%  
or 3 psi overpressure, whichever is greater.  
Capacities are in standard cubic feet per minute @ 60°F.

Orifice Area (Sq. in.)

Set Press. (psig)	Orifice Area (Sq. in.)													
	D 0.1314	E 0.228	F 0.359	G 0.594	H 0.930	J 1.513	K 2.160	L 3.350	M 4.229	N 5.098	P 7.491	Q 12.979	R 18.783	T 30.542
15	69	119	188	312	489	796	1136	1763	2225	2683	3942	6830	9885	16074
20	79	138	217	360	564	918	1310	2032	2566	3093	4545	7875	11396	18531
30	100	175	275	456	713	1161	1658	2571	3246	3913	5750	9964	14419	23447
40	124	215	339	561	878	1429	2040	3164	3995	4816	7077	12261	17745	28854
50	147	255	402	666	1043	1697	2423	3758	4744	5718	8403	14559	21070	34261
60	170	296	466	771	1207	1965	2805	4351	5492	6621	9729	16857	24396	39669
70	193	336	529	876	1372	2233	3187	4944	6241	7524	11055	19155	27721	45076
80	217	376	593	981	1537	2500	3570	5537	6990	8426	12382	21453	31046	50483
90	240	417	656	1086	1701	2768	3952	6130	7738	9329	13708	23751	34372	55890
100	263	457	720	1192	1866	3036	4335	6723	8487	10231	15034	26048	37697	61297
120	310	538	847	1402	2195	3572	5099	7909	9985	12036	17686	30644	44348	72112
140	356	619	974	1612	2525	4108	5864	9095	11482	13841	20339	35240	50998	82926
160	403	699	1101	1823	2854	4643	6629	10281	12979	15647	22991	39835	57649	93740
180	449	780	1228	2033	3183	5179	7394	11468	14477	17452	25644	44431	64300	104555
200	496	861	1356	2243	3512	5715	8159	12654	15974	19257	28296	49026	70951	115369
220	542	941	1483	2454	3842	6250	8924	13840	17472	21062	30948	53622	77601	126183
240	589	1022	1610	2664	4171	6786	9688	15026	18969	22867	33601	58218	84252	136998
260	635	1103	1737	2874	4500	7322	10453	16212	20466	24672	36253	62813	90903	147812
280	682	1184	1864	3085	4830	7858	11218	17399	21964	26477	38906	67409	97553	158627
300	728	1264	1991	3295	5159	8393	11983	18585	23461	28282	41558	72005	104204	169441
320	775	1345	2118	3505	5488	8929	12748	19771	24959	30087	44211	76600	110855	180255
340	822	1426	2245	3716	5818	9465	13512	20957	26456	31892	46863	81196	117506	191070
360	868	1507	2373	3926	6147	10001	14277	22143	27953	33698	49515	85791	124156	201884
380	915	1587	2500	4136	6476	10536	15042	23329	29451	35503	52168	90387	130807	212698
400	961	1668	2627	4347	6805	11072	15807	24516	30948	37308	54820	94983	137458	223513
420	1008	1749	2754	4557	7135	11608	16572	25702	32446	39113	57473	99578	144108	234327
440	1054	1830	2881	4767	7464	12143	17336	26888	33943	40918	60125	104174	150759	245141
460	1101	1910	3008	4977	7793	12679	18101	28074	35440	42723	62778	108770	157410	255956
480	1147	1991	3135	5188	8123	13215	18866	29260	36938	44528	65430	113365	164061	266770
500	1194	2072	3262	5398	8452	13751	19631	30446	38435	46333	68082	117961	170711	277584
550	1310	2274	3580	5924	9275	15090	21543	33412	42179	50846	74713	129450	187338	304620
600	1426	2475	3898	6450	10098	16429	23455	36377	45922	55359	81345	140939	203965	331656
650	1543	2677	4216	6976	10922	17769	25367	39343	49666	59872	87976	152428	220592	358692
700	1659	2879	4533	7501	11745	19108	27279	42308	53409	64384	94607	163917	237218	385728
750	1775	3081	4851	8027	12568	20447	29191	45274	57153	68897	101238	175406	253845	412764
800	1892	3283	5169	8553	13391	21786	31103	48239	60896	73410	107869	186895	270472	439800
900	2124	3686	5805	9605	15038	24465	34927	54170	68384	82435	121131	209873	303726	493872
1000	2357	4090	6440	10656	16684	27144	38751	60101	75871	91461	134393	232851	336979	547943
1100	2590	4494	7076	11708	18331	29822	42575	66032	83358	100487	147655	255830	370233	602015
1200	2822	4897	7711	12760	19977	32501	46400	71962	90845	109512	160917	278808	403486	656087
1300	3055	5301	8347	13811	21624	35108	50224	77893	98332	118538	174179	301786	436740	710159
1400	3287	5705	8983	14863	23270	37858	54048	83824	105819	127563	187442	324764	469993	764231
1500	3520	6108	9618	15914	24917	40537	57872	89755	113306	136589	200704	347742	503247	818302
1600	3753	6512	10254	16966	26563	43215	61696	95686	120793	145614	213966	370720	536501	872374
1700	3985	6916	10889	18018	28210	45894	65520	101617	128280	154640	227228	393698	569754	926446
1800	4218	7319	11525	19069	29856	48573	69344	107548	135767	163665	240490	416676	603008	980518
1900	4451	7723	12160	20121	31503	51251	73168	113479	143254	172691	253752	439655	636261	1034590
2000	4683	8127	12796	21172	33149	53930	76992	119409	150741	181716	267014	462633	669515	1088661
2500	5846	10145	15974	26431	41382	67323	96113	149064	188176	226844	333325	577523	835783	1359020
3000	7010	12163	19152	31689	49614	80716	115233	178718	225612	271972	399636	692414	1002051	1629379
3500	8173	14181	22330	36947	57846	94109	134353	208372	263047	317100	465946	807305	1168318	1899738
4000	9336	16200	25507	42205	66079	107503	153474	238027	300482	362227	532257	922195	1334586	2170097
4500	10499	18218	28685	47463	74311	120896	172594	267681	337918	407355	598567	1037086	1500854	2440456
5000	11662	20236	31863	52721	82544	134289	191715	297335	375353	452483	664878	1151976	1667122	2710815
5500	12825	22254	35041	57979	90776	147682	210835	326990	412788	497610	731189	1266867	1833390	2981174
6000	13988	24273	38219	63237	99008	161075	229955	356644	450223	542738	797499	1381758	1999658	3251533
6500	15152	26291	41397	68495	107241	174468	249076	386298	487659	587866	863810	1496648	2165926	3521892
7000	16315	28309	44575	73754	115473	187861	268196	415953	525094	632993	930121	1611539	2332194	3792251
7500	17478	30327	47753	79012	123705	201255	287317	445607	562529	678121	996431	1726430	2498461	4062610

APPROVED: ASME Boiler & Pressure Vessel Code, Section VIII (for set pressure 15 psig and above). CERTIFIED: National Board of Boiler and Pressure Vessel Inspectors.

**Series 4905 - 4918**  
**Standard Bore - Orifice Capacities - ASME SECTION VIII**  
**(USCS Units)**

Capacities are based on set pressure plus 10% or 3 psi overpressure, whichever is greater. Capacities are in gallons of water per minute @ 70°F and 0 psig backpressure.

**Orifice Area (Sq. in.)**

Set Press. (psig)	Orifice Area (Sq. in.)													
	D 0.1314	E 0.228	F 0.359	G 0.594	H 0.930	J 1.513	K 2.160	L 3.350	M 4.229	N 5.098	P 7.491	Q 12.979	R 18.783	T 30.542
15	16	27	43	72	113	185	264	410	518	624	917	1590	2301	3742
20	18	31	49	82	128	209	299	463	585	706	1037	1797	2601	4230
30	21	37	59	98	154	251	358	555	701	845	1242	2153	3116	5066
40	25	43	68	113	178	289	413	641	810	976	1434	2486	3598	5850
50	28	48	76	127	199	324	462	717	905	1091	1604	2779	4022	6541
60	30	53	84	139	218	354	506	785	992	1196	1757	3045	4406	7165
70	33	57	90	150	235	383	547	848	1071	1291	1898	3289	4759	7739
80	35	61	97	160	251	409	585	907	1145	1381	2029	3516	5088	8274
90	37	65	103	170	267	434	620	962	1215	1464	2152	3729	5397	8776
100	39	69	108	179	281	458	654	1014	1280	1544	2268	3931	5689	9250
120	43	75	119	197	308	502	716	1111	1403	1691	2485	4306	6232	10133
140	47	81	128	212	333	542	774	1200	1515	1827	2684	4651	6731	10945
160	50	87	137	227	356	579	827	1283	1620	1953	2869	4972	7196	11701
180	53	92	145	241	377	614	877	1361	1718	2071	3044	5274	7632	12411
200	56	97	153	254	398	648	925	1434	1811	2183	3208	5559	8045	13082
220	59	102	161	266	417	679	970	1504	1899	2290	3365	5830	8438	13721
240	61	106	168	278	436	709	1013	1571	1984	2392	3515	6090	8813	14331
260	64	111	175	290	454	738	1054	1636	2065	2489	3658	6338	9173	14916
280	66	115	181	301	471	766	1094	1697	2143	2583	3796	6578	9519	15479
300	68	119	188	311	487	793	1133	1757	2218	2674	3929	6808	9853	16022
320	71	123	194	321	503	819	1170	1815	2291	2762	4058	7032	10177	16548
340	73	127	200	331	519	845	1206	1870	2361	2847	4183	7248	10490	17057
360	75	131	206	341	534	869	1241	1925	2430	2929	4304	7458	10794	17552
380	77	134	211	350	549	893	1275	1977	2496	3010	4422	7663	11090	18033
400	79	138	217	359	563	916	1308	2029	2561	3088	4537	7862	11378	18501
420	81	141	222	368	577	939	1340	2079	2625	3164	4649	8056	11659	18958
440	83	144	228	377	590	961	1372	2128	2686	3238	4759	8246	11933	19404
460	85	148	233	385	604	982	1403	2176	2747	3311	4866	8431	12201	19840
480	87	151	238	394	617	1004	1433	2223	2806	3382	4970	8612	12464	20267
500	88	154	243	402	629	1024	1462	2268	2864	3452	5073	8790	12721	20685
550	93	161	255	421	660	1074	1534	2379	3003	3621	5321	9219	13342	21694
600	97	169	266	440	689	1122	1602	2485	3137	3782	5557	9629	13935	22659
650	101	176	277	458	718	1168	1667	2586	3265	3936	5784	10022	14504	23584
700	105	182	287	476	745	1212	1730	2684	3388	4085	6003	10400	15052	24475
750	108	189	297	492	771	1255	1791	2778	3507	4228	6213	10765	15580	25334
800	112	195	307	508	796	1296	1850	2869	3622	4367	6417	11119	16091	26165
900	119	207	326	539	845	1374	1962	3044	3842	4632	6806	11793	17067	27752
1000	125	218	343	568	890	1449	2068	3208	4050	4882	7174	12431	17990	29253
1100	131	229	360	596	934	1519	2169	3365	4248	5121	7525	13038	18868	30681
1200	137	239	376	623	975	1587	2266	3514	4437	5348	7859	13617	19707	32045
1300	143	248	392	648	1015	1652	2358	3658	4618	5567	8180	14174	20512	33354
1400	148	258	406	673	1053	1714	2447	3796	4792	5777	8489	14709	21286	34613
1500	154	267	421	696	1090	1774	2533	3929	4960	5980	8787	15225	22033	35828
1600	159	276	434	719	1126	1833	2616	4058	5123	6176	9075	15724	22756	37003
1700	164	284	448	741	1161	1889	2697	4183	5281	6366	9355	16208	23456	38141
1800	168	292	461	763	1195	1944	2775	4304	5434	6551	9626	16678	24136	39247
1900	173	301	473	784	1227	1997	2851	4422	5583	6730	9890	17135	24798	40323
2000	177	308	486	804	1259	2049	2925	4537	5728	6905	10146	17580	25442	41370
2500	198	345	543	899	1408	2291	3271	5073	6404	7720	11344	19655	28445	46253
3000	217	378	595	985	1542	2510	3583	5557	7015	8457	12427	21531	31160	50668
3500	235	408	643	1064	1666	2711	3870	6002	7577	9135	13423	23257	33657	54728
4000	251	436	687	1137	1781	2898	4137	6417	8101	9765	14349	24862	35981	58506
4500	266	463	729	1206	1889	3074	4388	6806	8592	10358	15220	26371	38163	62056
5000	281	488	768	1272	1991	3240	4626	7174	9057	10918	16043	27797	40228	65412
5500	295	512	806	1334	2089	3398	4851	7524	9499	11451	16826	29154	42191	68605
6000	308	534	842	1393	2181	3549	5067	7859	9921	11960	17575	30450	44067	71656
6500	320	556	876	1450	2271	3694	5274	8180	10327	12449	18292	31694	45867	74582
7000	332	577	909	1505	2356	3834	5473	8489	10716	12919	18983	32890	47598	77397
7500	344	598	941	1558	2439	3968	5665	8787	11092	13372	19649	34044	49269	80113

APPROVED: ASME Boiler & Pressure Vessel Code, Section VIII (for set pressure 15 psig and above). CERTIFIED: National Board of Boiler and Pressure Vessel Inspectors.