

19000

Safety Relief Valve



Table of Contents

Introduction	19000.2
19000 Scope of Design	19000.3
Materials	19000.5
19000 DA (Soft Seat)	19000.7
19000 MBP (Back Pressure Compensation)	19000.9
Corrosive Service Material Selection	19000.11
Dimensions & Weights	19000.15
Threaded Connections	19000.15
Socket Weld Connections	19000.17
Flanged Connections	19000.19
Pressure Temperature Limits	19000.23
O-Ring Selection Procedure	19000.23
Pressure Temperature Ratings	19000.24
Capacities	19000.26
Air	19000.26
Steam	19000.27
Water	19000.28

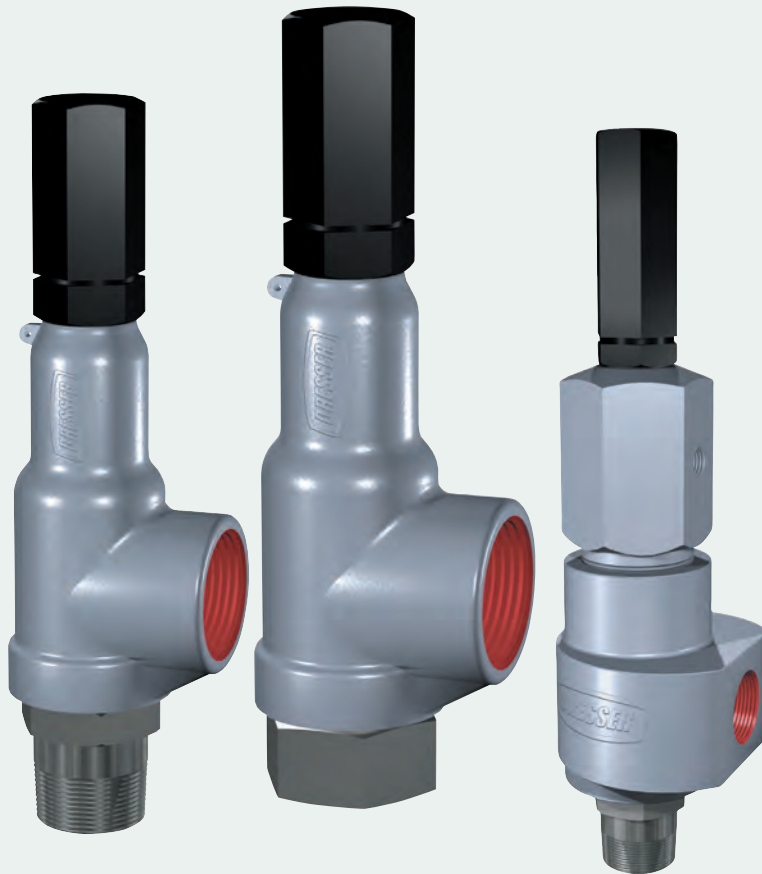

19000 Series Threaded Safety Relief Valve

Introduction

The 19000 Series valves are designed and manufactured in compliance with ASME B & PVC, Section VIII and Section III (Class I, II and III) as well as being CE compliant to the European Pressure Equipment Directive 97/23/EC. Seat tightness, blowdown and capacity on all types of media meets the industry needs for overpressure protection in chemical, petrochemical, refinery, power generation (nuclear and conventional) and other commercial applications.

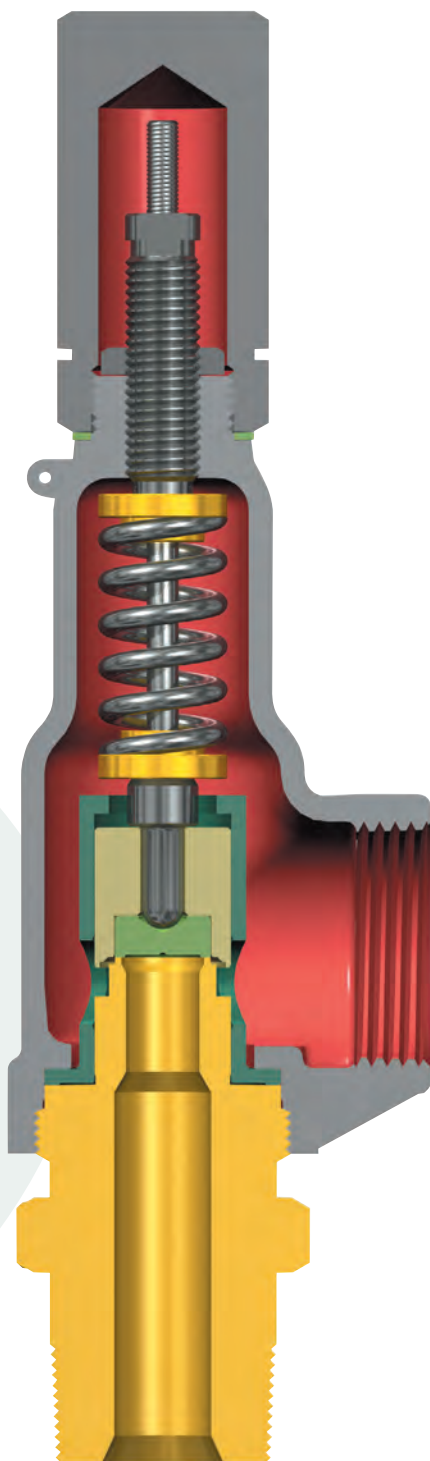

19000-2

Valve Closed

General Information

The 19000 Series threaded safety relief valve has 316 stainless steel trim as standard material. Reliable performance and easy maintenance procedures are characteristics of this valve (when properly installed in suitable applications for its design).

The 19000 Series valves has three pressure classes, 19000L (5 through 290 psig), 19000M (291 through 2000 psig), and 19000H (2001 psig and up). Standard 19000 parts are used for both liquid applications and gas applications. It is designed for short blowdown on all medias, typically less than 10%.

All 19000 Series valves have fixed blowdown. This means that the parts are designed so that there is no blowdown adjustment required when setting or testing the valve.

Design Options

a. O-Ring seat seal valves

All 19000 Series valves are available with an O-Ring seat seal, as a design option. This optional design provides a bubble tightness in excess of 97% of the valve set pressure, in order to meet application requirements beyond the normal capabilities of metal to metal seat valves. 19000 Series valves with the O-Ring seat seal option are identified by the suffix DA (e.g., 1-19096L-DA).

b. Lifting Levers, Caps and Gags

All 19000 Series valves are designed so that field conversion from the standard screwed cap to a plain lifting lever cap, or to a packed lifting lever cap (or vice versa) does not require valve assembly during resetting. The lifting lever option is designed to open the valve at 75% of the valve set pressure, in compliance with ASME B & PVC, Section VIII. Further, all available 19000 Series valve caps may be equipped with a gag, upon customer request.

c. Inlet/Outlet Connections

All 19000 Series valves can be provided by CONSOLIDATED with flanges, threaded or socket weld inlet/outlet connections upon customer request.

19000 Standard Valves

This product is normally supplied with threaded inlet and outlet connections. Socket weld or flanged end connections are available as well.

Product type designations change depending on connection sizes, orifice sizes, pressure range, and whether connections are male or female.

Unless otherwise specified, the valve is always supplied with a screwed cap. The exception to this would be where ASME requires levers for steam, air and water service over 140°F (60°C).

Springs of precipitation hardened stainless steel are specified for -75°F to 800°F (-59°C to 426.6°C) and the valves carry a "c" suffix in that case. Inconel springs are used for temperatures 801°F to 1100°F (427.2°C to 593.3°C) and the valve carries a "t" suffix.

When selecting valves for back pressure applications, the following limits apply.

- Constant back pressure: 400 psig maximum
- Variable back pressure (superimposed or built-up): 400 psig or 10% of set pressure whichever is smaller.

Product variations consist of:

- 19000SG - Sour Gas Trim
- 19000DA - Soft Seat
- 19000MBP - Back Pressure Compensation

Product material variations include:

- 316 Stainless Steel
- Monel
- Hastelloy
- Alloy 20

Pressure/Temperature ratings may vary from those for standard valves when other than standard materials are selected. Consult factory if you need assistance.

Orifice	Pressure Range (psig)	Standard Valve Type	Standard Connections (in.)
.096 Sq. in. 61.9 Sq. mm	5 to 290	1/2-19096L	1/2 - MNPT x 1 - FNPT
		3/4-19096L	3/4 - MNPT x 1 - FNPT 3/4 - FNPT x 1 - FNPT
		1-19096L	1 - MNPT x 1 - FNPT
	291 to 2000	1/2-19096M	1/2 - MNPT x 1 - FNPT
		3/4-19096M	3/4 - MNPT x 1 - FNPT 3/4 - FNPT x 1 - FNPT
		1-19096M	1 - MNPT x 1 - FNPT
2001 to 5000	3/4-19096H	3/4 - FNPT x 1 - FNPT	
.096 Sq. in. 61.9 Sq. mm	50 to 2000	1/2-19096MBP	1/2 - MNPT x 1 - FNPT
		3/4-19096MBP	3/4 - MNPT x 1 - FNPT
		1-19096MBP	1 - MNPT x 1 - FNPT
.110 Sq. in. 70.9 Sq. mm	5 to 290	1/2-19110L	1/2 - MNPT x 1 - FNPT
		3/4-19110L	3/4 - MNPT x 1 - FNPT 3/4 - FNPT x 1 - FNPT
		1-19110L	1 - MNPT x 1 - FNPT
	291 to 2000	1/2-19110M	1/2 - MNPT x 1 - FNPT
		3/4-19110M	3/4 - MNPT x 1 - FNPT 3/4 - FNPT x 1 - FNPT
		1-19110M	1 - MNPT x 1 - FNPT
2001 to 5000	3/4-19110H	3/4 - FNPT x 1 - FNPT	
.126 Sq. in. 81.3 Sq. mm	5 to 290	3/4-19126L	3/4 - MNPT x 1 - FNPT 3/4 - FNPT x 1 - FNPT
		1-19126L	1 - MNPT x 1 - FNPT
	291 to 2000	3/4-19126M	3/4 - MNPT x 1 - FNPT 3/4 - FNPT x 1 - FNPT
		1-19126M	1 - MNPT x 1 - FNPT
	2001 to 8000	3/4-19126H	3/4 - FNPT x 1 - FNPT
	.226 Sq. in. 145.8 Sq. mm	5 to 290	1-19226L
291 to 2000		1-19226M	1 - MNPT x 1-1/2 - FNPT 1 - FNPT x 1-1/2 - FNPT
		1-19226H	1 - FNPT x 1-1/2 - FNPT
2001 to 6400		1-19226H	1 - FNPT x 1-1/2 - FNPT
.357 Sq. in. 230.3 Sq. mm	5 to 290	1 1/2-19357L	1-1/2 - FNPT x 2 - FNPT
	291 to 1500	1 1/2-19357M	1-1/2 - FNPT x 2 - FNPT
.567 Sq. in. 365.8 Sq. mm	5 to 290	2-19567L	2 - FNPT x 2-1/2 - FNPT
	291 to 1000	2-19567M	2 - FNPT x 2-1/2 - FNPT

19000 Standard Valves

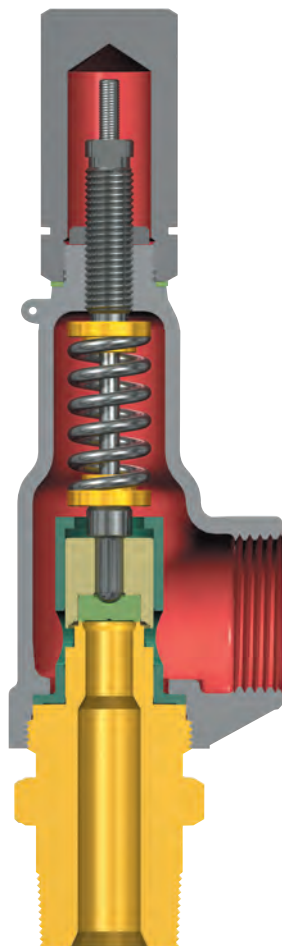

19000-2 Male NPT Inlet

19096L, 19110L, 19126L, 19226L,
19096M, 19110M, 19126M, 19226M

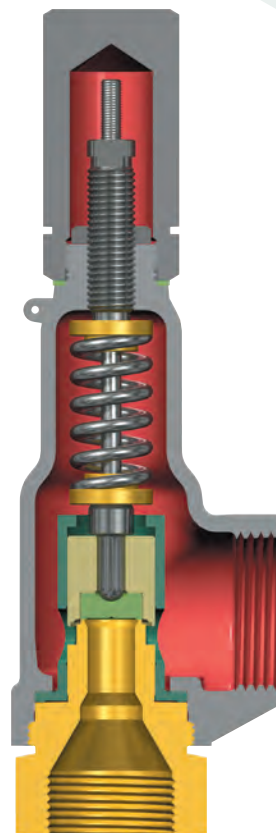

19000-2 Female NPT Inlet

19096L, 19110L, 19126L, 19226L, 19357L, 19567L,
19096M, 19110M, 19126M, 19226M, 19357M,
19567M, 19096H, 19110H, 19126H, 19226H

19000SG (Sour Gas)

The standard 19000 valve has component materials selected which comply with NACE MR0103-2003 requirements (except the valve spring).

To fully comply with MR0103-2003, utilize the standard valve and specify an Inconel X750 spring.

When service temperature exceeds 250°F an Inconel X750 disc will be the standard component material meeting the requirements of MR0103-2003. Under 250°F the standard component material for the disc is 316SS.

The Inconel X750 disc, Inconel disc holder, Stellite® faced base and Inconel spindle used in high pressure valves will meet the requirements of MR0103-2003 when supplied with an Inconel X750 spring.

19000 SG also has components which comply with NACE MR0175-2002 and prior editions. For compliance with NACE MR0175-2003, media and materials evaluation is required. Please contact factory sales.

Materials

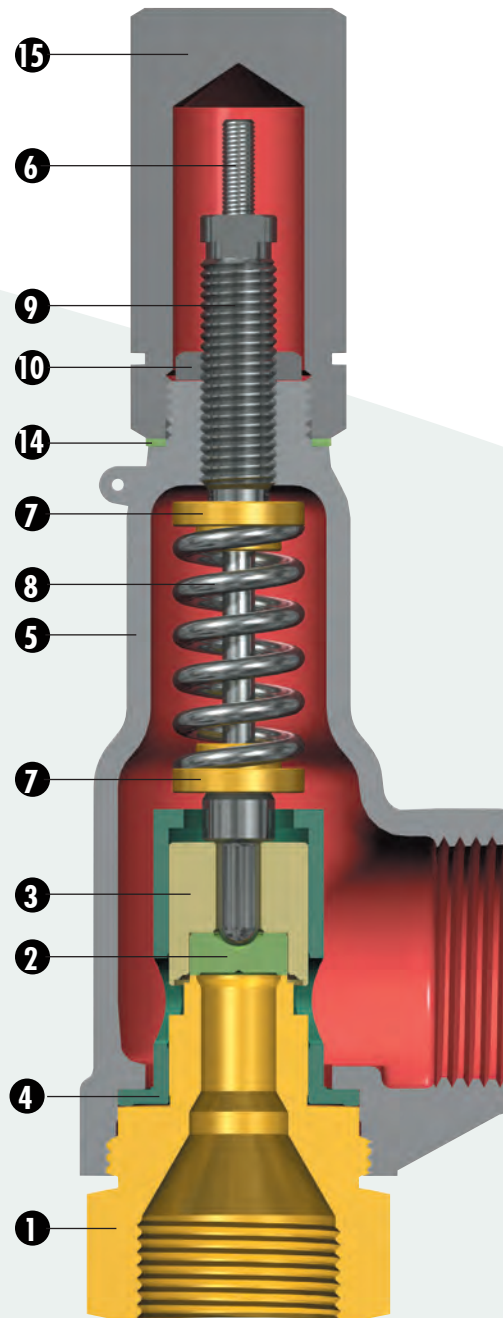

19000-2

Threaded End Connection

Extension, flange and nipples for flanged and socket-weld connections are not shown.

Materials

	Part	Material
1	Base L & M	316 SS
	Base H	316 SS/Stellite Hardfaced Seat
2	Disc L & M	316 SS
	Disc L & M (Steam)*	616 SS
	Disc H	Inconel X750
3	Disc Holder	316 SS
4	Guide	316 SS
5	Bonnet	SA216 WCC Carbon Steel (phosphated)
6	Spindle L & M	316 SS
	Spindle H	Inconel
7	Spring Washer	Carbon Steel (phosphated)
8	Spring 19000c	17-7 PH SS
	Spring 19000t	Inconel X750
9	Adjusting Screw	316 SS
10	Adjusting Screw Locknut	316 SS
11	Gag Bolt	Carbon Steel
12	Sealing Plug	Carbon Steel
13	Sealing Plug Gasket	Soft Iron
14	Cap Gasket	Soft Iron
15	Screwed Cap	Carbon Steel (phosphated)
16	Packed Cap	Carbon Steel (phosphated)
17	Cam Shaft	410 SS
18	Bushing	416 SS
19	Bushing Gasket	Soft Iron
20	Lever (Packed)	Malleable Iron
21	Drive Pin	Steel (Ni-Plated)
22	O-Ring	Viton 70
23	Release Nut	Carbon Steel
24	Release Lock Nut	Carbon Steel
25	Plain Lever Cap	Malleable Iron
26	Lifting Lever (Plain)	Malleable Iron
27	Cap Screw	Carbon Steel
28	Lever Pin	Carbon Steel

* Supplied for steam service above 251°F (121.7°C)

Sour Gas (SG) or NACE applications

The 19000 valve materials are standard except for the spring, which will be Inconel X750, and for service temperatures that exceed 250°F, an Inconel X750 disc will be provided.

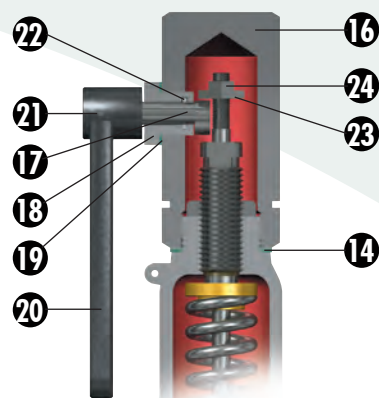

Packed Lever

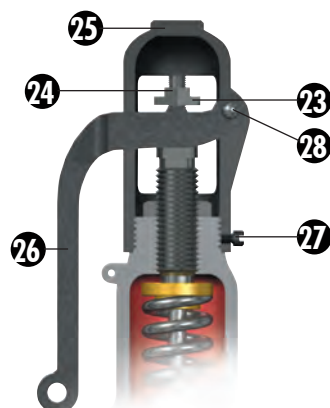

Plain Lever

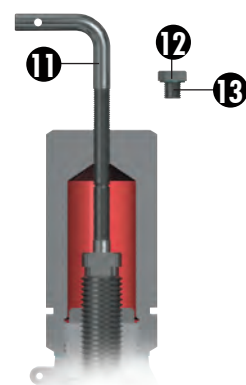

Cap with Gag

19000 Soft Seats (DA)

Tightness

CONSOLIDATED O-Ring seat valves are bubble tight at **97%** of set pressures over 100 psig.

Percent of set pressure (popping pressure) at which valve will be bubble tight on air.

Set Pressure (psig)	Percent of Set Pressure
5 to 30	90%
31 to 50	92%
51 to 100	94%
101 to Max rating of valve	97%

CONSOLIDATED O-Ring seat seals provide positive seat tightness at service pressures closer to the set pressure than is possible with metal-to-metal seats assuring continuous, trouble-free service, and complete valve closure after numerous "pops".

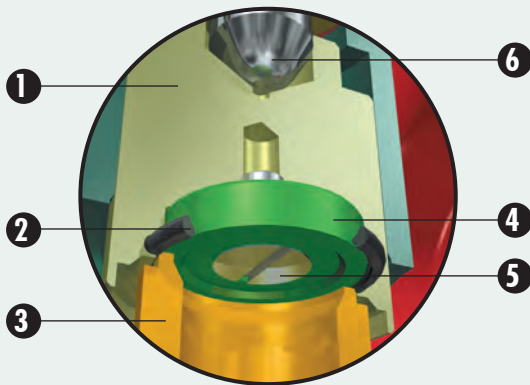

Soft Seat Material Temperature Limits (°F)

Material	Temperature Limits (°F)
Nitrile	-45 to +350°
Ethylene/Propylene	-70 to +500°
Fluoro-Carbon	-15 to +400°
Fluoro-Silicone	-100 to +350°
Neoprene	-45 to +300°
Silicone	-65 to +437°
Teflon	-300 to +505°

NOTE: Contact factory for other O-Ring materials and the respective temperature limitations.

Applications

The O-Ring design can be used for improved product performance in the same manner as that stated for the 1900 Flanged Series.

Features

- Leak tight seats
- Tight seats at high operating pressures
- Simple replacement of soft seat
- Large selection of soft seat materials
- Soft seats are in standard O-Ring sizes
- Proven seat design

Benefits

- Potential loss of system pressure and process media reduced
- Maximizes process efficiency and product output
- Reduces maintenance costs
- Suitable for varied process applications
- Replacement seats readily available
- Dependable performance

	Part	Material
1	Disc Holder 19000L Disc Holder 19000M & H	316 SS Inconel
2	O-Ring Seat Seal	Select
3	Base	316 SS
4	O-Ring Retainer 19000L & M O-Ring Retainer 19000H	316 SS Inconel X750
5	Retainer Lockscrew	316 SS
6	Spindle 19000L Spindle 19000M & H	316 SS Inconel

Sour Gas (SG) or NACE applications

The 19000(DA) valve materials are standard except for the spring which will be Inconel X750.

Operation and Performance

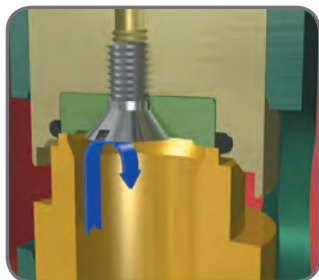

Valve in Closed Position

- 90% of set pressure
Metal seat contains media
No leakage - bubble tight

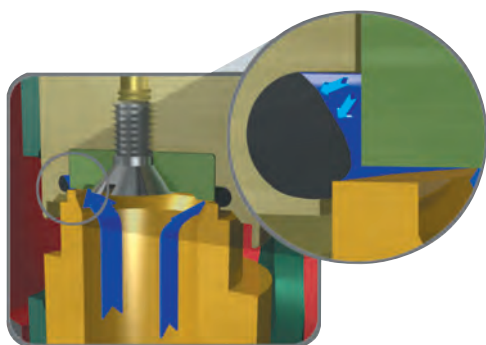

Valve at Greater than 90% of set pressure

- Metal seats separate
- System pressure acts on O-Ring, pressure forces the O-Ring against the lip of the nozzle and curved recess of the disc holder. As the pressure within the valves rises to the set point, the O-Ring is pressed tightly against the nozzle to maintain maximum sealing force until break-away pressure is reached.
- Bubble tight seat to **97%** of set pressure



Valve Flowing

- Full lift
- Flowing rated capacity
- O-Ring is protected from blowouts as the encapsulating retainer prevents the O-Ring from being pulled from its seat by the high velocity, low pressure discharge inside the valve.

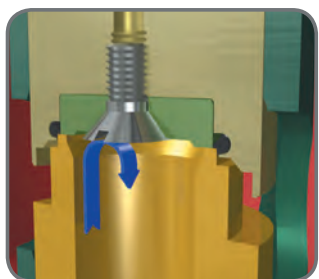

Valve Returns to Closed Position

- 90% of set pressure
Metal seat contains media
No leakage - bubble tight
- Seat tightness maintained at pressures above 90% after initial closure

Set Pressure (psig)	Percent of Set Pressure
5 to 30	90%
31 to 50	92%
51 to 100	94%
100 to max rating of valve	97%

19096MBP

The 19096MBP Series balanced design safety relief valve provides back pressure compensation characteristics that meet the needs of various plant operating systems in today's industrial markets. This design is in compliance with ASME B & PVC, Section VIII requirements. The 19096MBP's versatile design is for use in both compressible and incompressible services.

Features and Benefits

Blowdown performance is typically less than 7% on compressible fluids and typically 15% for fixed blowdown on incompressible applications. This performance minimizes the loss of process fluids during an overpressure excursion and assists in the reduction of operating costs.

An O-Ring seat design provides for leak-tight seals during normal system operation and after cycling during a pressure-relieving mode. Media loss due to seat leakage is eliminated, resulting in savings from the cost of lost product.

A simple design that is easily maintained contributes to reduced maintenance costs and parts inventory.

Versatile Service Conditions

- Compressible and incompressible media
- Upper spring chamber not exposed to process media
- Corrosion resistant stainless steel trim
- Special alloy construction available

Increased Operating Efficiency

- Soft seat design provides maximum seat tightness
- Reduces product loss due to leakage
- Consistent fixed blowdown



19096MBP Performance Criteria

Typical Blowdown as a percent of set pressure	1/2" through 1" in either threaded, socket weld or 1" flanged design
Allowable total Backpressure (The sum of the variable and constant backpressure, superimposed and built-up).	1" threaded, socket weld or flanged design .096 Sq. in. (61.9 Sq. mm) 50 psig to 2000 psig -60°F to 600°F (-51°C to 315°C)
Seat Tightness Bubble Tight	ASME B & PVC, Section VIII 400 psig - Variable and/or Constant

Scope of Design

Inlet Sizes	1/2" through 1" in either threaded, socket weld or 1" flanged design
Outlet Sizes	1" threaded, socket weld or flanged design
Orifice Size	.096 Sq. in. (61.9 Sq. mm)
Set Pressure Range	50 psig to 2000 psig
Temperature Range	-60°F to 600°F (-51°C to 315°C)
Certification	ASME B & PVC, Section VIII
Backpressure	400 psig - Variable and/or Constant

Orifice	Pressure Range (psig)	Standard Valve Type (in.)	Standard Connections (in.)
.096 Sq. in. (61.9 Sq. mm)	50 to 2000	1/2-19096M-BP	1/2 - MNPT x 1 - FNPT
		3/4-19096M-BP	3/4 - MNPT x 1 - FNPT 3/4 - FNPT x 1 - FNPT
		1-19096M-BP	1 - MNPT x 1 - FNPT

Soft Seat Material Temperature Limits (°F)

Material	Temperature Limits (°F)
Nitrile	-45 to +350°
Ethylene/Propylene	-70 to +500°
Fluoro-Carbon	-15 to +400°
Fluoro-Silicone	-100 to +350°
Neoprene	-45 to +300°
Silicone	-65 to +437°
Teflon	-300 to +505°

NOTE: Contact factory for other O-Ring materials and the respective temperature limitations.

Materials

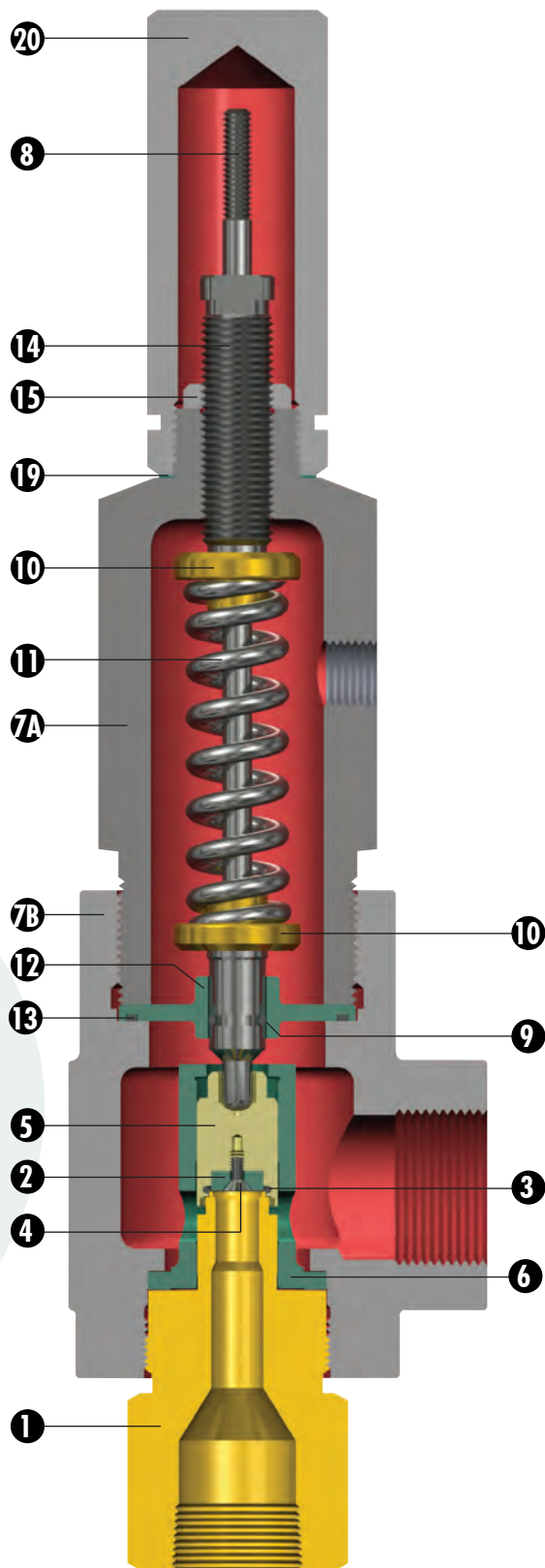

19096MBP

Part	Material	
1	Base	316 SS
2	O-Ring Retainer	316 SS
3	Seat O-Ring	(See O-Ring Seal Selection Table*)
4	Retainer Lockscrew	316 SS
5	Disc Holder	Inconel
6	Guide	316 SS
7A	Bonnet Top	SA105 Carbon Steel (Phosphated)
7B	Bonnet Bottom	SA105 Carbon Steel (Phosphated)
8	Spindle	Inconel
9	Spindle O-Ring	(See O-Ring Selection*)
10	Spring Washer	Carbon Steel (Phosphated)
11	Spring	
	19096c-BP	17-7 PH SS
	19096t-BP	Inconel X750
12	Backup Plate	316 SS
13	Backup Plate O-Ring	(See O-Ring Selection*)
14	Adjusting Screw	316 SS
15	Adj. Screw Locknut	316 SS
16	Gag Bolt	Carbon Steel
17	Sealing Plug	Carbon Steel
18	Sealing Plug Gasket	Soft Iron
19	Cap Gasket	Soft Iron
20	Screwed Cap	Carbon Steel (Phosphated)
21	Release Nut	Carbon Steel
22	Release Locknut	Carbon Steel
23	Plain Lever Cap	Malleable Iron
24	Lifting Lever	Malleable Iron
25	Cap Screw	Carbon Steel
26	Lever Pin	Carbon Steel

* Backup Plate and Spindle O-Ring material will be the same as the O-Ring material selected for Seat O-Ring.

Sour Gas (SG) or NACE applications

The 19096MBP valve materials are standard except for the spring, which will be Inconel X750.

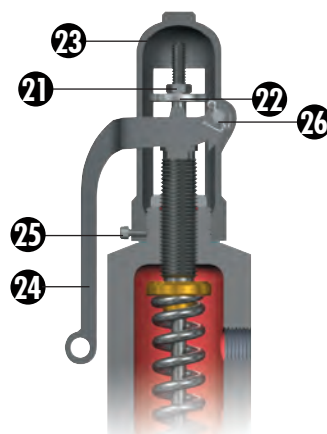

Plain Lever

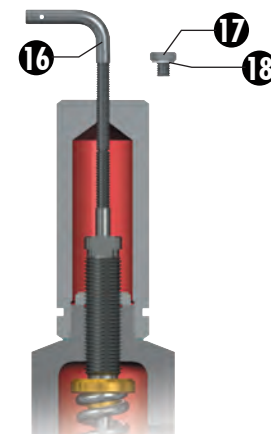

Cap with Gag

Standard and 316 Stainless Steel Variations

Part	Standard Valve	316 Stainless Steel Variations			
		S2	S3	S4	C1
Base 19000L	SA479 Type 316SS	SA479 Type 316SS	SA479 Type 316SS	SA479 Type 316SS	SA479 Type 316SS
Base 19000M	SA479 Type 316SS	SA479 Type 316SS	SA479 Type 316SS	SA479 Type 316SS	SA479 Type 316SS
Base 19000H	SA479 Type 316SS	SA479 Type 316SS	SA479 Type 316SS	SA479 Type 316SS	SA479 Type 316SS
Inlet Nipple	Stellite Seats	Stellite Seats	Stellite Seats	Stellite Seats	Stellite Seats
Outlet Nipple	316SS	316SS	316SS	316SS	316SS
Inlet Extension	Carbon Steel	Carbon Steel	Carbon Steel	Carbon Steel	Carbon Steel
Inlet Flange	316SS	316SS	316SS	316SS	316SS
Outlet Extension	Carbon Steel	Carbon Steel	Carbon Steel	Carbon Steel	Carbon Steel
Outlet Flange	316SS	316SS	316SS	316SS	316SS
Disc 19000 L & M	Carbon Steel	Carbon Steel	Carbon Steel	Carbon Steel	Carbon Steel
Disc 19000 L & M (Steam)*	316SS	316SS	316SS	316SS	316SS
Disc 19000H	616SS	616SS	616SS	616SS	616SS
O-Ring Retainer 19000L	Inconel X750	Inconel X750	Inconel X750	Inconel X750	Inconel X750
O-Ring Retainer 19000M	316SS	316SS	316SS	316SS	316SS
O-Ring Retainer 19000H	316SS	316SS	316SS	316SS	316SS
Retainer Lock Screw	Inconel X750	Inconel X750	Inconel X750	Inconel X750	Inconel X750
O-Ring Disc Holder 19000L	316SS	316SS	316SS	316SS	316SS
O-Ring Disc Holder 19000M	316SS	316SS	316SS	316SS	316SS
O-Ring Disc Holder 19000H	Inconel	Inconel	Inconel	Inconel	Inconel
MS Disc Holder 19000L	Inconel	Inconel	Inconel	Inconel	Inconel
MS Disc Holder 19000M	316SS	316SS	316SS	316SS	316SS
MS Disc Holder 19000H	316SS	316SS	316SS	316SS	316SS
O-Ring Seat Seal	316SS	316SS	316SS	316SS	316SS
Guide	Select	Select	Select	Select	Select
Bonnet	316SS	316SS	316SS	316SS	316SS
O-Ring Spindle 19000L	SA216, WCC CS	SA216, WCC CS	SA351, CF8M	SA351, CF8M	SA352, LCC
O-Ring Spindle 19000M	316SS	316SS	316SS	316SS	316SS
O-Ring Spindle 19000H	Inconel	Inconel	Inconel	Inconel	Inconel
MS Spindle 19000L	Inconel	Inconel	Inconel	Inconel	Inconel
MS Spindle 19000M	316SS	316SS	316SS	316SS	316SS
MS Spindle 19000H	316SS	316SS	316SS	316SS	316SS
Spring Washer	Inconel	Inconel	Inconel	Inconel	Inconel
Spring 19000Lc	Carbon Steel	Carbon Steel	Carbon Steel	316SS	316SS
Spring 19000Lt	17-7PH	17-7PH	17-7PH	17-7PH	17-7PH
Spring 19000Mc	Inconel X750	Inconel X750	Inconel X750	Inconel X750	Inconel X750
Spring 19000Mt	17-7PH	17-7PH	17-7PH	17-7PH	17-7PH
Spring 19000Hc	Inconel X750	Inconel X750	Inconel X750	Inconel X750	Inconel X750
Spring 19000Ht	17-7PH	17-7PH	17-7PH	17-7PH	17-7PH
Spring 19000Ht	Inconel X750	Inconel X750	Inconel X750	Inconel X750	Inconel X750
Adjusting Screw	316SS	316SS	316SS	316SS	316SS
Adj. Screw Lock Nut	316SS	316SS	316SS	316SS	316SS
Cap Gasket	Soft Iron	Soft Iron	Monel	Monel	Soft Iron
Screwed Cap	Carbon Steel	Carbon Steel	316SS	316SS	316SS
Packed Cap	Carbon Steel	Carbon Steel	316SS	316SS	316SS
Cam Shaft	Carbon Steel	Carbon Steel	316SS	316SS	316SS
Bushing	410SS	410SS	316SS	316SS	410SS
Bushing Gasket	416SS	416SS	316SS	316SS	416SS
Packed Lifting Lever	Soft Iron	Soft Iron	Monel	Monel	Soft Iron
Drive Pin	Malleable Iron	Malleable Iron	316SS	316SS	Malleable Iron
O-Ring (Packed Cap)	Steel (Ni-Plated)	Steel (Ni-Plated)	303SS	303SS	Steel (Ni-Plated)
Release Nut	Viton 70	Viton 70	Viton 70	Viton 70	EPR-70
Release Lock Nut	Carbon Steel	Carbon Steel	316SS	316SS	Carbon Steel
Plain Lever Cap	Carbon Steel	Carbon Steel	316SS	316SS	Carbon Steel
Plain Lifting Lever	Malleable Iron	Malleable Iron	316SS	316SS	Malleable Iron
Cap Screw	Malleable Iron	Malleable Iron	316SS	316SS	Malleable Iron
Lever Pin	Carbon Steel	Carbon Steel	316SS	316SS	Carbon Steel
Gag Bolt	Carbon Steel	Carbon Steel	316SS	316SS	Carbon Steel
Sealing Plug	Carbon Steel	Carbon Steel	316SS	316SS	Carbon Steel
Sealing Plug Gasket	Carbon Steel	Carbon Steel	316SS	316SS	Carbon Steel
Bottom Bonnet 19096MBP	Soft Iron	Soft Iron	Monel	Monel	Soft Iron
Top Bonnet 19096MBP	SA105, CS	SA105, CS	SA316, SS	SA316, SS	SA316, SS
Backup Plate 19096MBP	SA105, CS	SA105, CS	SA316, SS	SA316, SS	SA316, SS
Backup Plate O-Ring 19096MBP	316SS	316SS	316SS	316 SS	316SS
Spindle O-Ring 19096MBP	Same as O-Ring Seat	Same as O-Ring Seat	Same as O-Ring Seat	Same as O-Ring Seat	Same as O-Ring Seat

* Supplied for steam service above 251°F (121.7°C)

Monel Variations

Part	Monel				
	M1	MB	M2	M3	M4
Base 19000L	Monel	Monel	Monel	Monel	Monel
Base 19000M	Monel	Monel	Monel	Monel	Monel
Base 19000H	Inconel 625 Stellite Seats	Inconel 625 Stellite Seats	Inconel 625 Stellite Seats	Inconel 625 Stellite Seats	Inconel 625 Stellite Seats
Inlet Nipple	Monel	Monel	Monel	Monel	Monel
Outlet Nipple	316SS	316SS	316SS	316SS	316SS
Inlet Extension	Monel	Monel	Monel	Monel	Monel
Inlet Flange	Carbon Steel	Carbon Steel	Carbon Steel	Monel	Monel
Outlet Extension	316SS	316SS	316SS	316SS	316SS
Outlet Flange	Carbon Steel	Carbon Steel	Carbon Steel	Monel	Monel
Disc 19000 L & M	Monel	Monel	Monel	Monel	Monel
Disc 19000 L & M (Steam)*	Inconel X750	Inconel X750	Inconel X750	Inconel X750	Inconel X750
Disc 19000H	Inconel X750	Inconel X750	Inconel X750	Inconel X750	Inconel X750
O-Ring Retainer 19000L	Monel	Monel	Monel	Monel	Monel
O-Ring Retainer 19000M	Monel	Monel	Monel	Monel	Monel
O-Ring Retainer 19000H	Inconel X750	Inconel X750	Inconel X750	Inconel X750	Inconel X750
Retainer Lock Screw	Monel	Monel	Monel	Monel	Monel
O-Ring Disc Holder 19000L	Monel	Monel	Monel	Monel	Monel
O-Ring Disc Holder 19000M	Inconel	Inconel	Inconel	Inconel	Inconel
O-Ring Disc Holder 19000H	Inconel	Inconel	Inconel	Inconel	Inconel
MS Disc Holder 19000L	316SS	Monel	Monel	Monel	Monel
MS Disc Holder 19000M	316SS	Monel	Monel	Monel	Monel
MS Disc Holder 19000H	316SS	Monel	Monel	Monel	Monel
O-Ring Seat Seal	Select	Select	Select	Select	Select
Guide	316SS	Monel	Monel	Monel	Monel
Bonnet	SA216, WCC CS	SA216, WCC CS	SA216, WCC CS	A494 M35-1 Nickel Copper Alloy	A494 M35-1 Nickel Copper Alloy
O-Ring Spindle 19000L	316SS	316SS	Monel	Monel	Monel
O-Ring Spindle 19000M	Inconel	Inconel	Inconel	Inconel	Inconel
O-Ring Spindle 19000H	Inconel	Inconel	Inconel	Inconel	Inconel
MS Spindle 19000L	316SS	316SS	Monel	Monel	Monel
MS Spindle 19000M	316SS	316SS	Monel	Monel	Monel
MS Spindle 19000H	Inconel	Inconel	Inconel	Inconel	Inconel
Spring Washer	Carbon Steel	Carbon Steel	Carbon Steel	Carbon Steel	Monel
Spring 19000Lc	17-7 PH	17-7 PH	17-7 PH	17-7 PH	Inconel X750
Spring 19000Lt	Inconel X750	Inconel X750	Inconel X750	Inconel X750	Inconel X750
Spring 19000Mc	17-7 PH	17-7 PH	17-7 PH	17-7 PH	Inconel X750
Spring 19000Mt	Inconel X750	Inconel X750	Inconel X750	Inconel X750	Inconel X750
Spring 19000Hc	17-7 PH	17-7 PH	17-7 PH	17-7 PH	Inconel X750
Spring 19000Ht	Inconel X750	Inconel X750	Inconel X750	Inconel X750	Inconel X750
Adjusting Screw	316SS	316SS	316SS	Monel	Monel
Adj. Screw Lock Nut	316SS	316SS	316SS	316SS	316SS
Cap Gasket	Soft Iron	Soft Iron	Soft Iron	Monel	Monel
Screwed Cap	Carbon Steel	Carbon Steel	Carbon Steel	Monel	Monel
Packed Cap	Carbon Steel	Carbon Steel	Carbon Steel	-	-
Cam Shaft	410SS	410SS	410SS	-	-
Bushing	416SS	416SS	416SS	-	-
Bushing Gasket	Soft Iron	Soft Iron	Soft Iron	-	-
Packed Lifting Lever	Malleable Iron	Malleable Iron	Malleable Iron	-	-
Drive Pin	Steel (Ni-Plated)	Steel (Ni-Plated)	Steel (Ni-Plated)	-	-
O-Ring (Packed Cap)	Viton 70	Viton 70	Viton 70	-	-
Release Nut	Carbon Steel	Carbon Steel	Carbon Steel	-	-
Release Lock Nut	Carbon Steel	Carbon Steel	Carbon Steel	-	-
Plain Lever Cap	Malleable Iron	Malleable Iron	Malleable Iron	-	-
Plain Lifting Lever	Malleable Iron	Malleable Iron	Malleable Iron	-	-
Cap Screw	Carbon Steel	Carbon Steel	Carbon Steel	-	-
Lever Pin	Carbon Steel	Carbon Steel	Carbon Steel	-	-
Gag Bolt	Carbon Steel	Carbon Steel	Carbon Steel	316SS	316SS
Sealing Plug	Carbon Steel	Carbon Steel	Carbon Steel	Monel	Monel
Sealing Plug Gasket	Soft Iron	Soft Iron	Soft Iron	Monel	Monel
Bottom Bonnet 19096MBP	SA105, CS	SA105, CS	SA105, CS	Monel	Monel
Top Bonnet 19096MBP	SA105, CS	SA105, CS	SA105, CS	Monel	Monel
Backup Plate 19096MBP	Same as O-Ring Seat	Monel	Monel	Monel	Monel
Backup Plate O-Ring 19096MBP	Same as O-Ring Seat	Same as O-Ring Seat	Same as O-Ring Seat	Same as O-Ring Seat	Same as O-Ring Seat
Spindle O-Ring 19096MBP	Same as O-Ring Seat	Same as O-Ring Seat	Same as O-Ring Seat	Same as O-Ring Seat	Same as O-Ring Seat

* Supplied for steam service above 251°F (121.7°C)

Hastelloy Variations

Part	Hastelloy			
	H1	H2	H3	H4
Base 19000L	Hastelloy	Hastelloy	Hastelloy	Hastelloy
Base 19000M	Hastelloy	Hastelloy	Hastelloy	Hastelloy
Base 19000H	Inconel 625	Inconel 625	Inconel 625	Inconel 625
	Stellite Seats	Stellite Seats	Stellite Seats	Stellite Seats
Inlet Nipple	Hastelloy	Hastelloy	Hastelloy	Hastelloy
Outlet Nipple	316SS	316SS	Hastelloy	Hastelloy
Inlet Extension	Hastelloy	Hastelloy	Hastelloy	Hastelloy
Inlet Flange	Carbon Steel	Carbon Steel	Hastelloy	Hastelloy
Outlet Extension	316SS	316SS	Hastelloy	Hastelloy
Outlet Flange	Carbon Steel	Carbon Steel	Hastelloy	Hastelloy
Disc 19000 L & M	Hastelloy	Hastelloy	Hastelloy	Hastelloy
Disc 19000 L & M (Steam)*	Inconel X750	Inconel X750	Inconel X750	Inconel X750
Disc 19000H	Inconel X750	Inconel X750	Inconel X750	Inconel X750
O-Ring Retainer 19000L	Hastelloy	Hastelloy	Hastelloy	Hastelloy
O-Ring Retainer 19000M	Hastelloy	Hastelloy	Hastelloy	Hastelloy
O-Ring Retainer 19000H	Inconel X750	Inconel X750	Inconel X750	Inconel X750
Retainer Lock Screw	Hastelloy	Hastelloy	Hastelloy	Hastelloy
O-Ring Disc Holder 19000L	Hastelloy	Hastelloy	Hastelloy	Hastelloy
O-Ring Disc Holder 19000M	Inconel	Inconel	Inconel	Inconel
O-Ring Disc Holder 19000H	Inconel	Inconel	Inconel	Inconel
MS Disc Holder 19000L	316SS	Hastelloy	Hastelloy	Hastelloy
MS Disc Holder 19000M	316SS	Hastelloy	Hastelloy	Hastelloy
MS Disc Holder 19000H	316SS	Hastelloy	Hastelloy	Hastelloy
O-Ring Seat Seal	Select	Select	Select	Select
Guide	316SS	Hastelloy	Hastelloy	Hastelloy
Bonnet	SA216, WCC CS	SA216, WCC CS	SA494 CW12 MW Nickel Alloy	SA494 CW12 MW Nickel Alloy
O-Ring Spindle 19000L	316SS	Hastelloy	Hastelloy	Hastelloy
O-Ring Spindle 19000M	Inconel	Inconel	Inconel	Inconel
O-Ring Spindle 19000H	Inconel	Inconel	Inconel	Inconel
MS Spindle 19000L	316SS	Hastelloy	Hastelloy	Hastelloy
MS Spindle 19000M	316SS	Hastelloy	Hastelloy	Hastelloy
MS Spindle 19000H	Inconel	Inconel	Inconel	Inconel
Spring Washer	Carbon Steel	Carbon Steel	Carbon Steel	Hastelloy
Spring 19000Lc	17-7 PH	17-7 PH	17-7 PH	Hastelloy
Spring 19000Lr	Inconel X750	Inconel X750	Inconel X750	Inconel X750
Spring 19000Mc	17-7 PH	17-7 PH	17-7 PH	Inconel X750
Spring 19000Mt	Inconel X750	Inconel X-750	Inconel X-750	Inconel X750
Spring 19000Hc	17-7 PH	17-7 PH	17-7 PH	Inconel X750
Spring 19000Ht	Inconel X750	Inconel X750	Inconel X750	Inconel X750
Adjusting Screw	316SS	316SS	Hastelloy	Hastelloy
Adj. Screw Lock Nut	316SS	316SS	Hastelloy	Hastelloy
Cap Gasket	Soft Iron	Soft Iron	Monel	Monel
Screwed Cap	Carbon Steel	Carbon Steel	Hastelloy	Hastelloy
Packed Cap	Carbon Steel	Carbon Steel	-	-
Cam Shaft	410SS	410SS	-	-
Bushing	416SS	416SS	-	-
Bushing Gasket	Soft Iron	Soft Iron	-	-
Packed Lifting Lever	Malleable Iron	Malleable Iron	-	-
Drive Pin	Steel (Ni-Plated)	Steel (Ni-Plated)	-	-
O-Ring (Packed Cap)	Viton 70	Viton 70	-	-
Release Nut	Carbon Steel	Carbon Steel	-	-
Release Lock Nut	Carbon Steel	Carbon Steel	-	-
Plain Lever Cap	Malleable Iron	Malleable Iron	-	-
Plain Lifting Lever	Malleable Iron	Malleable Iron	-	-
Cap Screw	Carbon Steel	Carbon Steel	-	-
Lever Pin	Carbon Steel	Carbon Steel	-	-
Gag Bolt	Carbon Steel	Carbon Steel	316SS	316SS
Sealing Plug	Carbon Steel	Carbon Steel	Hastelloy	Hastelloy
Sealing Plug Gasket	Soft Iron	Soft Iron	Monel	Monel
Bottom Bonnet 19096MBP	SA105, CS	SA105, CS	Hastelloy	Hastelloy
Top Bonnet 19096MBP	SA105, CS	SA105, CS	Hastelloy	Hastelloy
Backup Plate 19096MBP	Same as O-Ring Seat	Hastelloy	Hastelloy	Hastelloy
Backup Plate O-Ring 19096MBP	Same as O-Ring Seat	Same as O-Ring Seat	Same as O-Ring Seat	Same as O-Ring Seat
Spindle O-Ring 19096MBP		Same as O-Ring Seat	Same as O-Ring Seat	Same as O-Ring Seat

* Supplied for steam service above 251°F (121.7°C)

Alloy 20 Variations

Part	Alloy 20			
	A1	A2	A3	A4
Base 19000L	Alloy 20	Alloy 20	Alloy 20	Alloy 20
Base 19000M	Alloy 20	Alloy 20	Alloy 20	Alloy 20
Base 19000H	Inconel 625	Inconel 625	Inconel 625	Inconel 625
	Stellite Seats	Stellite Seats	Stellite Seats	Stellite Seats
Inlet Nipple	Alloy 20	Alloy 20	Alloy 20	Alloy 20
Outlet Nipple	316SS	316SS	Alloy 20	Alloy 20
Inlet Extension	Alloy 20	Alloy 20	Alloy 20	Alloy 20
Inlet Flange	Carbon Steel	Carbon Steel	Alloy 20	Alloy 20
Outlet Extension	316SS	316SS	Alloy 20	Alloy 20
Outlet Flange	Carbon Steel	Carbon Steel	Alloy 20	Alloy 20
Disc 19000 L & M	Alloy 20	Alloy 20	Alloy 20	Alloy 20
Disc 19000 L & M (Steam)*	Inconel X750	Inconel X750	Inconel X750	Inconel X750
Disc 19000H	Inconel X750	Inconel X750	Inconel X750	Inconel X750
O-Ring Retainer 19000L	Alloy 20	Alloy 20	Alloy 20	Alloy 20
O-Ring Retainer 19000M	Alloy 20	Alloy 20	Alloy 20	Alloy 20
O-Ring Retainer 19000H	Inconel X750	Inconel X750	Inconel X750	Inconel X750
Retainer Lock Screw	Alloy 20	Alloy 20	Alloy 20	Alloy 20
O-Ring Disc Holder 19000L	Alloy 20	Alloy 20	Alloy 20	Alloy 20
O-Ring Disc Holder 19000M	Inconel	Inconel	Inconel	Inconel
O-Ring Disc Holder 19000H	Inconel	Inconel	Inconel	Inconel
MS Disc Holder 19000L	316SS	Alloy 20	Alloy 20	Alloy 20
MS Disc Holder 19000M	316SS	Alloy 20	Alloy 20	Alloy 20
MS Disc Holder 19000H	316SS	Alloy 20	Alloy 20	Alloy 20
O-Ring Seat Seal	Select	Select	Select	Select
Guide	316SS	Alloy 20	Alloy 20	Alloy 20
Bonnet	SA216, WCC CS	SA216, WCC CS	SA351 CN7M	SA351 CN7M
O-Ring Spindle 19000L	316SS	Alloy 20	Alloy 20	Alloy 20
O-Ring Spindle 19000M	Inconel	Inconel	Inconel	Inconel
O-Ring Spindle 19000H	Inconel	Inconel	Inconel	Inconel
MS Spindle 19000L	316SS	Alloy 20	Alloy 20	Alloy 20
MS Spindle 19000M	316SS	Alloy 20	Alloy 20	Alloy 20
MS Spindle 19000H	Inconel	Inconel	Inconel	Inconel
Spring Washer	Carbon Steel	Carbon Steel	Carbon Steel	Alloy 20
Spring 19000Lc	17-7 PH	17-7 PH	17-7 PH	Alloy 20
Spring 19000Lt	Inconel X750	Inconel X750	Inconel X750	Inconel X750
Spring 19000Mc	17-7 PH	17-7 PH	17-7 PH	Inconel X750
Spring 19000Mt	Inconel X750	Inconel X750	Inconel X750	Inconel X750
Spring 19000Hc	17-7 PH	17-7 PH	17-7 PH	Inconel X750
Spring 19000Ht	Inconel X750	Inconel X750	Inconel X750	Inconel X750
Adjusting Screw	316SS	316SS	Alloy 20	Alloy 20
Adj. Screw Lock Nut	316SS	316SS	Alloy 20	Alloy 20
Cap Gasket	Soft Iron	Soft Iron	Monel	Monel
Screwed Cap	Carbon Steel	Carbon Steel	Alloy 20	Alloy 20
Packed Cap	Carbon Steel	Carbon Steel	-	-
Cam Shaft	410SS	410SS	-	-
Bushing	416SS	416SS	-	-
Bushing Gasket	Soft Iron	Soft Iron	-	-
Packed Lifting Lever	Malleable Iron	Malleable Iron	-	-
Drive Pin	Steel (Ni-Plated)	Steel (Ni-Plated)	-	-
O-Ring (Packed Cap)	Viton 70	Viton 70	-	-
Release Nut	Carbon Steel	Carbon Steel	-	-
Release Lock Nut	Carbon Steel	Carbon Steel	-	-
Plain Lever Cap	Malleable Iron	Malleable Iron	-	-
Plain Lifting Lever	Malleable Iron	Malleable Iron	-	-
Cap Screw	Carbon Steel	Carbon Steel	-	-
Lever Pin	Carbon Steel	Carbon Steel	-	-
Gag Bolt	Carbon Steel	Carbon Steel	316SS	316SS
Sealing Plug	Carbon Steel	Carbon Steel	Alloy 20	Alloy 20
Sealing Plug Gasket	Soft Iron	Soft Iron	Monel	Monel
Bottom Bonnet 19096MBP	SA105	SA105	Alloy 20	Alloy 20
Top Bonnet 19096MBP	SA105	SA105	Alloy 20	Alloy 20
Backup Plate 19096MBP	Alloy 20	Alloy 20	Alloy 20	Alloy 20
Backup Plate O-Ring 19096MBP	Same as O-Ring Seat	Same as O-Ring Seat	Same as O-Ring Seat	Same as O-Ring Seat
Spindle O-Ring 19096MBP	Same as O-Ring Seat	Same as O-Ring Seat	Same as O-Ring Seat	Same as O-Ring Seat

* Supplied for steam service above 251°F (121.7°C)

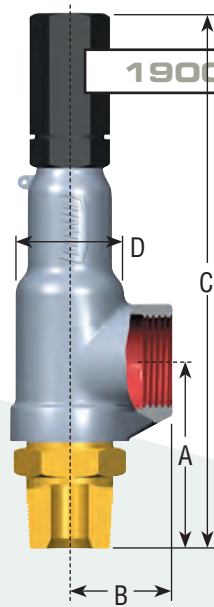

19000 Threaded Connections

CAUTION
Do not seal weld inlet and outlet connections.

19096MBP Threaded Connections

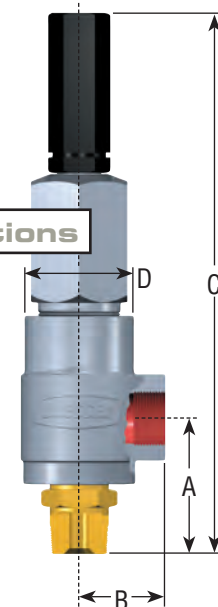

The key to selecting the appropriate dimensions is to use the numbers in the column named "Type". The "Size" column defines the valve by inlet size and connection type, then by outlet size and connection type.

Example: 1/2 - MNPT x 1 - FNPT

Inlet size is 1/2" with a male NPT pipe thread and the outlet is 1" size with a female NPT pipe thread. "SW" indicates socket weld. "Flanged Connections" show size of flange and pressure rating.

- NOTES: 1 "USCS" Units refers to "U.S. Customary System" Units, the adopted U.S. Standard formerly recognized as "English" Units.
2 Valves are provided with a male pipe threaded (MNPT) or a female pipe threaded (FNPT) inlet connection as specified in the table below.

Threaded Connections (Inches & Pounds)

Size (in.)	Type	A	B	C		D		Approx. Weight	
				19000	MBP	19000	MBP	19000	MBP
3/4 - FNPT x 1 - FNPT	19096L	3-1/8	1-7/8	10-1/4	N/A	2	N/A	4-1/2	N/A
1/2 - MNPT x 1 - FNPT	19096L	3-1/4	1-7/8	10-3/8	N/A	2	N/A	4-3/4	N/A
3/4 - MNPT x 1 - FNPT	19096L	3-1/4	1-7/8	10-3/8	N/A	2	N/A	4-3/4	N/A
1 - MNPT x 1 - FNPT	19096L	3-1/4	1-7/8	10-3/8	N/A	2	N/A	4-3/4	N/A
3/4 - FNPT x 1 - FNPT	19096M	3-1/8	2	12-1/16	12-3/4	2-9/16	3-3/4	6-1/2	11-1/2
1/2 - MNPT x 1 - FNPT	19096M	3-1/4	2	12-3/16	12-7/8	2-9/16	3-3/4	6-1/2	11-1/2
3/4 - MNPT x 1 - FNPT	19096M	3-1/4	2	12-3/16	12-7/8	2-9/16	3-3/4	6-1/2	11-1/2
1 - MNPT x 1 - FNPT	19096M	3-1/4	2	12-3/16	12-7/8	2-9/16	3-3/4	6-1/2	11-1/2
3/4 - FNPT x 1 - FNPT	19096H	3-1/8	2-3/8	12-1/2	N/A	3-1/8	N/A	11-1/2	N/A
3/4 - FNPT x 1 - FNPT	19110L	3-1/8	1-7/8	10-1/4	N/A	2	N/A	4-1/2	N/A
1/2 - MNPT x 1 - FNPT	19110L	3-1/4	1-7/8	10-3/8	N/A	2	N/A	4-3/4	N/A
3/4 - MNPT x 1 - FNPT	19110L	3-1/4	1-7/8	10-3/8	N/A	2	N/A	4-3/4	N/A
1 - MNPT x 1 - FNPT	19110L	3-1/4	1-7/8	10-3/8	N/A	2	N/A	4-3/4	N/A
3/4 - FNPT x 1 - FNPT	19110M	3-1/8	2	12-1/16	N/A	2-9/16	N/A	6-1/2	N/A
1/2 - MNPT x 1 - FNPT	19110M	3-1/4	2	12-3/16	N/A	2-9/16	N/A	6-1/2	N/A
3/4 - MNPT x 1 - FNPT	19110M	3-1/4	2	12-3/16	N/A	2-9/16	N/A	6-1/2	N/A
1 - MNPT x 1 - FNPT	19110M	3-1/4	2	12-3/16	N/A	2-9/16	N/A	6-1/2	N/A
3/4 - FNPT x 1 - FNPT	19110H	3-1/8	2-3/8	12-1/2	N/A	3-1/8	N/A	11-1/2	N/A
3/4 - FNPT x 1 - FNPT	19126L	3-1/8	1-7/8	10-1/4	N/A	2	N/A	5	N/A
3/4 - MNPT x 1 - FNPT	19126L	3-1/4	1-7/8	10-3/8	N/A	2	N/A	5-1/4	N/A
1 - MNPT x 1 - FNPT	19126L	3-1/4	1-7/8	10-3/8	N/A	2	N/A	5-1/4	N/A
3/4 - FNPT x 1 - FNPT	19126M	3-1/8	2	12-1/16	N/A	2-9/16	N/A	6-1/2	N/A
3/4 - MNPT x 1 - FNPT	19126M	3-1/4	2	12-3/16	N/A	2-9/16	N/A	6-1/2	N/A
1 - MNPT x 1 - FNPT	19126M	3-1/4	2	12-3/16	N/A	2-9/16	N/A	6-1/2	N/A
3/4 - FNPT x 1 - FNPT	19126H	3-1/8	3-1/8	15-15/16	N/A	4-5/8	N/A	30	N/A
1 - FNPT x 1-1/2 - FNPT	19226L	3-3/8	2-1/4	11-3/8	N/A	2-3/8	N/A	6-1/2	N/A
1 - MNPT x 1-1/2 - FNPT	19226L	3-5/8	2-1/4	11-5/8	N/A	2-3/8	N/A	6-3/4	N/A
1 - FNPT x 1-1/2 - FNPT	19226M	3-3/8	2-3/8	12-3/4	N/A	3-1/8	N/A	11-1/2	N/A
1 - MNPT x 1-1/2 - FNPT	19226M	3-5/8	2-3/8	13	N/A	3-1/8	N/A	11-1/2	N/A
1 - FNPT x 1-1/2 - FNPT	19226H	3-1/8	3-1/8	15-15/16	N/A	4-5/8	N/A	30	N/A
1-1/2 - FNPT x 2 - FNPT	19357L	4-1/16	3-1/8	15-1/16	N/A	3-5/8	N/A	18	N/A
1-1/2 - FNPT x 2 - FNPT	19357M	4-1/16	3-1/8	16-7/8	N/A	4-5/8	N/A	30	N/A
2 - FNPT x 2-1/2 - FNPT	19567L	4-1/16	3-1/8	15-1/16	N/A	3-5/8	N/A	19	N/A
2 - FNPT x 2-1/2 - FNPT	19567M	4-1/16	3-1/8	16-7/8	N/A	4-5/8	N/A	30	N/A

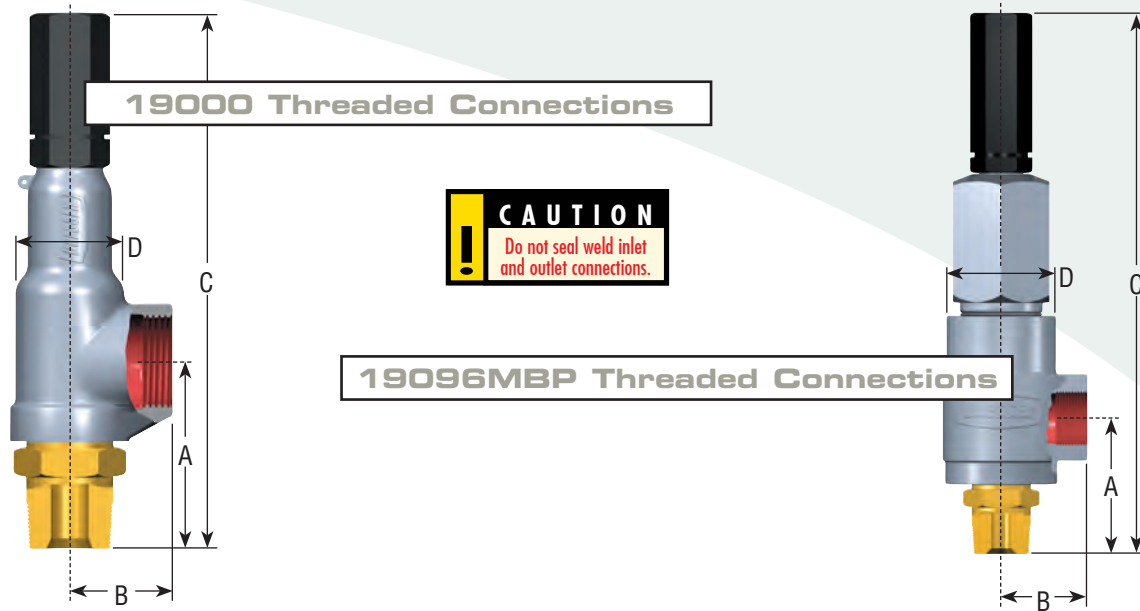

Threaded Connections (Millimeters & Kilograms)

Size (mm)	Type	A	B	C		D		Approx. Weight	
				19000	MBP	19000	MBP	19000	MBP
3/4 - FNPT x 1 - FNPT	19096L	79.4	47.6	260.4	N/A	50.8	N/A	2.0	N/A
1/2 - MNPT x 1 - FNPT	19096L	82.6	47.6	263.5	N/A	50.8	N/A	2.2	N/A
3/4 - MNPT x 1 - FNPT	19096L	82.6	47.6	263.5	N/A	50.8	N/A	2.2	N/A
1 - MNPT x 1 - FNPT	19096L	82.6	47.6	263.5	N/A	50.8	N/A	2.2	N/A
3/4 - FNPT x 1 - FNPT	19096M	79.4	50.8	306.4	323.9	65.1	95.3	2.9	5.2
1/2 - MNPT x 1 - FNPT	19096M	82.6	50.8	309.6	327.0	65.1	95.3	2.9	5.2
3/4 - MNPT x 1 - FNPT	19096M	82.6	50.8	309.6	327.0	65.1	95.3	2.9	5.2
1 - MNPT x 1 - FNPT	19096M	82.6	50.8	309.6	327.0	65.1	95.3	2.9	5.2
3/4 - FNPT x 1 - FNPT	19096H	79.4	60.3	317.5	N/A	79.37	N/A	5.2	N/A
3/4 - FNPT x 1 - FNPT	19110L	79.4	47.6	260.4	N/A	50.8	N/A	2.0	N/A
1/2 - MNPT x 1 - FNPT	19110L	82.6	47.6	263.5	N/A	50.8	N/A	2.2	N/A
3/4 - MNPT x 1 - FNPT	19110L	82.6	47.6	263.5	N/A	50.8	N/A	2.2	N/A
1 - MNPT x 1 - FNPT	19110L	82.6	47.6	263.5	N/A	50.8	N/A	2.2	N/A
3/4 - FNPT x 1 - FNPT	19110M	79.4	50.8	306.4	N/A	65.1	N/A	2.9	N/A
1/2 - MNPT x 1 - FNPT	19110M	82.6	50.8	309.6	N/A	65.1	N/A	2.9	N/A
3/4 - MNPT x 1 - FNPT	19110M	82.6	50.8	309.6	N/A	65.1	N/A	2.9	N/A
1 - MNPT x 1 - FNPT	19110M	82.6	50.8	309.6	N/A	65.1	N/A	2.9	N/A
3/4 - FNPT x 1 - FNPT	19110H	79.4	60.3	317.5	N/A	79.4	N/A	5.2	N/A
3/4 - FNPT x 1 - FNPT	19126L	79.4	47.6	260.4	N/A	50.8	N/A	2.3	N/A
3/4 - MNPT x 1 - FNPT	19126L	82.6	47.6	263.5	N/A	50.8	N/A	2.4	N/A
1 - MNPT x 1 - FNPT	19126L	82.6	47.6	263.5	N/A	50.8	N/A	2.4	N/A
3/4 - FNPT x 1 - FNPT	19126M	79.4	50.8	306.4	N/A	65.1	N/A	2.9	N/A
3/4 - MNPT x 1 - FNPT	19126M	82.6	50.8	309.6	N/A	65.1	N/A	2.9	N/A
1 - MNPT x 1 - FNPT	19126M	82.6	50.8	309.6	N/A	65.1	N/A	2.9	N/A
3/4 - FNPT x 1 - FNPT	19126H	79.4	79.4	404.8	N/A	117.5	N/A	13.6	N/A
1 - FNPT x 1-1/2 - FNPT	19226L	85.7	57.2	288.9	N/A	60.3	N/A	2.9	N/A
1 - MNPT x 1-1/2 - FNPT	19226L	92.1	57.2	295.3	N/A	60.3	N/A	3.1	N/A
1 - FNPT x 1-1/2 - FNPT	19226M	85.7	60.3	323.9	N/A	79.4	N/A	5.2	N/A
1 - MNPT x 1-1/2 - FNPT	19226M	92.1	60.3	330.2	N/A	79.4	N/A	5.2	N/A
1 - FNPT x 1-1/2 - FNPT	19226H	79.4	79.4	404.8	N/A	117.5	N/A	13.6	N/A
1-1/2 - FNPT x 2 - FNPT	19357L	103.2	79.4	382.6	N/A	92.08	N/A	8.2	N/A
1-1/2 - FNPT x 2 - FNPT	19357M	103.2	79.4	428.6	N/A	117.5	N/A	13.6	N/A
2 - FNPT x 2-1/2 - FNPT	19567L	103.2	79.4	382.6	N/A	92.08	N/A	8.6	N/A
2 - FNPT x 2-1/2 - FNPT	19567M	103.2	79.4	428.6	N/A	117.5	N/A	13.6	N/A

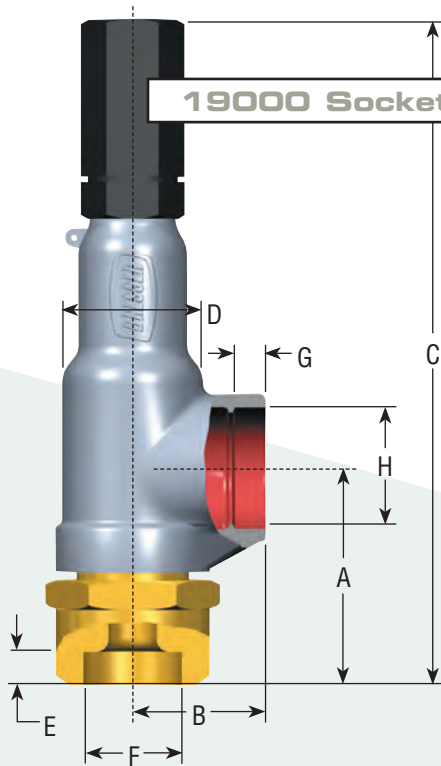

CAUTION
Avoid excessive
weld deposits.

19096MBP Socket Weld

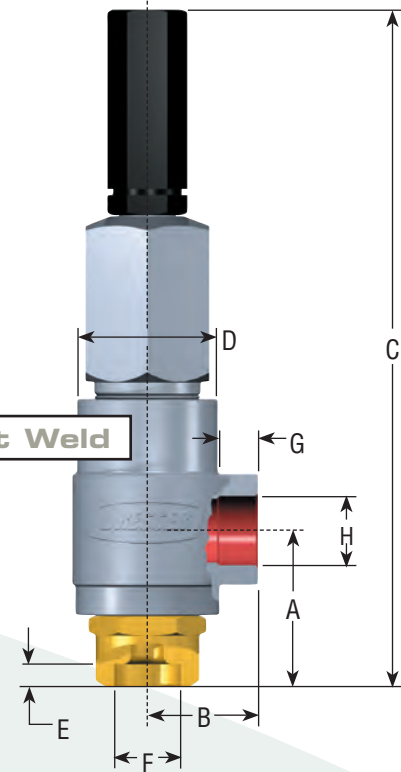

Socket Weld Connections (Inches & Pounds)

Size (in.)	Type	A	B	C		D		E	F Dia.	G	H Dia.	Approx. Weight	
				19000	MBP	19000	MBP					19000	MBP
1/2 - SW x 1 - SW	19096L	3-1/2	1-7/8	10-5/8	N/A	2	N/A	1/2	.855	5/8	1.330	5-1/2	N/A
3/4 - SW x 1 - SW	19096L	3-1/2	1-7/8	10-5/8	N/A	2	N/A	1/2	1.065	5/8	1.330	5-1/2	N/A
1 - SW x 1 - SW	19096L	3-1/2	1-7/8	10-5/8	N/A	2	N/A	1/2	1.330	5/8	1.330	6-1/4	N/A
1/2 - SW x 1 - SW	19096M	3-1/2	2	12-7/16	13-1/8	2-9/16	3-3/4	1/2	.855	5/8	1.330	7	12
3/4 - SW x 1 - SW	19096M	3-1/2	2	12-7/16	13-1/8	2-9/16	3-3/4	1/2	1.065	5/8	1.330	7-1/2	12-1/2
1 - SW x 1 - SW	19096M	3-1/2	2	12-7/16	13-1/8	2-9/16	3-3/4	1/2	1.330	5/8	1.330	8	13
3/4 - SW x 1 - SW	19096H	4	2-3/8	13-3/8	N/A	3-1/8	N/A	1/2	1.065	5/8	1.330	12	N/A
1/2 - SW x 1 - SW	19110L	3-1/2	1-7/8	10-5/8	N/A	2	N/A	1/2	.855	5/8	1.330	5-1/2	N/A
3/4 - SW x 1 - SW	19110L	3-1/2	1-7/8	10-5/8	N/A	2	N/A	1/2	1.065	5/8	1.330	5-1/2	N/A
1 - SW x 1 - SW	19110L	3-1/2	1-7/8	10-5/8	N/A	2	N/A	1/2	1.330	5/8	1.330	6-1/4	N/A
1/2 - SW x 1 - SW	19110M	3-1/2	2	12-7/16	N/A	2-9/16	N/A	1/2	.855	5/8	1.330	7	N/A
3/4 - SW x 1 - SW	19110M	3-1/2	2	12-7/16	N/A	2-9/16	N/A	1/2	1.065	5/8	1.330	7-1/2	N/A
1 - SW x 1 - SW	19110M	3-1/2	2	12-7/16	N/A	2-9/16	N/A	1/2	1.330	5/8	1.330	8	N/A
3/4 - SW x 1 - SW	19110H	4	2-3/8	13-3/8	N/A	3-1/8	N/A	1/2	1.065	5/8	1.330	12	N/A
3/4 - SW x 1 - SW	19126L	3-1/2	1-7/8	10-5/8	N/A	2	N/A	1/2	1.065	5/8	1.330	6	N/A
1 - SW x 1 - SW	19126L	3-1/2	1-7/8	10-5/8	N/A	2	N/A	1/2	1.330	5/8	1.330	6-3/4	N/A
3/4 - SW x 1 - SW	19126M	3-1/2	2	12-7/16	N/A	2-9/16	N/A	1/2	1.065	5/8	1.330	7	N/A
1 - SW x 1 - SW	19126M	3-1/2	2	12-7/16	N/A	2-9/16	N/A	1/2	1.330	5/8	1.330	8	N/A
3/4 - SW x 1 - SW	19126H	4-1/2	3-1/8	17-5/16	N/A	4-5/8	N/A	5/8	1.065	5/8	1.330	32	N/A
1 - SW x 1-1/2 - SW	19226L	3-15/16	2-1/4	11-15/16	N/A	2-3/8	N/A	1/2	1.330	5/8	1.915	8	N/A
1 - SW x 1-1/2 - SW	19226M	3-15/16	2-3/8	13-5/16	N/A	3-1/8	N/A	1/2	1.330	5/8	1.915	12-1/2	N/A
1 - SW x 1-1/2 - SW	19226H	4-1/2	3-1/8	17-5/16	N/A	4-5/8	N/A	5/8	1.330	5/8	1.915	32	N/A
1-1/2 - SW x 2 - SW	19357L	4-3/4	3-1/8	15-3/4	N/A	3-5/8	N/A	5/8	1.915	5/8	2.406	18-1/4	N/A
1-1/2 - SW x 2 - SW	19357M	4-3/4	3-1/8	17-9/16	N/A	4-5/8	N/A	5/8	1.915	5/8	2.406	31	N/A
2 - SW x 2-1/2 - SW	19567L	5-3/8	3-1/8	16-3/8	N/A	3-5/8	N/A	5/8	2.406	5/8	2.906	24	N/A
2 - SW x 2-1/2 - SW	19567M	5-3/8	3-1/8	18-3/16	N/A	4-5/8	N/A	5/8	2.406	5/8	2.906	34	N/A

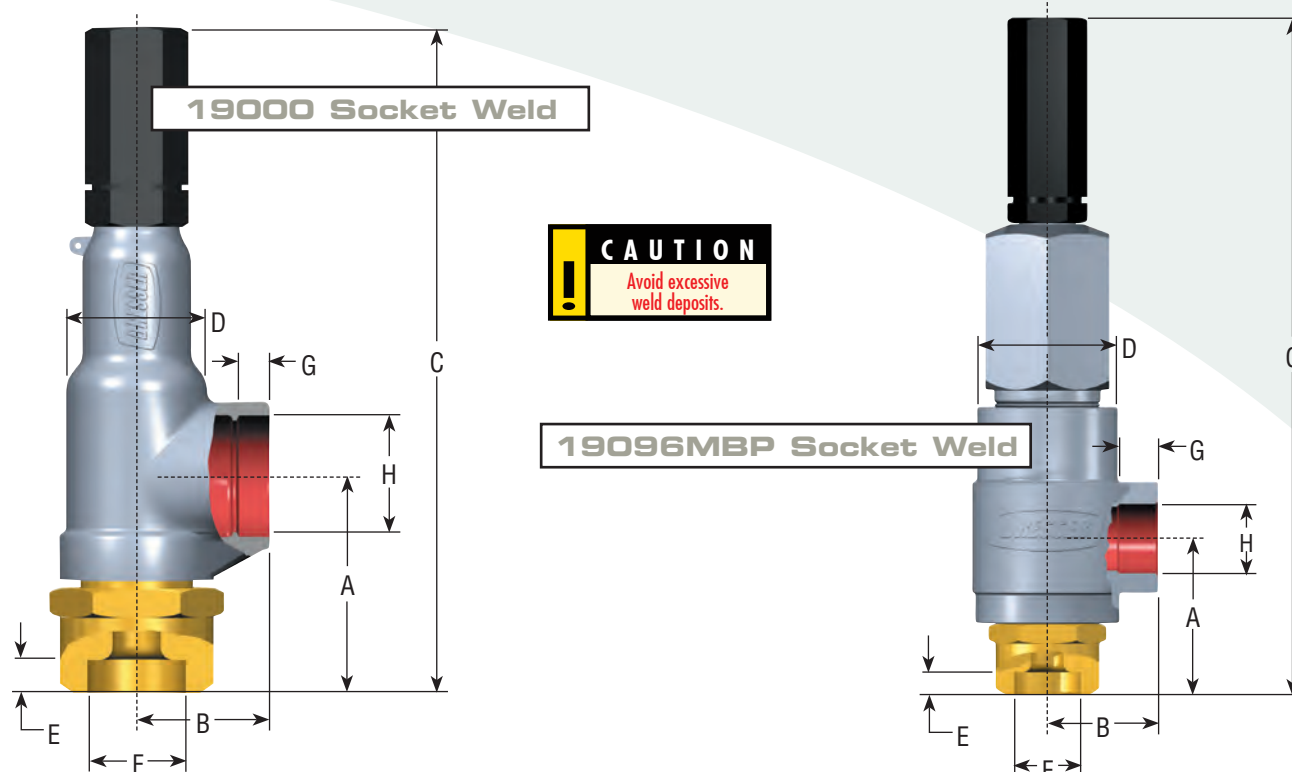

Socket Weld Connections (Millimeters & Kilograms)

Size (mm)	Type	A	B	C		D		E	F Dia.	G	H Dia.	Approx. Weight	
				19000	MBP	19000	MBP					19000	MBP
1/2 - SW x 1 - SW	19096L	88.9	47.6	269.9	N/A	50.8	N/A	12.7	21.7	15.9	33.8	2.5	N/A
3/4 - SW x 1 - SW	19096L	88.9	47.6	269.9	N/A	50.8	N/A	12.7	27.1	15.9	33.8	2.5	N/A
1 - SW x 1 - SW	19096L	88.9	47.6	269.9	N/A	50.8	N/A	12.7	33.8	15.9	33.8	2.8	N/A
1/2 - SW x 1 - SW	19096M	88.9	50.8	315.9	333.4	65.1	95.3	12.7	21.7	15.9	33.8	3.2	5.4
3/4 - SW x 1 - SW	19096M	88.9	50.8	315.9	333.4	65.1	95.3	12.7	27.1	15.9	33.8	3.4	5.6
1 - SW x 1 - SW	19096M	88.9	50.8	315.9	333.4	65.1	95.3	12.7	33.8	15.9	33.8	3.6	5.9
3/4 - SW x 1 - SW	19096H	101.6	60.3	339.7	N/A	79.4	N/A	12.7	27.1	15.9	33.8	5.4	N/A
1/2 - SW x 1 - SW	19110L	88.9	47.6	269.9	N/A	50.8	N/A	12.7	21.7	15.9	33.8	2.5	N/A
3/4 - SW x 1 - SW	19110L	88.9	47.6	269.9	N/A	50.8	N/A	12.7	27.1	15.9	33.8	2.5	N/A
1 - SW x 1 - SW	19110L	88.9	47.6	269.9	N/A	50.8	N/A	12.7	33.8	15.9	33.8	2.8	N/A
1/2 - SW x 1 - SW	19110M	88.9	50.8	315.9	N/A	65.1	N/A	12.7	21.7	15.9	33.8	3.2	N/A
3/4 - SW x 1 - SW	19110M	88.9	50.8	315.9	N/A	65.1	N/A	12.7	27.1	15.9	33.8	3.4	N/A
1 - SW x 1 - SW	19110M	88.9	50.8	315.9	N/A	65.1	N/A	12.7	33.8	15.9	33.8	3.6	N/A
3/4 - SW x 1 - SW	19110H	101.6	60.3	339.7	N/A	79.4	N/A	12.7	27.1	15.9	33.8	5.4	N/A
3/4 - SW x 1 - SW	19126L	88.9	47.6	269.9	N/A	50.8	N/A	12.7	27.1	15.9	33.8	2.7	N/A
1 - SW x 1 - SW	19126L	88.9	47.6	269.9	N/A	50.8	N/A	12.7	33.8	15.9	33.8	3.1	N/A
3/4 - SW x 1 - SW	19126M	88.9	50.8	315.9	N/A	65.1	N/A	12.7	27.1	15.9	33.8	3.2	N/A
1 - SW x 1 - SW	19126M	88.9	50.8	315.9	N/A	65.1	N/A	12.7	33.8	15.9	33.8	3.6	N/A
3/4 - SW x 1 - SW	19126H	114.3	79.4	439.7	N/A	117.5	N/A	15.9	27.1	15.915	33.8	14.5	N/A
1 - SW x 1-1/2 - SW	19226L	100.0	57.2	303.2	N/A	66.3	N/A	12.7	33.8	915.915	48.6	3.6	N/A
1 - SW x 1-1/2 - SW	19226M	100.0	60.3	338.1	N/A	79.4	N/A	12.7	33.8	915.91	48.6	5.7	N/A
1-SW x 1-1/2 - SW	19226H	114.3	79.4	439.7	N/A	117.5	N/A	15.9	33.8	5.915.9	48.6	14.5	N/A
1-1/2 - SW x 2 - SW	19357L	120.7	79.4	400.1	N/A	92.08	N/A	15.9	48.6	15.9	61.1	8.3	N/A
1-1/2 - SW x 2 - SW	19357M	120.7	79.4	446.1	N/A	117.5	N/A	15.9	48.6		61.1	14.1	N/A
2 - SW x 2-1/2 - SW	19567L	136.5	79.4	415.9	N/A	92.08	N/A	15.9	61.1		73.8	10.9	N/A
2 - SW x 2-1/2 - SW	19567M	136.5	79.4	462.0	N/A	117.5	N/A	15.9	61.1		73.8	15.4	N/A

19000 Flanged Connections (Inches & Pounds)

Size (in.)	Type	Inlet (RF or RJ) ANSI Standard Except Thickness	Outlet		A (in.)	B		C (in.)	D (in.)	E (in.)	F (in.)	G		H (in.)	Approx. Weight					
			Female NPT (in.)	(RF or RJ) ANSI Standard Except Thickness		NPT (in.)	Flange (in.)					Class 150#	Class 300#		RF or RJ	RF or RJ	Threaded Outlet (lbs.)	Flanged Outlet (lbs.)		
																			RF or RJ	RF or RJ
																			(in.)	(in.)
1/2	19096L	1/2 - 150	1	1 - 150	6	1-7/8	4-7/8	13-1/8	2	7/8	7/16	1-1/16	—	1/2	6-1/4	9-1/4				
	19110L	1/2 - 300								1					7-1/4	10-1/4				
3/4	19096L	3/4 - 150	1	1 - 150	6-1/4	1-7/8	4-7/8	13-3/8	2	1	1/2	1-1/16	—	1/2	7	10				
	19110L	3/4 - 300								1-1/8					8-1/2	11-1/2				
1	19096L	1 - 150	1	1 - 150	6-1/2	1-7/8	4-7/8	13-5/8	2	1-1/16	1/2	1-1/16	—	1/2	7-3/4	10-3/4				
	19110L	1 - 300								1-3/16					9-1/4	12-1/4				
3/4	19126L	3/4 - 150	1	1 - 150	6-1/4	1-7/8	4-7/8	13-3/8	2	1	1/2	1-1/16	—	1/2	7-1/2	10-1/2				
	19126L	3/4 - 300								1-1/8					9	12				
1	19126L	1 - 150	1	1 - 150	6-1/2	1-7/8	4-7/8	13-5/8	2	1-1/16	1/2	1-1/16	—	1/2	8-1/4	11-1/4				
	19126L	1 - 300								1-3/16					9-3/4	12-3/4				
1	19226L	1 - 150	1-1/2	1-1/2 - 150	6-1/4	2-1/4	6-1/8	14-1/4	2-3/8	1-1/16	1/2	1-3/16	—	1/2	9-3/4	14-3/4				
	19226L	1 - 300								1-3/16					11-1/4	16-1/4				
1-1/2	19357L	1-1/2 - 150	2	2 - 150	7-1/8	3-1/8	6-1/8	18-1/8	3-5/8	1-3/16	1/2	1-3/8	—	5/8	22-3/4	30-1/4				
	19357L	1-1/2 - 300								1-5/16					26-1/4	33-3/4				
2	19567L	2 - 150	2-1/2	2-1/2 - 150	7-1/8	3-1/8	6-1/8	18-1/8	3-5/8	1-3/8	5/8	1-1/2	—	5/8	26-3/4	38-1/4				
	19567L	2 - 300								1-1/2					28-3/4	40-1/4				
1/2	19096M 19110M	1/2 - 300	1	1 - 150	6	2	4-7/8	14-15/16	2-9/16	1	7/16	1-1/16	—	1/2	9	12				
		1/2 - 600		1 - 150				6		14-15/16					1	7/16	1-1/16	—	9	12
		1/2 - 900		1 - 300				6-1/2		15-7/16					1-1/2	5/8	—	1-3/16	13-1/4	17-3/4
		1/2 - 1500		1 - 300				6-1/2		15-7/16					1-1/2	5/8	—	1-3/16	13-1/4	17-3/4
3/4	19096M 19110M	3/4 - 300	1	1 - 150	6-1/4	2	4-7/8	15-3/16	2-9/16	1-1/8	1/2	1-1/16	—	1/2	10-1/4	13-1/4				
		3/4 - 600		1 - 150				6-1/4		15-3/16					1-1/8	1/2	1-1/16	—	10-1/4	13-1/4
		3/4 - 900		1 - 300				6-3/4		15-11/16					1-5/8	5/8	—	1-3/16	13-1/2	18
		3/4 - 1500		1 - 300				6-3/4		15-11/16					1-5/8	5/8	—	1-3/16	13-1/2	18
1	19096M 19110M	1 - 300	1	1 - 150	6-1/2	2	4-7/8	15-7/16	2-9/16	1-3/16	1/2	1-1/16	—	1/2	11	14				
		1 - 600		1 - 150				6-1/2		15-7/16					1-3/16	1/2	1-1/16	—	11	14
		1 - 900		1 - 300				7-1/2		16-7/16					1-3/4	5/8	—	1-3/16	15-1/2	20
		1 - 1500		1 - 300				7-1/2		16-7/16					1-3/4	5/8	—	1-3/16	15-1/2	20
3/4	19126M	3/4 - 300	1	1 - 150	6-1/4	2	4-7/8	15-3/16	2-9/16	1-1/8	1/2	1-1/16	—	1/2	10-1/4	13-1/4				
		3/4 - 600		1 - 150				6-1/4		15-3/16					1-1/8	1/2	1-1/16	—	10-1/4	13-1/4
		3/4 - 900		1 - 300				6-3/4		15-11/16					1-5/8	5/8	—	1-3/16	13-1/2	18
		3/4 - 1500		1 - 300				6-3/4		15-11/16					1-5/8	5/8	—	1-3/16	13-1/2	18
1	19126M	1 - 300	1	1 - 150	6-1/2	2	4-7/8	15-7/16	2-9/16	1-3/16	1/2	1-1/16	—	1/2	11	14				
		1 - 600		1 - 150				6-1/2		15-7/16					1-3/16	1/2	1-1/16	—	11	14
		1 - 900		1 - 300				7-1/2		16-7/16					1-3/4	5/8	—	1-3/16	15-3/4	20-1/4
		1 - 1500		1 - 300				7-1/2		16-7/16					1-3/4	5/8	—	1-3/16	15-3/4	20-1/4

19000 Flanged Connections (Inches & Pounds)

Size (in.)	Type	Inlet (RF or RJ) ANSI Standard Except Thickness	Outlet		A (in.)	B (in.)		C (in.)	D (in.)	E (in.)	F (in.)	G (in.)		H (in.)	Approx. Weight (lbs.)					
			Female NPT (in.)	(RF or RJ) ANSI Standard Except Thickness		NPT (in.)	Flange (in.)					RF or RJ	RF or RJ		Class 150#	Class 300#	Threaded Outlet	Flanged Outlet		
															RF or RJ	RF or RJ				
1	19226M	1 - 300	1-1/2	1-1/2 - 150	6-1/4	2-3/8	6-1/8	15-5/8	3-1/8	1-3/16	1/2	1-3/16	—	1/2	16	21				
		1 - 600		1-1/2 - 150	6-1/4			15-5/8							1-3/16	1/2	1-3/16	16	21	
		1 - 900		1-1/2 - 300	7-1/4			16-5/8							1-3/4	5/8	—	1-5/16	20-1/2	29
		1 - 1500		1-1/2 - 300	7-1/4			16-5/8							1-3/4	5/8	—	1-5/16	20-1/2	29
1-1/2	19357M	1-1/2 - 300	2	2 - 150	7-1/8	3-1/8	6-1/8	19-15/16	4-5/8	1-5/16	1/2	1-3/8	—	5/8	38-1/4	45-3/4				
		1-1/2 - 600		2 - 150	7-1/8			19-15/16							1-3/8	1/2	1-3/8	38-1/4	45-3/4	
		1-1/2 - 900		2 - 300	8-1/4			21-1/16							1-7/8	5/8	—	1-1/2	46-3/4	56-1/4
		1-1/2 - 1500		2 - 300	8-1/4			21-1/16							1-7/8	5/8	—	1-1/2	46-3/4	56-1/4
2	19567M	2 - 300	2-1/2	2-1/2 - 150	7-1/8	3-1/8	6-1/8	19-15/16	4-5/8	1-1/2	—	1-1/2	—	5/8	39-3/4	51-1/4				
		2 - 600		2-1/2 - 150	7-1/8			19-15/16							1-5/8	—	—	40-3/4	52-1/4	
		2 - 900		2-1/2 - 300	8-1/4			21-1/16							2-1/8	—	1-5/8	55-1/4	68-3/4	
		2 - 1500		2-1/2 - 300	8-1/4			21-1/16							2-1/8	—	1-5/8	55-1/4	68-3/4	
3/4	19096H/ 19110H	3/4 - 1500	1	1 - 300	6-1/2	2-3/8	6-1/4	15-5/8	3-1/8	1-5/8	5/8	—	1-3/16	1/2	18-1/2	23				
		3/4 - 2500						15-5/8							1-7/8	—	1-3/16	20-3/4	25-1/4	
3/4	19126H	3/4 - 1500	1	1 - 300	6-1/2	3-1/8	6-1/4	19-1/16	4-5/8	1-5/8	5/8	—	1-3/16	1/2	37	41-1/2				
		3/4 - 2500						19-1/16							1-7/8	—	1-3/16	39	43-1/2	
1	19226H	1 - 1500	1-1/2	1-1/2 - 300	7-1/4	3-1/8	6-1/8	16-3/8	4-5/8	1-3/4	5/8	—	1-5/16	1/2	39	47				
		1 - 2500						16-3/8							2	—	1-5/16	43-1/2	51-1/2	

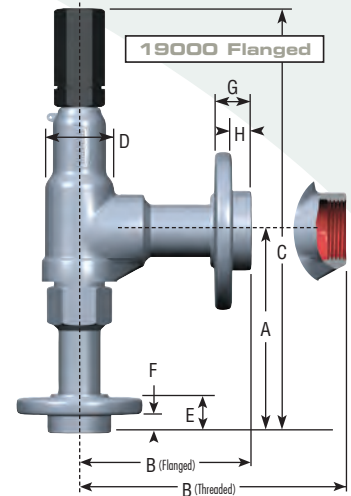

19096MBP Flanged Connections (Inches & Pounds)

Size (in.)	Type	Inlet (RF or RJ) ANSI Standard Except Thickness	Outlet		A (in.)	B (in.)		C (in.)	D (in.)	E (in.)	F (in.)	G (in.)		H (in.)	Approx. Weight (lbs.)					
			Female NPT (in.)	(RF or RJ) ANSI Standard Except Thickness		NPT (in.)	Flange (in.)					RF or RJ	RF or RJ		Class 150#	Class 300#	Threaded Outlet	Flanged Outlet		
															RF or RJ	RF or RJ				
1/2	19096M	1/2 - 150	1	1 - 150	6	2	4-7/8	15-5/8	3-3/4	7/8	7/16	1-1/16	—	1/2	13	16				
		1/2 - 300		1 - 150	6			15-5/8							1	7/16	1-1/16	14	17	
		1/2 - 600		1 - 150	6			15-5/8							1	7/16	1-1/16	14	17	
		1/2 - 900		1 - 300	6-1/2			16-1/8							1-1/2	5/8	—	1-3/16	18-1/4	22-3/4
		1/2 - 1500		1 - 300	6-1/2			16-1/8							1-1/2	5/8	—	1-3/16	18-1/4	22-3/4
3/4	19096M	3/4 - 150	1	1 - 150	6-1/4	2	4-7/8	15-7/8	3-3/4	1-1/8	1/2	1-1/16	—	1/2	13-3/4	16-3/4				
		3/4 - 300		1 - 150	6-1/4			15-7/8							1-1/8	1/2	1-1/16	15-1/4	18-1/4	
		3/4 - 600		1 - 150	6-1/4			15-7/8							1-1/8	1/2	1-1/16	15-1/4	18-1/4	
		3/4 - 900		1 - 300	6-3/4			16-3/8							1-5/8	5/8	—	1-3/16	20	23
1	19096M	1 - 1500	1	1 - 300	6-3/4	2	4-7/8	16-3/8	3-3/4	1-5/8	5/8	—	1-3/16	1/2	20	23				
		1 - 150		1 - 150	6-1/2			16-1/8							1-1/16	1/2	1-1/16	14-1/2	17-1/2	
		1 - 300		1 - 150	6-1/2			16-1/8							1-3/16	1/2	1-1/16	16	19	
		1 - 600		1 - 150	6-1/2			16-1/8							1-3/16	1/2	1-1/16	16	19	
		1 - 900		1 - 300	7-1/2			17-1/8							1-3/4	5/8	—	1-3/16	22	25
1 - 1500	1 - 300	7-1/2	17-1/8	1-3/4	5/8	—	1-3/16	22	25											

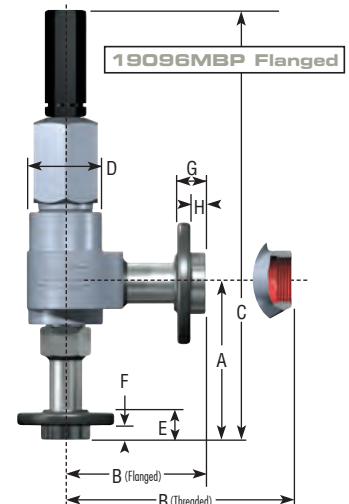

19000 Flanged Connections (Millimeters & Kilograms)

Size (in.)	Type	Inlet (RF or RJ) ANSI Standard Except Thickness	Outlet		A (mm)	B (mm)		C (mm)	D (mm)	E (mm)	F (mm)	G		H (mm)	Approx. Weight							
			Female NPT (in.)	(RF or RJ) ANSI Standard Except Thickness		NPT (mm)	Flange (mm)					Class 150#	Class 300#		RF or RJ	RF or RJ	RF or RJ	RF or RJ	Threaded Outlet	Flanged Outlet		
																					(mm)	(mm)
1/2	19096L	1/2 - 150	1	1 - 150	152.4	47.6	123.8	333.4	50.8	22.2	11.1	27.0	—	12.7	2.8	4.2						
	19110L	1/2 - 300													3.3	4.6						
3/4	19096L	3/4 - 150	1	1 - 150	158.8	47.6	123.8	339.7	50.8	25.4	12.7	27.0	—	12.7	3.2	4.5						
	19110L	3/4 - 300													3.9	5.2						
1	19096L	1 - 150	1	1 - 150	165.1	47.6	123.8	346.1	50.8	27.0	12.7	27.0	—	12.7	3.5	4.9						
	19110L	1 - 300													4.2	5.6						
3/4	19126L	3/4 - 150	1	1 - 150	158.8	47.6	123.8	339.7	50.8	25.4	12.7	27.0	—	12.7	3.4	4.8						
	19126L	3/4 - 300													4.1	5.4						
1	19126L	1 - 150	1	1 - 150	165.1	47.6	123.8	346.1	50.8	30.2	12.7	27.0	—	12.7	3.7	5.1						
	19126L	1 - 300													4.4	5.8						
1	19226L	1 - 150	1-1/2	1-1/2 - 150	158.8	57.2	155.6	362.0	60.3	27.0	12.7	30.2	—	12.7	4.4	6.7						
	19226L	1 - 300													5.1	7.4						
1-1/2	19357L	1-1/2 - 150	2	2 - 150	181.0	79.4	155.6	460.4	92.1	30.2	12.7	34.9	—	15.9	10.3	13.7						
	19357L	1-1/2 - 300													11.9	15.3						
2	19567L	2 - 150	2-1/2	2-1/2 - 150	181.0	79.4	155.6	460.4	92.1	34.9	15.9	38.1	—	15.9	12.1	17.4						
	19567L	2 - 300													13.0	18.3						
1/2	19096M 19110M	1/2 - 300	1	1 - 150	152.4	50.8	123.8	379.4	65.1	25.4	11.1	27.0	—	12.7	4.1	5.4						
		1/2 - 600		1 - 150											152.4	379.4	25.4	11.1	27.0	—	4.1	5.4
		1/2 - 900		1 - 300											165.1	392.1	38.1	15.9	—	30.2	6.0	8.1
		1/2 - 1500		1 - 300											165.1	392.1	38.1	15.9	—	30.2	6.0	8.1
3/4	19096M 19110M	3/4 - 300	1	1 - 150	158.8	50.8	123.8	385.8	65.1	28.6	12.7	27.0	—	12.7	4.6	6.0						
		3/4 - 600		1 - 150											158.8	385.8	28.6	12.7	27.0	—	4.6	6.0
		3/4 - 900		1 - 300											171.5	398.5	41.3	15.9	—	30.2	6.1	8.2
		3/4 - 1500		1 - 300											171.5	398.5	41.3	15.9	—	30.2	6.1	8.2
1	19096M 19110M	1 - 300	1	1 - 150	165.1	50.8	123.8	392.1	65.1	30.2	12.7	27.0	—	12.7	5.0	6.4						
		1 - 600		1 - 150											165.1	392.1	30.2	12.7	27.0	—	5.0	6.4
		1 - 900		1 - 300											190.5	417.5	44.5	15.9	—	30.2	7.0	9.1
		1 - 1500		1 - 300											190.5	417.5	44.5	15.9	—	30.2	7.0	9.1
3/4	19126M	3/4 - 300	1	1 - 150	158.8	50.8	123.8	385.8	65.1	28.6	12.7	27.0	—	12.7	4.6	6.0						
		3/4 - 600		1 - 150											158.8	385.8	28.6	12.7	27.0	—	4.6	6.0
		3/4 - 900		1 - 300											171.5	398.5	41.3	15.9	—	30.2	6.1	8.2
		3/4 - 1500		1 - 300											171.5	398.5	41.3	15.9	—	30.2	6.1	8.2
1	19126M	1 - 300	1	1 - 150	165.1	50.8	123.8	392.1	65.1	30.2	12.7	27.0	—	12.7	5.0	6.4						
		1 - 600		1 - 150											165.1	392.1	30.2	12.7	27.0	—	5.0	6.4
		1 - 900		1 - 300											190.5	417.5	44.5	15.9	—	30.2	7.1	9.2
		1 - 1500		1 - 300											190.5	417.5	44.5	15.9	—	30.2	7.1	9.2

19000 Flanged Connections (Millimeters & Kilograms)

Size (in.)	Type	Inlet (RF or RJ) ANSI Standard Except Thickness	Outlet		A (mm)	B (mm)		C (mm)	D (mm)	E (mm)	F (mm)	G (mm)		H (mm)	Approx. Weight (Kg)					
			Female NPT (in.)	(RF or RJ) ANSI Standard Except Thickness		NPT (mm)	Flange (mm)					Class 150#	Class 300#		RF or RJ	RF or RJ	RF or RJ	RF or RJ	Threaded Outlet	Flanged Outlet
1	19226M	1 - 300	1-1/2	1-1/2 - 150	158.8	60.3	155.6	396.9	79.4	30.2	12.7	30.2	—	12.7	7.3	9.5				
		1 - 600		1-1/2 - 150	158.8			396.9		30.2	12.7	30.2	—		7.3	9.5				
		1 - 900		1-1/2 - 300	184.2			422.3		44.5	15.9	—	33.3		9.3	13.2				
		1 - 1500		1-1/2 - 300	184.2			422.3		44.5	15.9	—	33.3		9.3	13.2				
1-1/2	19357M	1-1/2 - 300	2	2 - 150	181.0	79.4	155.6	506.4	117.5	33.3	12.7	34.9	—	15.9	17.4	20.8				
		1-1/2 - 600		2 - 150	181.0			506.4		34.9	12.7	34.9	—		17.4	20.8				
		1-1/2 - 900		2 - 300	209.6			535.0		47.6	15.9	—	38.1		21.2	25.5				
		1-1/2 - 1500		2 - 300	209.6			535.0		47.6	15.9	—	38.1		21.2	25.5				
2	19567M	2 - 300	2-1/2	2-1/2 - 150	181.0	79.4	155.6	506.4	117.5	38.1	15.9	38.1	—	15.9	18.0	23.2				
		2 - 600		2-1/2 - 150	181.0			506.4		41.3	15.9	38.1	—		18.5	23.7				
		2 - 900		2-1/2 - 300	209.6			535.0		54.0	15.9	—	41.3		25.1	31.2				
		2 - 1500		2-1/2 - 300	209.6			535.0		54.0	15.9	—	41.3		25.1	31.2				
3/4	19096H/19110H	3/4 - 1500	1	1 - 300	165.1	60.3	158.8	396.9	79.4	41.3	15.9	—	30.2	12.7	8.4	10.4				
		3/4 - 2500			165.1			60.3		158.8	396.9	47.6	15.9		—	30.2	9.4	11.5		
3/4	19126H	3/4 - 1500	1	1 - 300	165.1	79.4	158.8	484.2	114.3	41.3	15.9	—	30.2	12.7	16.8	18.8				
		3/4 - 2500			165.1			79.4		158.8	484.2	47.6	15.9		—	30.2	17.7	19.7		
1	19226H	1 - 1500	1-1/2	1-1/2 - 300	184.2	79.4	155.6	415.9	114.3	44.5	15.9	—	33.3	12.7	17.7	21.3				
		1 - 2500			184.2			79.4		155.6	415.9	50.8	15.9		—	33.3	19.7	23.4		

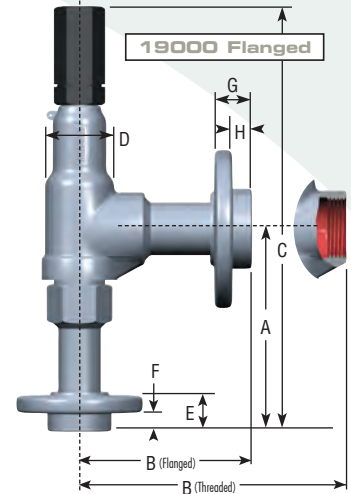

19096MBP Flanged Connections (Millimeters & Kilograms)

Size (in.)	Type	Inlet (RF or RJ) ANSI Standard Except Thickness	Outlet		A (mm)	B (mm)		C (mm)	D (mm)	E (mm)	F (mm)	G (mm)		H (mm)	Approx. Weight (Kg)					
			Female NPT (in.)	(RF or RJ) ANSI Standard Except Thickness		NPT (mm)	Flange (mm)					Class 150#	Class 300#		RF or RJ	RF or RJ	RF or RJ	RF or RJ	Threaded Outlet	Flanged Outlet
1/2	19096M	1/2 - 150	1	1 - 150	152.4	50.8	123.8	396.9	95.3	22.2	11.1	27.0	—	12.7	5.9	7.3				
		1/2 - 300		1 - 150	152.4			396.9		25.4	11.1	27.0	—		6.4	7.7				
		1/2 - 600		1 - 150	152.4			396.9		25.4	11.1	27.0	—		6.4	7.7				
		1/2 - 900		1 - 300	165.1			409.6		38.1	15.9	—	30.2		8.3	10.3				
		1/2 - 1500		1 - 300	165.1			409.6		38.1	15.9	—	30.2		8.3	10.3				
3/4	19096M	3/4 - 150	1	1 - 150	158.8	50.8	123.8	403.2	95.3	25.4	12.7	27.0	—	12.7	6.2	7.6				
		3/4 - 300		1 - 150	158.8			403.2		28.6	12.7	27.0	—		6.9	8.3				
		3/4 - 600		1 - 150	158.8			403.2		28.6	12.7	27.0	—		6.9	8.3				
		3/4 - 900		1 - 300	171.5			415.9		41.3	15.9	—	30.2		9.1	10.4				
		3/4 - 1500		1 - 300	171.5			415.9		41.3	15.9	—	30.2		9.1	10.4				
1	19096M	1 - 150	1	1 - 150	165.1	50.8	123.8	409.6	95.3	27.0	12.7	27.0	—	12.7	6.5	7.9				
		1 - 300		1 - 150	165.1			409.6		30.2	12.7	27.0	—		7.3	8.6				
		1 - 600		1 - 150	165.1			409.6		30.2	12.7	27.0	—		7.3	8.6				
		1 - 900		1 - 300	190.5			435.0		44.5	15.9	—	30.2		10.0	11.3				
		1 - 1500		1 - 300	190.5			435.0		44.5	15.9	—	30.2		10.0	11.3				

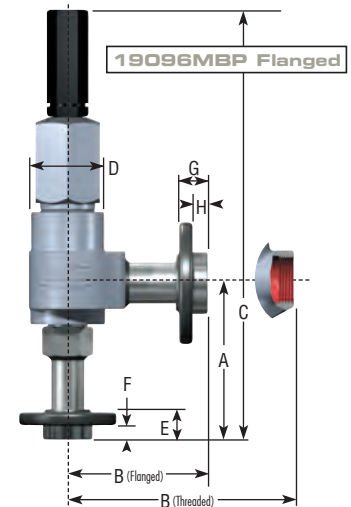

O-Ring Selection Procedure

In addition to the rating of the valve based on materials and temperatures, it is possible that if the valve is equipped with O-Rings (soft seats), the O-Ring may limit the range of valve application.

The following selection process is simple and straight forward and should yield a satisfactory valve selection.

Use the following steps in the O-Ring selection process:

1. Refer to the Technical Information section in this catalog to select appropriate O-Ring material for service media.

2. Refer to "Table A" (O-Ring Selection - Durometer). Using the valve set pressure, determine the durometer hardness which will be needed.

3. Refer to "Table B". Utilizing the material selected and the durometer hardness selected check the temperature limits of the material.

4. If the selected material is not adequate, select another material and repeat the procedure.

NOTE: For fire applications use the operating temperature when selecting a material.

**O-Ring Selection - Durometer
Table A**

Valve Type	O-Ring Durometer			Teflon	
	50 ¹ Set Press. (psig)	70 ¹ Set Press. (psig)	90 ² Set Press. (psig)	-300 to 200°F Set Press. (psig)	201 to 500°F Set Press. (psig)
19096	15 to 300	100 to 500	300 to 2500	1400 to 5000	15 to 5000
19110	15 to 300	100 to 500	300 to 2500	1400 to 5000	15 to 5000
19126	15 to 250	30 to 500	250 to 2250	1000 to 6000	15 to 6000
19226	15 to 200	15 to 450	200 to 2000	1000 to 6000	15 to 6000
19357	15 to 150	15 to 400	150 to 1500	—	15 to 1500
19567	15 to 150	15 to 400	100 to 1000	—	15 to 1000

NOTES: 1 Maximum set pressure for silicone compounds is half of the maximum value.

2 The E9 62-90D O-Ring can be used in steam service to a lower pressure limit of 15 psig.

**O-Ring Temperature Limits
Table B**

Material	Durometer	Description	Temperature Limits	
			°F	°C
Nitrile	50	N299-50 OR N1009-50	-45 to +225°	-43 to +107°
	70	N674-70	-40 to +250°	-40 to +121°
	90	N552-90	-40 to +350°	-40 to +177°
	70 ⁴	N1173-70	-25 to +300°	-31 to +149°
Ethylene/Propylene	50	E981-50	-65 to +212°	-53 to +100°
	70	E603-70	-65 to +212°	-53 to +100°
	75 & 80 ²	E740-75 & E515-80	-70 to +250°	-57 to +121°
	90	E962-90 ¹	-70 to +500°	-57 to +260°
Fluorocarbon	75	E962-75	-60 to +250/400°	-51 to +121/204°
	50	V986-50	-15 to +400°	-26 to +204°
	75	V747-75 OR V884-75	-15 to +400°	-26 to +204°
Neoprene	90	V894-90 OR V709-90	-15 to +400°	-26 to +204°
	50	C267-50	-45 to +300°	-43 to +149°
Silicone	70	C944-70 OR C873-70	-45 to +300°	-43 to +149°
	50	S595-50	-65 to +437°	-53 to +225°
Teflon	70	S604-70	-65 to +437°	-53 to +225°
	N/A	Teflon	-300 to +500°	-184 to +260°
Kalrez ³	82	1050LF	-42 to +550°	-41 to +288°
Kalrez ³	75	4079	-58 to +600°	-50 to +315°
Kalrez ³	91	3018	-35 to +550°	-37 to +288°
Kalrez ³	65	1058	-40 to +500°	-40 to +260°

NOTES: 1 EPR962-90D can be used in steam service to a lower pressure limit of 15 psig.

2 Set Pressure Ranges per "Table B" For durometer shall apply to these compounds (For Nuclear Service, Radiation Environment.)

3 Consult Factory before selecting. (4079 - Not for use in hot water or steam applications.)

4 Consult Factory before using. For use with Freon 134A/Ester Oil Service.

General Information

19000 & 19096MBP Series

These ratings apply to threaded or socket weld end connections.

When the valves are supplied with flanged connections the flange ratings may govern the range of valve pressure/temperature rating.

When selecting valves for back pressure applications the following limits apply:

- Constant back pressure - 400 psig
- Variable back pressure (superimposed or built-up) - 400 psig or 10% of set pressure whichever is smaller.

Valves with set pressures less than 15 psig cannot be stamped with the ASME Code stamp.

NOTE: When soft seats are used Elastomer material may govern the valve pressure/temperature rating.



Pressure / Temperature Rating of 19000 Series Valves

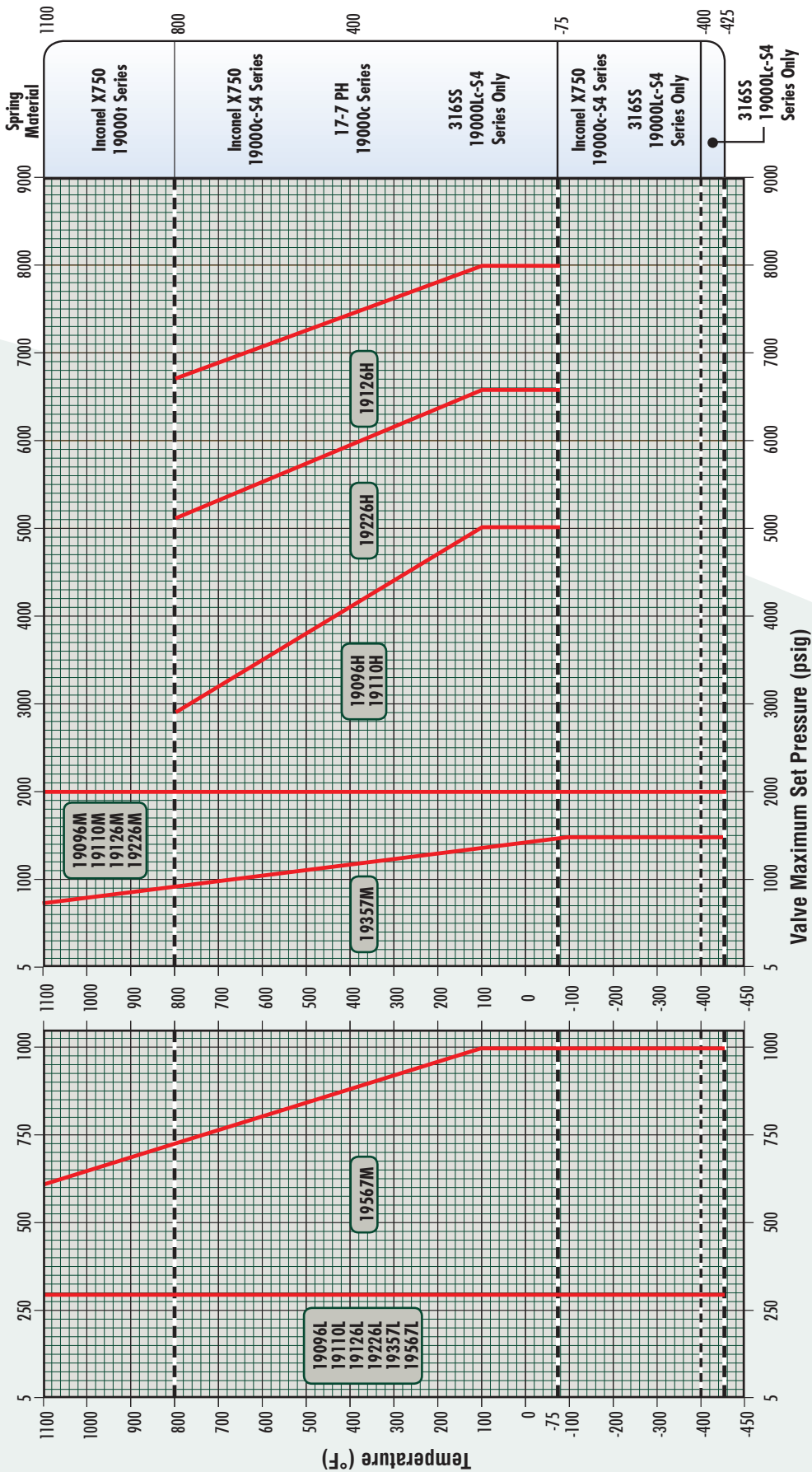

ORIFICE CAPACITIES - AIR
(USCS Units) ASME B & PVC, Section VIIISet Pressure plus 10% overpressure or 3 psig,
whichever is greater. SCFM Air @ 60°F.

Set Press. (psig)	Orifice Area (Sq. in.)					
	19096 & MBP .096 ¹	19110 .110	19126 .126	19226 .226	19357 .357	19567 .567
15	51	58	66	119	188	299
20	58	66	77	137	217	344
30	74	84	97	174	274	436
40	91	104	119	214	338	536
50	108	123	142	254	401	637
60	125	143	164	294	464	737
70	142	162	186	334	528	838
80	159	182	209	374	591	938
90	176	201	231	414	654	1039
100	193	221	253	454	717	1139
120	227	260	298	534	844	1340
140	261	299	343	614	971	1541
160	295	338	387	695	1097	1743
180	329	377	432	775	1224	1944
200	363	416	477	855	1350	2145
220	397	455	521	935	1477	2346
240	431	494	566	1015	1603	2547
260	465	533	611	1095	1730	2748
280	499	572	655	1175	1857	2949
300	533	611	700	1255	1983	3150
320	567	650	745	1336	2110	3351
340	601	689	789	1416	2236	3552
360	635	728	834	1496	2363	3753
380	669	767	879	1576	2489	3954
400	704	806	923	1656	2616	4155
420	737	845	968	1736	2743	4356
440	772	884	1013	1816	2869	4557
460	806	923	1057	1896	2996	4758
480	840	962	1102	1977	3122	4959
500	874	1001	1147	2057	3249	5160
600	1044	1196	1370	2457	3882	6165
700	1214	1391	1593	2858	4514	7170
750	1299	1489	1705	3058	4831	7673
800	1384	1586	1817	3259	5147	8175
900	1554	1781	2040	3659	5780	9180
1000	1725	1976	2264	4060	6413	10186
1100	1895	2171	2487	4460	7046	-
1200	2065	2366	2710	4861	7679	-
1300	2235	2561	2934	5262	8312	-
1400	2405	2756	3157	5662	8945	-
1500	2575	2951	3380	6063	9577	-
1600	2745	3146	3603	6463	-	-
1700	2915	3341	3827	6864	-	-
1800	3086	3536	4050	7264	-	-
1900	3256	3731	4273	7665	-	-
2000	3426	3926	4497	8066	-	-
2500	4277	4901	5614	10069	-	-
3000	5128	5876	6731	12072	-	-
3500	5979	6851	7848	14076	-	-
4000	6830	7826	8964	16078	-	-
4500	7681	8801	10081	18082	-	-
5000	8532	9776	11198	20085	-	-
5500	-	-	12315	22088	-	-
6000	-	-	13432	24091	-	-
6400	-	-	14325	25694	-	-
6500	-	-	14548	-	-	-
7000	-	-	15665	-	-	-
7500	-	-	16782	-	-	-
8000	-	-	17899	-	-	-

SIZING: Refer to the sizing section for formulas for both ASME and API sizing. Valves may be sized for either ASME or API applications.
NOTE 1: 19096MBP set pressure limit 50 to 2000 psig.

ORIFICE CAPACITIES - STEAM
(USCS Units) ASME B & PVC, Section VIII

Set Pressure plus 10% overpressure
or 3 psig, whichever is greater,
lbs. per hour saturated steam

Set Press. (psig)	Orifice Area (Sq. in.)					
	19096 & MBP .096 ¹	19110 .110	19126 .126	19226 .226	19357 .357	19567 .567
15	142	162	186	334	527	838
20	164	187	215	385	609	967
30	207	237	272	487	770	1223
40	255	292	334	600	948	1505
50	303	346	397	712	1125	1787
60	350	401	460	825	1303	2069
70	398	456	522	937	1480	2351
80	446	510	585	1049	1658	2633
90	494	565	648	1162	1835	2915
100	541	620	710	1274	2013	3197
120	637	729	836	1499	2368	3761
140	732	839	961	1724	2723	4325
160	828	948	1086	1949	3078	4889
180	923	1057	1212	2174	3434	5453
200	1019	1167	1337	2398	3789	6017
220	1114	1276	1463	2623	4144	6581
240	1210	1386	1588	2848	4499	7145
260	1305	1495	1713	3073	4854	7709
280	1401	1605	1839	3298	5209	8273
300	1496	1714	1964	3523	5564	8837
320	1592	1824	2089	3747	5919	9401
340	1687	1933	2215	3972	6275	9966
360	1783	2043	2340	4197	6630	10530
380	1878	2152	2465	4422	6985	11094
400	1974	2262	2591	4647	7340	11658
420	2069	2371	2716	4871	7695	12222
440	2165	2480	2841	5096	8050	12786
460	2260	2590	2967	5321	8405	13350
480	2356	2699	3092	5546	8761	13914
500	2451	2809	3217	5771	9116	14478
600	2929	3356	3844	6895	10891	17298
700	3406	3903	4471	8019	12667	20118
750	3645	4177	4784	8581	13555	21528
800	3884	4450	5097	9143	14443	22938
900	4361	4997	5724	10267	16218	25759
1000	4839	5544	6351	11391	17994	28579
1100	5316	6091	6978	12515	19770	-
1200	5794	6639	7604	13639	21545	-
1300	6271	7186	8230	14763	23321	-
1400	6748	7733	8857	15887	25096	-
1423	6858	7859	9002	16146	25505	-
1500	7261	8320	9530	17093	27001	-
1600	7792	8928	10227	18343	-	-
1700	8334	9549	10938	19619	-	-
1800	8888	10184	11665	20923	-	-
1900	9455	10835	12410	22260	-	-
2000	10039	11503	13176	23634	-	-
2500	13285	15222	17437	31275	-	-
2903*	16611	19034	21803	39106	-	-

* 2903 psig is maximum allowable set pressure for steam. 3000 psig capacities are provided for interpolation purposes only.
SIZING: Refer to the sizing section for formulas for both ASME and API sizing. Valves may be sized for either ASME or API applications.
NOTE 1: 19096MBP set pressure limit 50 to 1528 psig saturated steam.

ORIFICE CAPACITIES - WATER
(USCS Units) ASME B & PVC, Section VIII

Set Pressure plus 10% overpressure
or 3 psig, whichever is greater,
zero psig back pressure, GPM water @ 70°F.

Set Press. (psig)	Orifice Area (Sq. in.)					
	19096 & MBP .096 ¹	19110 .110	19126 .126	19226 .226	19357 .357	19567 .567
15	10	11	14	25	39	62
20	12	13	15	28	44	70
30	14	16	19	33	52	83
40	16	18	21	38	61	96
50	18	20	24	43	68	108
60	20	22	26	47	74	118
70	22	24	28	51	80	127
80	23	26	30	54	86	136
90	24	28	32	58	91	144
100	26	29	34	61	96	152
120	28	32	37	66	105	167
140	30	34	40	72	113	180
160	33	37	43	77	121	192
180	35	39	45	81	128	201
200	36	41	48	86	135	215
220	38	43	50	90	142	226
240	40	45	52	94	148	236
260	42	47	54	98	154	245
280	43	49	57	101	160	254
300	45	51	59	105	166	263
320	46	52	60	108	171	272
340	47	54	62	112	177	280
360	49	56	64	115	182	289
380	50	57	66	118	187	296
400	51	59	68	121	192	304
420	53	60	69	124	196	312
440	54	62	71	127	201	319
460	55	63	72	130	205	326
480	56	64	74	133	210	333
500	58	66	76	136	214	340
600	63	72	83	148	235	373
700	68	78	89	160	253	402
750	71	81	93	166	262	416
800	73	83	96	171	271	430
900	77	89	101	182	287	456
1000	81	93	107	192	303	481
1100	85	98	112	201	318	-
1200	89	102	117	210	332	-
1300	93	106	122	219	345	-
1400	96	110	126	227	358	-
1500	100	114	131	235	371	-
1600	103	118	135	242	-	-
1700	106	122	139	249	-	-
1800	109	125	143	257	-	-
1900	112	129	147	264	-	-
2000	115	132	151	271	-	-
2500	129	148	169	303	-	-
3000	141	162	185	332	-	-
3500	152	175	200	359	-	-
4000	163	187	214	383	-	-
4500	173	199	227	407	-	-
5000	182	208	239	429	-	-
5500	-	-	251	450	-	-
6000	-	-	262	470	-	-
6400	-	-	270	485	-	-
6500	-	-	272	-	-	-
7000	-	-	283	-	-	-
7500	-	-	293	-	-	-
8000	-	-	302	-	-	-

SIZING: Refer to the sizing section for formulas for both ASME and API sizing. Valves may be sized for either ASME or API applications.
NOTE 1: 19096MBP set pressure limit 50 to 2000 psig.