



## 1982 Series

Consolidated® Safety Relief Valve





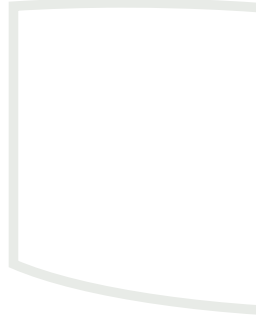

# Table of Contents

---

Conversion Table . . . . .	1982.2
Features & Benefits . . . . .	1982.3
Scope of Design . . . . .	1982.3
Materials . . . . .	1982.4
1982 Standard Materials . . . . .	1982.5
1982 Optional Materials . . . . .	1982.6
Dimensions & Weights . . . . .	1982.11
Pressure / Temperature . . . . .	1982.14
Capacities . . . . .	1982.15
Valve Configuration Code . . . . .	1982.18
How to Order a 1982 SRV . . . . .	1982.20



# Conversion Table

All the USCS values are converted to Metric values using the following conversion factors:

USCS Unit	Conversion Factor	Metric Unit
in.	25.4	mm
lb.	0.4535924	kg
in <sup>2</sup>	6.4516	cm <sup>2</sup>
ft <sup>3</sup> /min	0.02831685	m <sup>3</sup> /min
gal/min	3.785412	L/min
lb/hr	0.4535924	kg/hr
psig	0.06894757	barg
ft lb	1.3558181	Nm
°F	5/9 (°F-32)	°C



The Consolidated Type 1982 Safety Relief Valve is an ASME B & PVC, Section VIII certified threaded connection pressure relief valve for vapor and steam service applications.

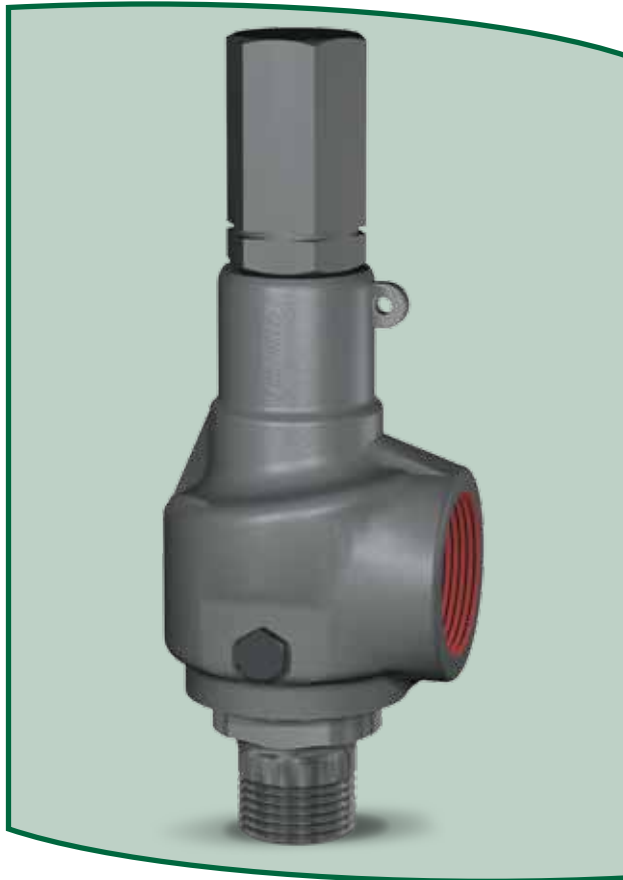

- INLET SIZES** .5" (12.7 mm) through 2" (50.8 mm)
- OUTLET SIZES** .75" (19.1 mm) through 2.5" (63.5 mm)
- INLET RATINGS** ANSI Class 150 and 300
- OUTLET RATINGS** ANSI Class 150
- ORIFICE SIZES** Five sizes: 1/2, 3/4, 1, 1-1/2 and 2.
- PRESSURE RANGE** 10 psig (0.69 barg) to 500 psig (34.47 barg)
- TEMPERATURE RANGE** -20°F (-29°C) to 800°F (427°C)
- MATERIALS** Carbon steel base and 316 stainless steel internal components.
- CERTIFICATIONS**
  - ASME B & PVC, Section III
  - ASME B & PVC, Section VIII, Division I

## Features & Benefits

The 1982 Series Safety Relief Valves are designed and manufactured in compliance with ASME B & PVC, Section VIII and Section III (Class I, II and III). Mainly used for steam and liquid applications.

## Scope of Design

This product is normally supplied with threaded inlet and outlet connections. The valve ranges in inlet sizes from .50" (12.7 mm) through 2.00" (50.8 mm). Maximum pressure setting is 500 psig (34.47 barg), minimum pressure setting is 10 psig (0.69 barg). This valve is available with a screwed cap, packed lever, plain lever and gag. Unless otherwise specified, the valve is shipped with a screwed cap. The 2.00" (50.8 mm) 1982 valve can be used for all service media except steam service above 100 psig (6.89 barg).

1982 Standard Connections								
Valve Type	Inlet Size		Inlet Type	Outlet Size		Outlet Type	Orifice Area	
	in.	mm		in.	mm		in <sup>2</sup>	cm <sup>2</sup>
1/2-1982	.50	12.7	MNPT	.75	19.1	FNPT	0.121	0.781
3/4-1982	.75	19.1	MNPT	1.00	25.4	FNPT	0.216	1.394
1-1982	1.00	25.4	MNPT	1.50	38.1	FNPT	0.332	2.142
1-1/2-1982	1.50	38.1	MNPT	2.00	50.8	FNPT	0.857	5.529
2-1982	2.00	50.8	MNPT	2.50	63.5	FNPT	1.399	9.026

# Materials

## 1982 Type Main Valve

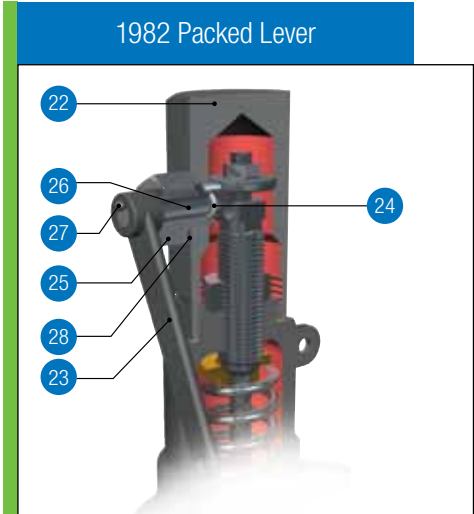
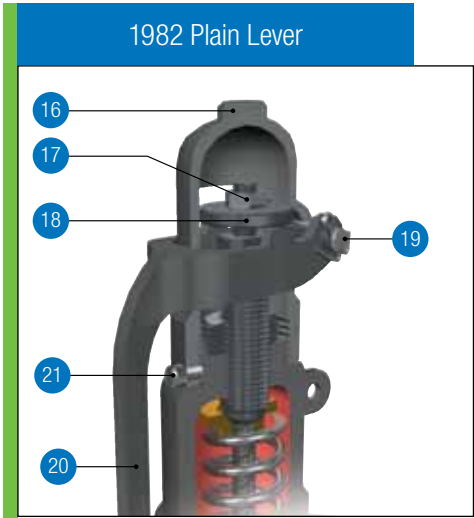
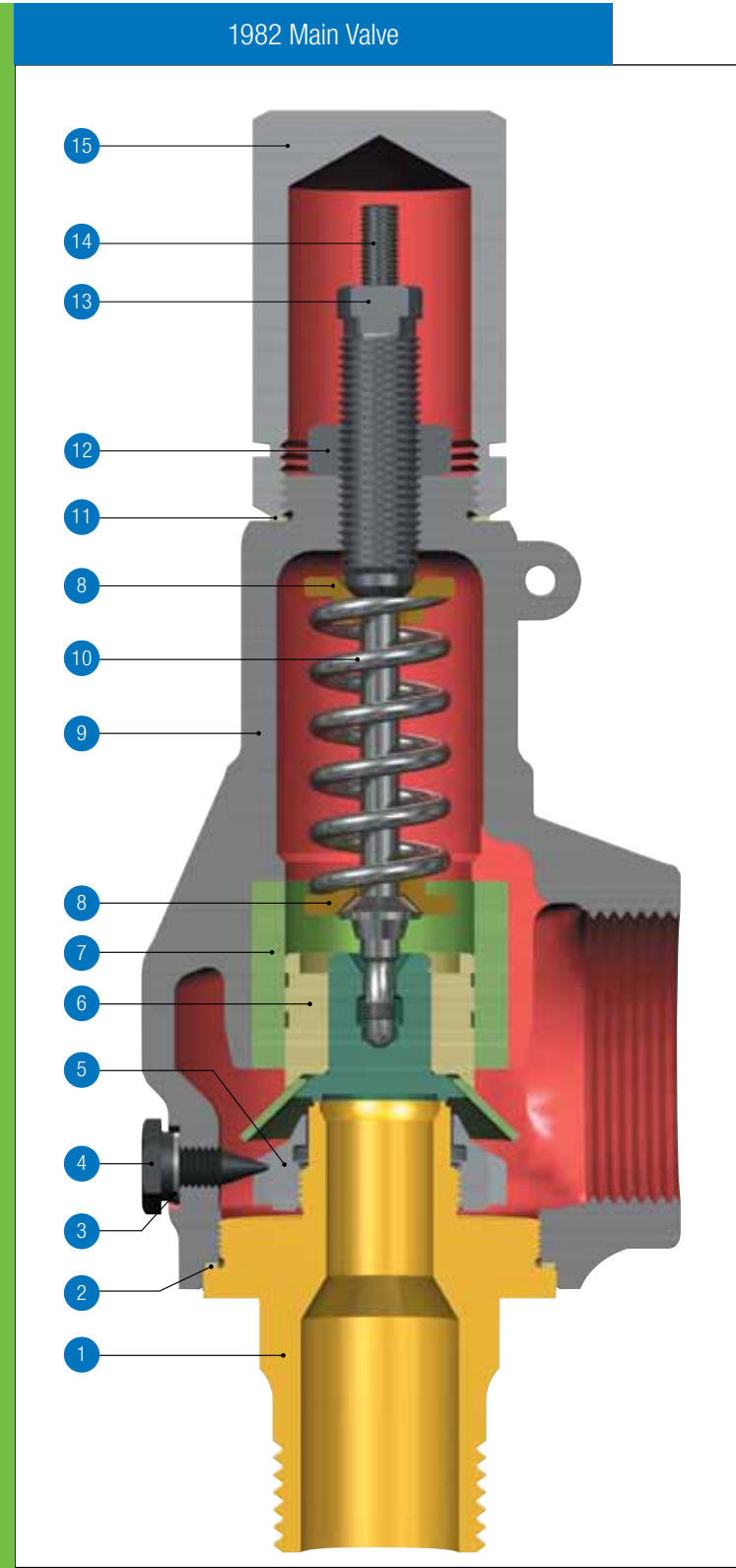

# Materials (Contd.)

## 1982 Standard Materials

1982 Standard Material (-CC)		
Ref. No.	Part	Construction Variation (-CC)
1	Base	ASME SA479 316 Stainless Steel
1A	Inlet Flange (When Applicable)	ASME SA105 Carbon Steel
2	Bonnet Gasket	Soft Iron
3	Adjusting Ring Pin Gasket	Soft Iron
4	Adjusting Ring Pin	416 Stainless Steel
5	Adjusting Ring	316 Stainless Steel
6	Disc Assembly	
6a	Disc Collar	316 Stainless Steel
6b	Disc Holder	316 Stainless Steel
6c	Disc	316 Stainless Steel
6d	Disc Retainer	PH15-7 Moly Stainless Steel
7	Guide	410 Stainless Steel
8	Spring Washer	Carbon Steel <sup>1</sup>
9	Bonnet	ASME SA216 WCC Carbon Steel <sup>1</sup>
10	Spring	
	1982c	Alloy Steel <sup>1</sup>
	1982t	Inconel X-750
11	Cap Gasket	Soft Iron
12	Adjusting Screw Locknut	Carbon Steel <sup>1</sup>
13	Adjusting Screw	416 Stainless Steel
14	Spindle Assembly	
14a	Spindle	Carbon Steel <sup>1</sup>
14b	Spindle Collar	410 Stainless Steel
15	Screwed Cap	Carbon Steel <sup>1</sup>
16	Plain Cap	Malleable Iron
17	Release Locknut	Carbon Steel
18	Release Nut	416 Stainless Steel
19	Lever Pin	Carbon Steel
20	Plain Lever	Malleable Iron
21	Cap Screw	Carbon Steel
22	Packed Cap	Carbon Steel <sup>1</sup>
23	Packed Lever	Malleable Iron
24	O-Ring	Viton 70
25	Bushing	416 Stainless Steel
26	Cam Shaft	410 Stainless Steel
27	Drive Stud	Carbon Steel
28	Lever Gasket	Soft Iron
29	Gag	Carbon Steel
30	Sealing Plug	Carbon Steel
31	Sealing Plug Gasket	Soft Iron

### Notes:

1. Black Oxide Coating.

# Materials (Contd.)

## 1982 Optional Materials

Stainless Material Variation	
Component	Construction Variation
	Stainless Steel (-CY)
Base	ASME SA479 304 Stainless Steel
Inlet Flange (When Applicable)	ASME SA182 304 Stainless Steel
Bonnet Gasket	A151 316 Stainless Steel (80R <sub>P</sub> )
Adjusting Ring Pin Gasket	A151 316 Stainless Steel (80R <sub>P</sub> )
Adjusting Ring Pin	316 Stainless Steel
Adjusting Ring	316 Stainless Steel
Disc Collar	304 Stainless Steel
Disc Holder	304 Stainless Steel
Disc	304 Stainless Steel
Disc Retainer	PH15-7 Moly Stainless Steel
Guide	316 Stainless Steel
Spring Washer	316 Stainless Steel
Bonnet	ASME SA351 CF8M Stainless Steel
Spring - 1982c	316 Stainless Steel
Spring - 1982t	N/A
Cap Gasket	A151 316 Stainless Steel (80R <sub>P</sub> )
Adjusting Screw Locknut	316 Stainless Steel
Adjusting Screw	316 Stainless Steel
Spindle	316 Stainless Steel
Spindle Collar	316 Stainless Steel
Screwed Cap	304 Stainless Steel
Plain Cap	N/A
Release Locknut	N/A
Release Nut	N/A
Lever Pin	N/A
Plain Lever	N/A
Cap Screw	N/A
Packed Cap	N/A
Packed Lever	N/A
O-Ring	N/A
Bushing	N/A
Cam Shaft	N/A
Drive Stud	N/A
Lever Gasket	N/A
Gag	316 Stainless Steel
Sealing Plug	316 Stainless Steel
Sealing Plug Gasket	A151 316 Stainless Steel (80R <sub>P</sub> )

### Notes:

1. The materials in red denote variation from standard material construction.

# Materials (Contd.)

## 1982 Optional Materials (Contd.)

Hastelloy Material Variation <sup>1</sup>				
Component	Construction Variation			
	(-H1)	(-H2)	(-H3)	(-H4)
Base	Hastelloy C	Hastelloy C	Hastelloy C	Hastelloy C
Inlet Flange (When Applicable)	ASME SA105 Carbon Steel	ASME SA105 Carbon Steel	ASME SB574 N10276	ASME SB574 N10276
Bonnet Gasket	Soft Iron	Soft Iron	Monel	Monel
Adjusting Ring Pin Gasket	Soft Iron	Soft Iron	Monel	Monel
Adjusting Ring Pin	416 Stainless Steel	Hastelloy C	Hastelloy C	Hastelloy C
Adjusting Ring	316 Stainless Steel	Hastelloy C	Hastelloy C	Hastelloy C
Disc Collar	Hastelloy C	Hastelloy C	Hastelloy C	Hastelloy C
Disc Holder	304 Stainless Steel	Hastelloy C	Hastelloy C	Hastelloy C
Disc	Hastelloy C	Hastelloy C	Hastelloy C	Hastelloy C
Disc Retainer	PH15-7 Moly Stainless Steel	PH15-7 Moly Stainless Steel	PH15-7 Moly SSt.	PH15-7 Moly SSt.
Guide	410 Stainless Steel	Hastelloy C	Hastelloy C	Hastelloy C
Spring Washer	Carbon Steel <sup>2</sup>	Carbon Steel <sup>2</sup>	Carbon Steel <sup>2</sup>	Hastelloy C
Bonnet	ASME SA216 WCC Carbon Steel <sup>2</sup>	ASME SA216 WCC Carbon Steel <sup>2</sup>	Hastelloy C	Hastelloy C
Spring - 1982c	Alloy Steel <sup>2</sup>	Alloy Steel <sup>2</sup>	Alloy Steel <sup>2</sup>	Hastelloy C
Spring - 1982t	Inconel X-750	Inconel X-750	Inconel X-750	Hastelloy C
Cap Gasket	Soft Iron	Soft Iron	Monel	Monel
Adjusting Screw Locknut	Carbon Steel <sup>2</sup>	Carbon Steel <sup>2</sup>	Hastelloy C	Hastelloy C
Adjusting Screw	416 Stainless Steel	416 Stainless Steel	Hastelloy C	Hastelloy C
Spindle	Carbon Steel <sup>2</sup>	Hastelloy C	Hastelloy C	Hastelloy C
Spindle Collar	410 Stainless Steel	Hastelloy C	Hastelloy C	Hastelloy C
Screwed Cap	Carbon Steel <sup>2</sup>	Carbon Steel <sup>2</sup>	Hastelloy C	Hastelloy C
Plain Cap	Malleable Iron	Malleable Iron	N/A	N/A
Release Locknut	Carbon Steel	Carbon Steel	N/A	N/A
Release Nut	416 Stainless Steel	416 Stainless Steel	N/A	N/A
Lever Pin	Carbon Steel	Carbon Steel	N/A	N/A
Plain Lever	Malleable Iron	Malleable Iron	N/A	N/A
Cap Screw	Carbon Steel	Carbon Steel	N/A	N/A
Packed Cap	Carbon Steel <sup>2</sup>	Carbon Steel <sup>2</sup>	N/A	N/A
Packed Lever	Malleable Iron	Malleable Iron	N/A	N/A
O-Ring	Viton 70	Viton 70	N/A	N/A
Bushing	416 Stainless Steel	416 Stainless Steel	N/A	N/A
Cam Shaft	410 Stainless Steel	410 Stainless Steel	N/A	N/A
Drive Stud	Carbon Steel	Carbon Steel	N/A	N/A
Lever Gasket	Soft Iron	Soft Iron	N/A	N/A
Gag	Carbon Steel	Carbon Steel	Hastelloy C	Hastelloy C
Sealing Plug	Carbon Steel	Carbon Steel	Hastelloy C	Hastelloy C
Sealing Plug Gasket	Soft Iron	Soft Iron	Monel	Monel

### Notes:

1. The materials in red denote variation from standard material construction.
2. Black Oxide Coating.

# Materials (Contd.)

## 1982 Optional Materials (Contd.)

Monel Material Variation <sup>1</sup>					
Component	Construction Variation				
	(-M1)	(-MB or M1-1/2)	(-M2)	(-M3)	(-M4)
Base	Monel	Monel	Monel	Monel	Monel
Inlet Flange (when applicable)	ASME SA105 CS	ASME SA105 CS	ASME SA105 CS	ASME SB564 N04400	ASME SB564 N04400
Bonnet Gasket	Soft Iron	Soft Iron	Soft Iron	Monel	Monel
Adjusting Ring Pin Gasket	Soft Iron	Soft Iron	Soft Iron	Monel	Monel
Adjusting Ring Pin	416 Stainless Steel	Monel	Monel	Monel	Monel
Adjusting Ring	316 Stainless Steel	Monel	Monel	Monel	Monel
Disc Collar	Monel	Monel	Monel	Monel	Monel
Disc Holder	304 Stainless Steel	Monel	Monel	Monel	Monel
Disc	Monel	Monel	Monel	Monel	Monel
Disc Retainer	PH15-7 Moly SST.	PH15-7 Moly SST.	PH15-7 Moly SST.	PH15-7 Moly SST.	PH15-7 Moly SST.
Guide	410 Stainless Steel	Monel	Monel	Monel	Monel
Spring Washer	Carbon Steel <sup>2</sup>	Carbon Steel <sup>2</sup>	Carbon Steel <sup>2</sup>	Carbon Steel <sup>2</sup>	Monel
Bonnet	ASME SA216 WCC CS <sup>2</sup>	ASME SA216 WCC CS <sup>2</sup>	ASME SA216 WCC CS <sup>2</sup>	Monel	Monel
Spring 1982c	Alloy Steel <sup>2</sup>	Alloy Steel <sup>2</sup>	Alloy Steel <sup>2</sup>	Alloy Steel <sup>2</sup>	Inconel X-750
Spring 1982t	Inconel X-750	Inconel X-750	Inconel X-750	Inconel X-750	Inconel X-750
Cap Gasket	Soft Iron	Soft Iron	Soft Iron	Monel	Monel
Adjusting Screw Locknut	Carbon Steel <sup>2</sup>	Carbon Steel <sup>2</sup>	Carbon Steel <sup>2</sup>	Monel	Monel
Adjusting Screw	416 Stainless Steel	416 Stainless Steel	416 Stainless Steel	Monel	Monel
Spindle	Carbon Steel <sup>2</sup>	Carbon Steel <sup>2</sup>	Monel	Monel	Monel
Spindle Collar	410 Stainless Steel	410 Stainless Steel	Monel	Monel	Monel
Screwed Cap	Carbon Steel <sup>2</sup>	Carbon Steel <sup>2</sup>	Carbon Steel <sup>2</sup>	Monel	Monel
Plain Cap	Malleable Iron	Malleable Iron	Malleable Iron	N/A	N/A
Release Locknut	Carbon Steel	Carbon Steel	Carbon Steel	N/A	N/A
Release Nut	416 Stainless Steel	416 Stainless Steel	416 Stainless Steel	N/A	N/A
Lever Pin	Carbon Steel	Carbon Steel	Carbon Steel	N/A	N/A
Plain Lever	Malleable Iron	Malleable Iron	Malleable Iron	N/A	N/A
Cap Screw	Carbon Steel	Carbon Steel	Carbon Steel	N/A	N/A
Packed Cap	Carbon Steel <sup>2</sup>	Carbon Steel <sup>2</sup>	Carbon Steel <sup>2</sup>	N/A	N/A
Packed Lever	Malleable Iron	Malleable Iron	Malleable Iron	N/A	N/A
O-Ring	Viton 70	Viton 70	Viton 70	N/A	N/A
Bushing	416 Stainless Steel	416 Stainless Steel	416 Stainless Steel	N/A	N/A
Cam Shaft	410 Stainless Steel	410 Stainless Steel	410 Stainless Steel	N/A	N/A
Drive Stud	Carbon Steel	Carbon Steel	Carbon Steel	N/A	N/A
Lever Gasket	Soft Iron	Soft Iron	Soft Iron	N/A	N/A
Gag	Carbon Steel	Carbon Steel	Carbon Steel	Monel	Monel
Sealing Plug	Carbon Steel	Carbon Steel	Carbon Steel	Monel	Monel
Sealing Plug Gasket	Soft Iron	Soft Iron	Soft Iron	Monel	Monel

### Notes:

1. The materials in red denote variation from standard material construction.
2. Black Oxide Coating.

# Materials (Contd.)

## 1982 Optional Materials (Contd.)

Stainless Steel Material Variation <sup>1</sup>			
Component	Construction Variation		
	(-S2)	(-S3)	(-S4)
Base	ASME SA479 316 Stainless Steel	ASME SA479 316 Stainless Steel	ASME SA479 316 Stainless Steel
Inlet Flange (When Applicable)	ASME SA105 Carbon Steel	ASME SA182 316 Stainless Steel	ASME SA182 316 Stainless Steel
Bonnet Gasket	Soft Iron	Monel	Monel
Adjusting Ring Pin Gasket	Soft Iron	Monel	Monel
Adjusting Ring Pin	316 Stainless Steel	316 Stainless Steel	316 Stainless Steel
Adjusting Ring	316 Stainless Steel	316 Stainless Steel	316 Stainless Steel
Disc Collar	316 Stainless Steel	316 Stainless Steel	316 Stainless Steel
Disc Holder	316 Stainless Steel	316 Stainless Steel	316 Stainless Steel
Disc	316 Stainless Steel	316 Stainless Steel	316 Stainless Steel
Disc Retainer	PH15-7 Moly Stainless Steel	PH15-7 Moly Stainless Steel	PH15-17 Moly Stainless Steel
Guide	316 Stainless Steel	316 Stainless Steel	316 Stainless Steel
Spring Washer	Carbon Steel <sup>2</sup>	Carbon Steel <sup>2</sup>	316 Stainless Steel
Bonnet	ASME SA216 WCC Carbon Steel <sup>2</sup>	ASME SA351 CF8M Stainless Steel	ASME SA351 CF8M Stainless Steel
Spring - 1982c	Alloy Steel <sup>2</sup>	Alloy Steel <sup>2</sup>	316 Stainless Steel
Spring - 1982t	Inconel X-750	Inconel X-750	316 Stainless Steel
Cap Gasket	Soft Iron	Monel	Monel
Adjusting Screw Locknut	Carbon Steel <sup>2</sup>	316 Stainless Steel	316 Stainless Steel
Adjusting Screw	416 Stainless Steel	316 Stainless Steel	316 Stainless Steel
Spindle	Carbon Steel <sup>2</sup>	316 Stainless Steel	316 Stainless Steel
Spindle Collar	410 Stainless Steel	316 Stainless Steel	316 Stainless Steel
Screwed Cap	Carbon Steel <sup>2</sup>	316 Stainless Steel	316 Stainless Steel
Plain Cap	Malleable Iron	316 Stainless Steel	316 Stainless Steel
Release Locknut	Carbon Steel	316 Stainless Steel	316 Stainless Steel
Release Nut	416 Stainless Steel	316 Stainless Steel	316 Stainless Steel
Lever Pin	Carbon Steel	316 Stainless Steel	316 Stainless Steel
Plain Lever	Malleable Iron	316 Stainless Steel	316 Stainless Steel
Cap Screw	Carbon Steel	316 Stainless Steel	316 Stainless Steel
Packed Cap	Carbon Steel <sup>2</sup>	316 Stainless Steel	316 Stainless Steel
Packed Lever	Malleable Iron	316 Stainless Steel	316 Stainless Steel
O-Ring	Viton 70	Viton 70	Viton 70
Bushing	416 Stainless Steel	316 Stainless Steel	316 Stainless Steel
Cam Shaft	410 Stainless Steel	316 Stainless Steel	316 Stainless Steel
Drive Stud	Carbon Steel	316 Stainless Steel	316 Stainless Steel
Lever Gasket	Soft Iron	Monel	Monel
Gag	Carbon Steel	316 Stainless Steel	316 Stainless Steel
Sealing Plug	Carbon Steel	316 Stainless Steel	316 Stainless Steel
Sealing Plug Gasket	Soft Iron	Monel	Monel

### Notes:

1. The materials in red denote variation from standard material construction.
2. Black Oxide Coating.

# Materials (Contd.)

## 1982 Optional Materials (Contd.)

Steam Service Material Variation <sup>1</sup>	
Component	Construction Variation
	Steam Service (-SS)
Base	ASME SA479 316 Stainless Steel
Inlet Flange (When Applicable)	ASME SA182 316 Stainless Steel
Bonnet Gasket	316 Stainless Steel
Adjusting Ring Pin Gasket	316 Stainless Steel
Adjusting Ring Pin	416 Stainless Steel
Adjusting Ring	316 Stainless Steel
Disc Collar	316 Stainless Steel
Disc Holder	316 Stainless Steel
Disc	316 Stainless Steel
Disc Retainer	PH15-17 Moly Stainless Steel
Guide	410 Stainless Steel
Spring Washer	316 Stainless Steel
Bonnet	ASME SA351 CF8M Stainless Steel
Spring - 1982c	316 Stainless Steel
Spring - 1982t	316 Stainless Steel
Cap Gasket	316 Stainless Steel
Adjusting Screw Locknut	316 Stainless Steel
Adjusting Screw	416 Stainless Steel
Spindle	316 Stainless Steel
Spindle Collar	316 Stainless Steel
Screwed Cap	316 Stainless Steel
Plain Cap	316 Stainless Steel
Release Locknut	316 Stainless Steel
Release Nut	316 Stainless Steel
Lever Pin	316 Stainless Steel
Plain Lever	316 Stainless Steel
Cap Screw	316 Stainless Steel
Packed Cap	316 Stainless Steel
Packed Lever	316 Stainless Steel
O-Ring	Viton 70
Bushing	316 Stainless Steel
Cam Shaft	316 Stainless Steel
Drive Stud	302 Stainless Steel
Lever Gasket	316 Stainless Steel
Gag	Carbon Steel
Sealing Plug	316 Stainless Steel
Sealing Plug Gasket	316 Stainless Steel

### Notes:

1. The materials in red denote variation from standard material construction.

# Dimensions & Weights

Main Valve Dimensions

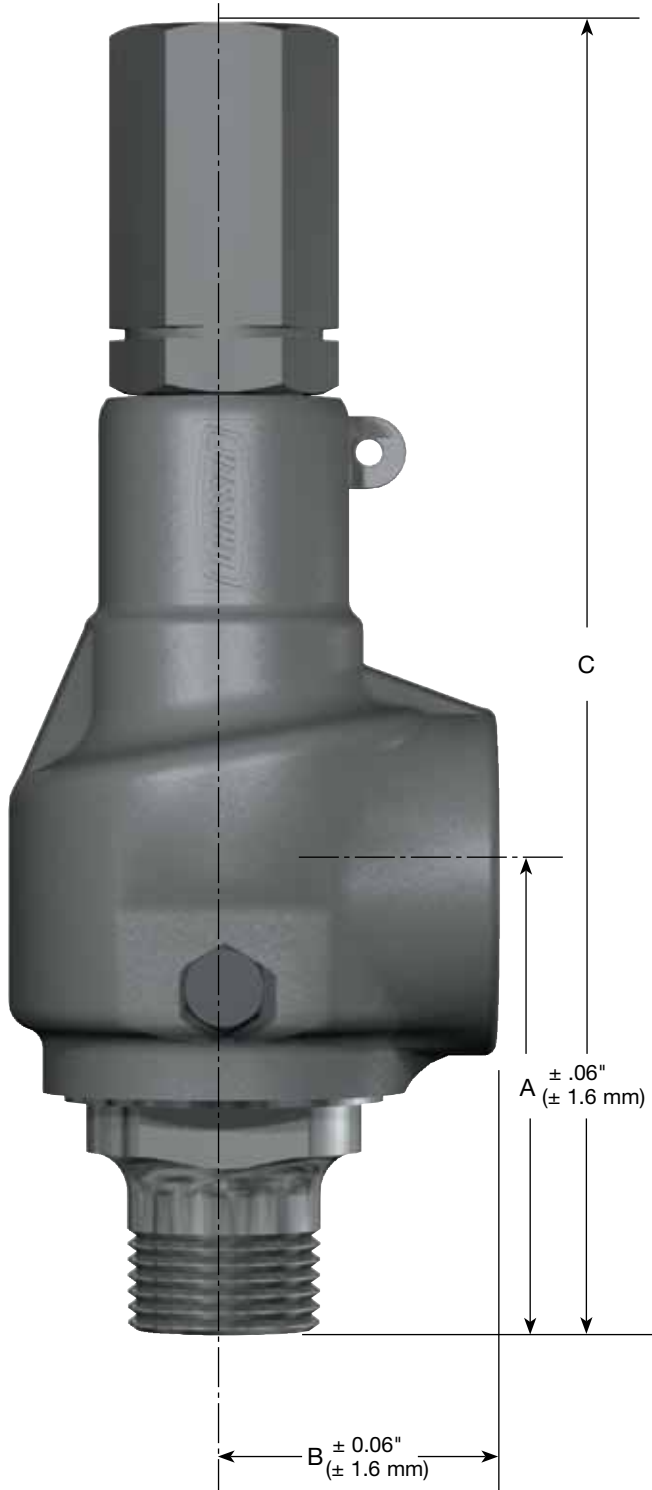

1982 Plain Lever

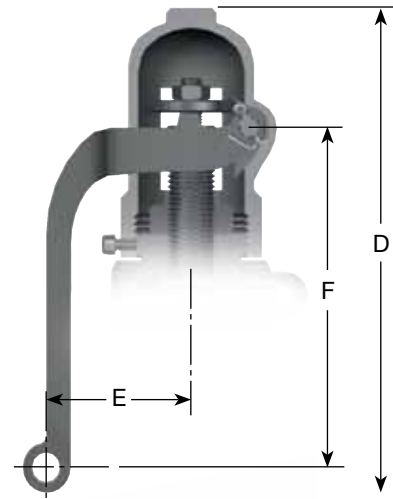

1982 Packed Lever

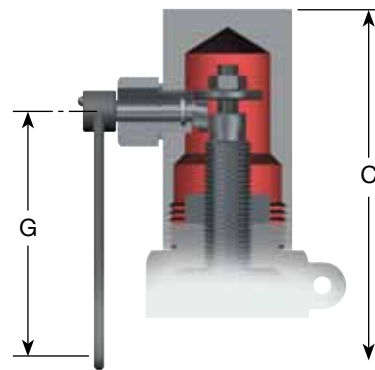

1982 Cap with Gag

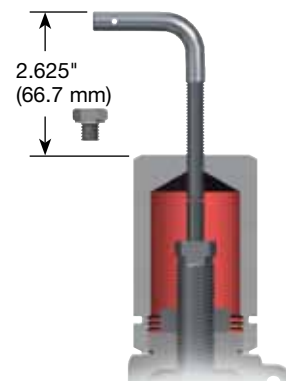

# Dimensions & Weights (Contd.)

General Valve Dimensions Threaded Inlet

Valve Type	Inlet Size		Inlet Type	Outlet Size		Outlet Type	A		B		C		D	
	in.	mm		in.	mm		in.	mm	in.	mm	in.	mm	in.	mm
1/2-1982	.50	12.70	MNPT	.75	19.05	FNPT	2.63	66.80	1.25	31.75	7.13	181.10	7.25	184.15
3/4-1982	.75	19.05	MNPT	1.00	25.40	FNPT	2.75	69.85	1.44	36.58	7.50	190.50	7.63	193.80
1-1982	1.00	25.40	MNPT	1.50	38.10	FNPT	3.25	82.55	1.88	47.75	9.13	231.90	9.13	231.90
1-1/2-1982	1.50	38.10	MNPT	2.00	50.80	FNPT	3.88	98.55	2.63	66.80	12.00	304.80	11.88	301.75
2-1982	2.00	50.80	MNPT	2.50	63.50	FNPT	4.38	111.25	3.25	82.55	14.06	357.12	13.88	352.55

General Valve Dimensions Threaded Inlet (Contd.)

Valve Type	Inlet Size		Inlet Type	Outlet Size		Outlet Type	E		F		G		Approx. Weight	
	in.	mm		in.	mm		in.	mm	in.	mm	in.	mm	lb	kg
1/2-1982	.50	12.70	MNPT	.75	19.05	FNPT	1.38	35.05	2.75	69.85	2.38	60.45	2.2	1.00
3/4-1982	.75	19.05	MNPT	1.00	25.40	FNPT	1.38	35.05	2.75	69.85	2.38	60.45	3.0	1.36
1-1982	1.00	25.40	MNPT	1.50	38.10	FNPT	2.13	54.10	4.63	117.60	3.50	88.90	5.0	2.27
1-1/2-1982	1.50	38.10	MNPT	2.00	50.80	FNPT	3.69	93.73	5.81	147.57	4.75	120.65	12.0	5.44
2-1982	2.00	50.80	MNPT	2.50	63.50	FNPT	3.69	93.73	5.81	147.57	4.75	120.65	18.5	8.39

# Dimensions & Weights (Contd.)

General Valve Dimensions Flanged Inlet														
Valve Type	Inlet Size		Inlet Type	Outlet Size		Outlet Type	A		B		C		D	
	in	mm		in	mm		in	mm	in	mm	in	mm	in	mm
1/2-1982	.50	12.70	150# RF	.75	19.05	FNPT	2.69	68.33	1.25	31.75	7.13	181.10	7.25	184.15
	.50	12.70	300# RF				2.69	68.33	1.25	31.75	7.13	181.10	7.25	184.15
3/4-1982	.75	19.05	150# RF	1.00	25.40	FNPT	2.81	71.37	1.44	36.58	7.50	190.50	7.63	193.80
	.75	19.05	300# RF				2.81	71.37	1.44	36.58	7.50	190.50	7.63	193.80
1-1982	1.00	25.40	150# RF	1.50	38.10	FNPT	3.25	82.55	1.88	47.75	9.13	231.90	9.13	231.90
	1.00	25.40	300# RF				3.25	82.55	1.88	47.75	9.13	231.90	9.13	231.90
1-1/2-1982	1.50	38.10	150# RF	2.00	50.80	FNPT	4.06	103.12	2.63	66.80	12.00	304.80	11.88	301.75
	1.50	38.10	300# RF				4.06	103.12	2.63	66.80	12.00	304.80	11.88	301.75
2-1982	2.00	50.80	150# RF	2.50	63.50	FNPT	4.63	117.60	3.25	82.55	14.06	357.12	13.88	352.55
	2.00	50.80	300# RF				4.63	117.60	3.25	82.55	14.06	357.12	13.88	352.55

General Valve Dimensions Flanged Inlet (Contd.)																
Valve Type	Inlet Size		Inlet Type	Outlet Size		Outlet Type	E		F		G		H		Approx. Weight	
	in	mm		in	mm		in	mm	in	mm	in	mm	lb	kg		
1/2-1982	.50	12.70	150# RF	.75	19.05	FNPT	1.38	35.05	2.75	69.85	2.38	60.45	.44	11.18	3.2	1.45
	.50	12.70	300# RF				1.38	35.05	2.75	69.85	2.38	60.45	.56	14.22	3.7	1.68
3/4-1982	.75	19.05	150# RF	1.00	25.40	FNPT	1.38	35.05	2.75	69.85	2.38	60.45	.50	12.70	4.5	2.04
	.75	19.05	300# RF				1.38	35.05	2.75	69.85	2.38	60.45	.63	16.00	5.5	2.49
1-1982	1.00	25.40	150# RF	1.50	38.10	FNPT	2.13	54.10	4.63	117.60	3.50	88.90	.56	14.22	7.0	3.18
	1.00	25.40	300# RF				2.13	54.10	4.63	117.60	3.50	88.90	.69	17.53	8.0	3.63
1-1/2-1982	1.50	38.10	150# RF	2.00	50.80	FNPT	3.69	93.73	5.81	147.57	4.75	120.65	.69	17.53	15.0	6.80
	1.50	38.10	300# RF				3.69	93.73	5.81	147.57	4.75	120.65	.81	20.57	18.5	8.39
2-1982	2.00	50.80	150# RF	2.50	63.50	FNPT	3.69	93.73	5.81	147.57	4.75	120.65	.75	19.05	23.5	10.66
	2.00	50.80	300# RF				3.69	93.73	5.81	147.57	4.75	120.65	.88	22.35	25.5	11.57

# Pressure/Temperature

## Pressure Temperature Ratings 1982 Series Valves Threaded Inlet

Valve Type	-20 °F (-28.9 °C)		100°F (37.8°C)		400°F (204.4°C)		800°F (426.7°C)	
	psig	barg	psig	barg	psig	barg	psig	barg
1/2-1982	500	34.47	500	34.47	500	34.47	500	34.47
3/4-1982	500	34.47	500	34.47	500	34.47	500	34.47
1-1982	500	34.47	500	34.47	500	34.47	500	34.47
1-1/2-1982	500	34.47	500	34.47	500	34.47	500	34.47
2-1982 <sup>1</sup>	500	34.47	500	34.47	500	34.47	500	34.47

### Notes:

1. Maximum set pressure for steam is 100 psig (6.89 barg) for the 2-1982.

## 150# Inlet Flange Rating

Temperature		Carbon Steel		316 Stainless		Monel		Hastelloy C	
°F	°C	psig	barg	psig	barg	psig	barg	psig	barg
-20 to 100	-28.9 to 37.8	285	19.65	275	18.96	230	15.86	290	19.99
200	93.3	260	17.93	235	16.20	200	13.79	260	17.93
300	148.9	230	15.86	215	14.82	190	13.10	230	15.86
400	204.4	200	13.79	195	13.44	180	12.41	200	13.79
500	260.0	170	11.72	170	11.72	170	11.72	170	11.72
600	315.6	140	9.65	140	9.65	140	9.65	140	9.65
650	343.3	125	8.62	125	8.62	125	8.62	125	8.62
700	371.1	110	7.58	110	7.58	110	7.58	110	7.58
750	398.9	95	6.55	95	6.55	95	6.55	95	6.55
800	426.7	80	5.52	80	5.52	80	5.52	80	5.52

## 300# Inlet Flange Rating

Temperature		Carbon Steel		316 Stainless		Monel		Hastelloy C	
°F	°C	psig	barg	psig	barg	psig	barg	psig	barg
-20 to 100	-28.9 to 37.8	740	51.02	720	49.64	600	41.37	750	51.71
200	93.3	680	46.88	620	42.75	525	36.20	750	51.71
300	148.9	655	45.16	560	38.61	490	33.78	730	50.33
400	204.4	635	43.78	515	35.51	475	32.75	700	48.26
500	260.0	605	41.71	480	33.09	475	32.75	665	45.85
600	315.6	570	39.30	450	31.03	475	32.75	605	41.71
650	343.3	550	37.92	440	30.34	475	32.75	590	40.68
700	371.1	530	36.54	435	29.99	470	32.41	570	39.30
750	398.9	505	34.82	425	29.30	465	32.06	530	36.54
800	426.7	410	28.27	420	28.96	460	31.72	510	35.16

# Capacities

## Valve Capacity for ASME B&PV Code Section VIII, for Air

Based at 10% overpressure or 3 psig (0.21 barg), whichever is greater, showing 90% of actual capacity.  
Units of ft<sup>3</sup>/min (m<sup>3</sup>/min) of air per minute are at a temperature of 60°F (15.6°C)

Inlet Size		in.	mm	in.	mm	in.	mm	in.	mm	in.	mm
		.50	12.7	.75	19.1	1.00	25.4	1.50	38.1	2.00	50.8
Orifice Area		in <sup>2</sup>	cm <sup>2</sup>	in <sup>2</sup>	cm <sup>2</sup>	in <sup>2</sup>	cm <sup>2</sup>	in <sup>2</sup>	cm <sup>2</sup>	in <sup>2</sup>	cm <sup>2</sup>
		0.121	0.781	0.216	1.394	0.332	2.142	0.857	5.529	1.399	9.026
Set Pressure		Orifice Capacity									
psig	barg	ft <sup>3</sup> /min	m <sup>3</sup> /min	ft <sup>3</sup> /min	m <sup>3</sup> /min	ft <sup>3</sup> /min	m <sup>3</sup> /min	ft <sup>3</sup> /min	m <sup>3</sup> /min	ft <sup>3</sup> /min	m <sup>3</sup> /min
15	1.03	62	2	110	3	170	5	439	12	717	20
20	1.38	71	2	127	4	196	6	507	14	827	23
30	2.07	90	3	161	5	248	7	641	18	1047	30
40	2.76	111	3	198	6	305	9	789	22	1288	36
50	3.45	132	4	236	7	363	10	937	27	1530	43
60	4.14	153	4	273	8	420	12	1085	31	1771	50
70	4.83	174	5	310	9	477	14	1233	35	2013	57
80	5.52	195	6	348	10	535	15	1381	39	2254	64
90	6.21	215	6	385	11	592	17	1529	43	2496	71
100	6.89	236	7	422	12	649	18	1677	47	2737	78
120	8.27	278	8	497	14	764	22	1972	56	3220	91
140	9.65	320	9	571	16	878	25	2268	64	3703	105
160	11.03	362	10	646	18	993	28	2564	73	4186	119
180	12.41	403	11	720	20	1108	31	2860	81	4669	132
200	13.79	445	13	795	23	1222	35	3156	89	5152	146
220	15.17	487	14	870	25	1337	38	3452	98	5635	160
240	16.55	529	15	944	27	1452	41	3748	106	6118	173
260	17.93	570	16	1019	29	1566	44	4044	115	6601	187
280	19.31	612	17	1093	31	1681	48	4340	123	7084	201
300	20.68	654	19	1168	33	1795	51	4635	131	7567	214
320	22.06	696	20	1243	35	1910	54	4931	140	8050	228
340	23.44	738	21	1317	37	2025	57	5227	148	8533	242
360	24.82	779	22	1392	39	2139	61	5523	156	9016	255
380	26.20	821	23	1466	42	2254	64	5819	165	9499	269
400	27.58	863	24	1541	44	2369	67	6115	173	9982	283
420	28.96	905	26	1615	46	2483	70	6411	182	10465	296
440	30.34	946	27	1690	48	2598	74	6707	190	10948	310
460	31.72	988	28	1765	50	2712	77	7002	198	11431	324
480	33.09	1030	29	1839	52	2827	80	7298	207	11914	337
500	34.47	1072	30	1914	54	2942	83	7594	215	12397	351

# Capacities (Contd.)

## Valve Capacity for ASME B&PV Code Section VIII, for Saturated Steam

Based at 10% overpressure or 3 psig (0.21 barg), whichever is greater, showing 90% of actual capacity.

Units of ft<sup>3</sup>/min (m<sup>3</sup>/min) of air per minute are at a temperature of 60°F (15.6°C)

Inlet Size		in.	mm	in.	mm	in.	mm	in.	mm	in.	mm
Orifice Area		in <sup>2</sup>	cm <sup>2</sup>	in <sup>2</sup>	cm <sup>2</sup>	in <sup>2</sup>	cm <sup>2</sup>	in <sup>2</sup>	cm <sup>2</sup>	in <sup>2</sup>	cm <sup>2</sup>
Set Pressure		Orifice Capacity									
psig	barg	lb/hr	kg/hr	lb/hr	kg/hr	lb/hr	kg/hr	lb/hr	kg/hr	lb/hr	kg/hr
15	1.03	174	79	311	141	478	217	1233	559	2014	914
20	1.38	200	91	358	162	551	250	1422	645	2322	1053
30	2.07	254	115	453	205	697	316	1800	816	2938	1333
40	2.76	312	142	558	253	858	389	2215	1005	3616	1640
50	3.45	371	168	662	300	1018	462	2630	1193	4293	1947
60	4.14	429	195	767	348	1179	535	3045	1381	4971	2255
70	4.83	488	221	872	396	1340	608	3460	1569	5648	2562
80	5.52	547	248	976	443	1501	681	3875	1758	6326	2869
90	6.21	605	274	1081	490	1662	754	4290	1946	7004	3177
100	6.89	664	301	1186	538	1822	826	4705	2134	7681	3484
120	8.27	781	354	1395	633	2144	973	5535	2511	N/A	N/A
140	9.65	898	407	1604	728	2466	1119	6366	2888	N/A	N/A
160	11.03	1016	461	1813	822	2787	1264	7196	3264	N/A	N/A
180	12.41	1133	514	2022	917	3109	1410	8026	3641	N/A	N/A
200	13.79	1250	567	2232	1012	3431	1556	8856	4017	N/A	N/A
220	15.17	1367	620	2441	1107	3752	1702	9686	4393	N/A	N/A
240	16.55	1484	673	2650	1202	4074	1848	10516	4770	N/A	N/A
260	17.93	1602	727	2859	1297	4395	1994	11347	5147	N/A	N/A
280	19.31	1719	780	3069	1392	4717	2140	12177	5523	N/A	N/A
300	20.68	1836	833	3278	1487	5039	2286	13007	5900	N/A	N/A
320	22.06	1953	886	3487	1582	5360	2431	13837	6276	N/A	N/A
340	23.44	2070	939	3696	1676	5682	2577	14667	6653	N/A	N/A
360	24.82	2188	992	3906	1772	6003	2723	15498	7030	N/A	N/A
380	26.20	2305	1046	4115	1867	6325	2869	16328	7406	N/A	N/A
400	27.58	2422	1099	4324	1961	6647	3015	17158	7783	N/A	N/A
420	28.96	2539	1152	4533	2056	6968	3161	17988	8159	N/A	N/A
440	30.34	2657	1205	4743	2151	7290	3307	18818	8536	N/A	N/A
460	31.72	2774	1258	4952	2246	7612	3453	19649	8913	N/A	N/A
480	33.09	2891	1311	5161	2341	7933	3598	20479	9289	N/A	N/A
500	34.47	3008	1364	5370	2436	8255	3744	21309	9666	N/A	N/A

# Capacities (Contd.)

## Valve Capacity for ASME B&PV Code Section VIII, for Water

Based at 10% overpressure or 3 psig (0.21 barg), whichever is greater, showing 90% of actual capacity.  
Units of ft<sup>3</sup>/min (m<sup>3</sup>/min) of air per minute are at a temperature of 60°F (15.6°C)

Inlet Size		in.	mm	in.	mm	in.	mm	in.	mm	in.	mm
		.50	12.7	.75	19.1	1.00	25.4	1.50	38.1	2.00	50.8
Orifice Area		in <sup>2</sup>	cm <sup>2</sup>	in <sup>2</sup>	cm <sup>2</sup>	in <sup>2</sup>	cm <sup>2</sup>	in <sup>2</sup>	cm <sup>2</sup>	in <sup>2</sup>	cm <sup>2</sup>
		0.121	0.781	0.216	1.394	0.332	2.142	0.857	5.529	1.399	9.026
Set Pressure		Orifice Capacity									
psig	barg	gal/min	L/min	gal/min	L/min	gal/min	L/min	gal/min	L/min	gal/min	L/min
15	1.03	14.78	56	26.39	100	40.57	154	104.72	396	170.95	647
20	1.38	16.71	63	29.83	113	45.86	174	118.38	448	193.25	732
30	2.07	20.02	76	35.73	135	54.93	208	141.80	537	231.48	876
40	2.76	23.11	87	41.26	156	63.43	240	163.73	620	267.29	1012
50	3.45	25.84	98	46.13	175	70.91	268	183.06	693	298.83	1131
60	4.14	28.31	107	50.54	191	77.68	294	200.53	759	327.36	1239
70	4.83	30.58	116	54.59	207	83.91	318	216.60	820	353.59	1338
80	5.52	32.69	124	58.36	221	89.70	340	231.55	877	378.00	1431
90	6.21	34.67	131	61.90	234	95.14	360	245.60	930	400.93	1518
100	6.89	36.55	138	65.25	247	100.29	380	258.89	980	422.62	1600
120	8.27	40.04	152	71.47	271	109.86	416	283.60	1074	462.96	1752
140	9.65	43.24	164	77.20	292	118.66	449	306.32	1160	500.05	1893
160	11.03	46.23	175	82.53	312	126.86	480	327.47	1240	534.58	2024
180	12.41	49.04	186	87.54	331	134.55	509	347.33	1315	567.00	2146
200	13.79	51.69	196	92.27	349	141.83	537	366.12	1386	597.67	2262
220	15.17	54.21	205	96.78	366	148.75	563	383.99	1454	626.85	2373
240	16.55	56.62	214	101.08	383	155.37	588	401.07	1518	654.72	2478
260	17.93	58.93	223	105.21	398	161.71	612	417.44	1580	681.45	2580
280	19.31	61.16	232	109.18	413	167.82	635	433.20	1640	707.18	2677
300	20.68	63.31	240	113.01	428	173.71	658	448.41	1697	732.00	2771
320	22.06	65.38	247	116.72	442	179.41	679	463.11	1753	756.01	2862
340	23.44	67.40	255	120.31	455	184.93	700	477.37	1807	779.27	2950
360	24.82	69.35	263	123.80	469	190.29	720	491.21	1859	801.87	3035
380	26.20	71.25	270	127.19	481	195.50	740	504.67	1910	823.84	3119
400	27.58	73.10	277	130.50	494	200.58	759	517.78	1960	845.24	3200
420	28.96	74.91	284	133.72	506	205.54	778	530.56	2008	866.12	3279
440	30.34	76.67	290	136.87	518	210.37	796	543.05	2056	886.50	3356
460	31.72	78.39	297	139.94	530	215.10	814	555.25	2102	906.42	3431
480	33.09	80.08	303	142.95	541	219.73	832	567.20	2147	925.92	3505
500	34.47	81.73	309	145.90	552	224.26	849	578.89	2191	945.01	3577

# Valve Configuration Code

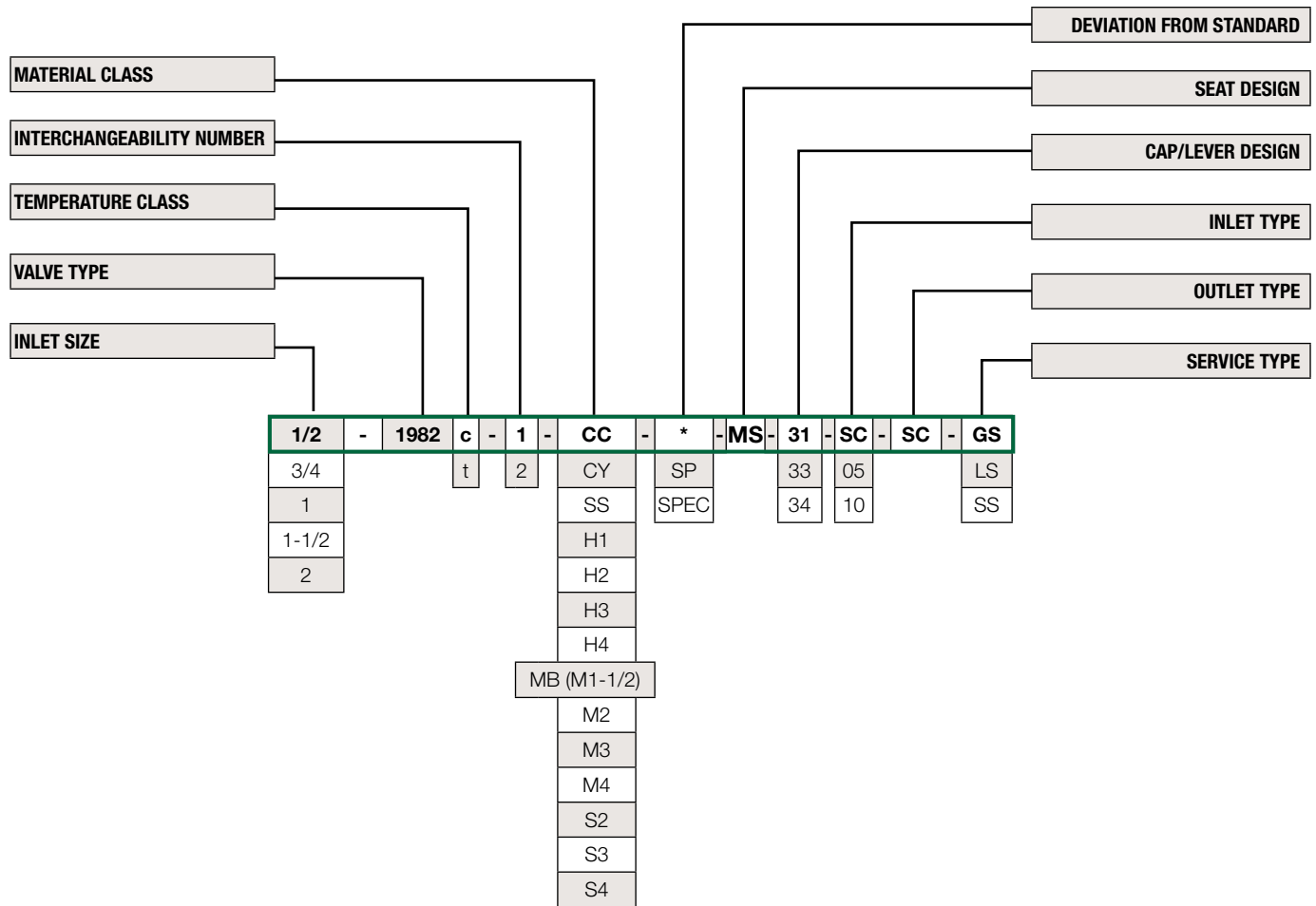

# Valve Configuration Code (Contd.)

## Standard Connections

Size		Orifice Area	
in.	mm	in <sup>2</sup>	cm <sup>2</sup>
.50	12.70	0.121	0.781
.75	19.05	0.216	1.394
1.00	25.40	0.332	2.142
1.50	38.10	0.857	5.529
2.00	50.80	1.399	9.026

## Temperature Class

Designation	Range
c	400°F (204.4°C) AND BELOW
t	401°F (204.4°C) AND ABOVE

## Material Class Variations

Designation	Description
CC	Standard Material
CY	Stainless Steel
SS	Stainless Steel
H1	Hastelloy C (Base & Disc)
H2	Hastelloy C (Internals, Except Spring Assembly)
H3	Hastelloy C (All Except Spring Assembly)
H4	Hastelloy C (Complete Valve)
M1	Monel (Base, Disc, Adjusting Ring & Pin)
MB (M1-1/2)	Monel (M1+Disc Holder & Guide)
M2	Monel (Internals, Except Spring Assembly)
M3	Monel (All Except Spring Assembly)
M4	Monel (Complete Valve)
S2	Stainless Steel (Internals, Except Spring Assembly)
S3	Stainless Steel (All Except Spring Assembly)
S4	Stainless Steel (Complete Valve)

## Interchangeability Number

Designation	Valve Type	
	Current Inlet	
	in.	mm
1	.50 to 1.50	12.70 to 38.10
2	2	50.80

## Seat Type

Designation	Description
MS	Metal Seat

## Cap/Lever Design

Designation	Description
31	Screwed
33	Packed
34	Plain

## Inlet Type

Designation	Description
SC	Screwed
05	150# Raised Face
10	300# Raised Face

## Outlet Type

Designation	Description
SC	Screwed

## Service

Designation	Description
GS	Gas
LS	Liquid
SS	Steam

# How to Order a 1982 SRV

Specification Sheet			
		Page ____ of ____	
Requisition No.	_____		
Job No.	_____		
Date	_____		
Revised By	_____		
General			
1.	Item Number:		
2.	Tag Number:		
3.	Service, Line or Equipment No:		
4.	Number Required:		
Basis of Selection			
5.	Code:		
	<input type="checkbox"/> ASME Sec. III		
	<input type="checkbox"/> ASME Sec. VIII		
	<input type="checkbox"/> OTHER Specify:		
6.	<input type="checkbox"/> Fire <input type="checkbox"/> OTHER Specify:		
7.	Rupture Disk: <input type="checkbox"/> YES <input type="checkbox"/> NO		
Valve Design			
8.	Type: Safety Relief		
9.	Design:		
	<input type="checkbox"/> Metal Seat <input type="checkbox"/> Resilient Seat		
	<input type="checkbox"/> API 527 Seat Tightness		
	<input type="checkbox"/> OTHER Specify:		
Connections			
10.	Flanged		
	Inlet Size:	Rating:	Facing:
	Outlet Size:	Rating:	Facing:
11.	Threaded		
	Inlet:	<input type="checkbox"/> MNPT	<input type="checkbox"/> FNPT
	Outlet:	<input type="checkbox"/> MNPT	<input type="checkbox"/> FNPT
12.	<input type="checkbox"/> OTHER Specify:		
Materials			
13.	Base:		
14.	Bonnet:		
15.	Guide/Rings:		
16.	Seat Material:		
	Metal:		
	Resilient:		
17.	Spring:		
18.	Comply with NACE MRO 175 <input type="checkbox"/> YES <input type="checkbox"/> NO		
19.	<input type="checkbox"/> OTHER Specify:		
20.	Cap and Lever Selection		
	<input type="checkbox"/> Screwed Cap (Standard) <input type="checkbox"/> Bolted Cap		
	<input type="checkbox"/> Plain Lever <input type="checkbox"/> Packed Lever <input type="checkbox"/> Gag		
21.	<input type="checkbox"/> OTHER Specify:		
Service Conditions			
22.	Fluid and State:		
23.	Required Capacity per Valve & Units:		
24.	Molecular Weight or Specific Gravity:		
25.	Viscosity at Flowing Temperature & Units:		
26.	Operating Pressure & Units:		
27.	Blowdown: <input type="checkbox"/> Standard <input type="checkbox"/> Other		
28.	Latent Heat of Vaporization & Units:		
29.	Operating Temperature & Units:		
30.	Relieving Temperature & Units:		
31.	Built-up Back Pressure & Units:		
32.	Superimposed Back Pressure & Units:		
33.	Cold differential Test Pressure & Units:		
34.	Allowable Overpressure in Percent or Units:		
35.	Compressibility Factor, Z:		
36.	Ratio of Specific Heats:		
Sizing and Selection			
37.	Calculated Orifice Area: _____ in <sup>2</sup> _____ cm <sup>2</sup>		
38.	Selected Orifice Area: _____ in <sup>2</sup> _____ cm <sup>2</sup>		
39.	Orifice Designation (letter):		
40.	Manufacturer:		
41.	Model Number:		
42.	Vendor Calculations Required: <input type="checkbox"/> YES <input type="checkbox"/> NO		



