



13900 Series

Consolidated® Pilot Operated Safety Relief Valve



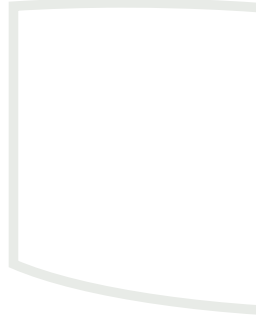

Table of Contents

Conversion Table	13900.2
Features & Benefits	13900.3
Applications	13900.4
Scope of Design	13900.5
Materials	13900.6
13900 Type Main Valve	13900.6
13900 Standard Materials	13900.7
13900 Type Pilot Valve	13900.8
Options	13900.9
Standard Options	13900.9
Dimensions & Weights	13900.10
Capacities	13900.11
Valve Configuration Code	13900.12
How to Order a 13900 POSRV	13900.13



Conversion Table

All the USCS values are converted to Metric values using the following conversion factors:

USCS Unit	Conversion Factor	Metric Unit
in.	25.4	mm
lb.	0.4535924	kg
in ²	6.4516	cm ²
ft ³ /min	0.02831685	m ³ /min
gal/min	3.785412	L/min
lb/hr	0.4535924	kg/hr
psig	0.06894757	barg
ft lb	1.3558181	Nm
°F	5/9 (°F-32)	°C

The Consolidated® 13900 Series pilot operated safety relief valve is designed specifically for high capacity steam applications and contributes to the overall efficiency and profitability of plant operations.



INLET SIZES	16" (103 mm) through 20" (129 mm)
OUTLET SIZES	18" (116 mm) through 24" (154 mm)
INLET RATINGS	ANSI Class 300
OUTLET RATINGS	ANSI Class 150
ORIFICE SIZES	Four sizes: 114, 143, 176 and 200.
PRESSURE RANGE	50 psig (3.45 barg) to 300 psig (20.68 barg)
TEMPERATURE RANGE	250°F (121°C) to 550°F (288°C)
MATERIALS	
MAIN VALVE	Carbon steel base and 316 stainless steel internal components.
PILOT VALVE (Std.)	304 stainless steel base and internal components.

CERTIFICATIONS

- ASME B & PVC, Section VIII, Division I
- ASME B & PV, Code Section II
- ASME B16.34
- ASME B16.5
- ASME B16.9
- MSS SP-44



Features & Benefits

For system applications that require the releasing of large discharge capacities, the Consolidated® 13900 valve series provides maximum reliable working economy and a simple efficient valve design. It also features a valve configuration that facilitates valve installation and in-line valve maintenance.

- **Greater Total System Efficiency**

The main valve can handle extremely large relieving capacities, in excess of 3,000,000 lbs of steam per hour (1,360,777 kg/hr). It has a seven to one discharge capacity over "T" type orifice, and a two to one discharge capacity over "W" type orifice.

- **Improved Design**

The total valve external configuration is considerably smaller in size, and the valve is lighter in weight than a comparable spring loaded valve. Because of these features, less space is required for valve installation.

A simple, efficient, and reliable direct acting valve design with few components, eliminates the need for excessive spare parts inventory and reduces maintenance time.

- **Easy Installation and Maintenance**

Valve configuration is considerably smaller in size and lighter in weight than a comparable spring loaded valve. This facilitates ease of installation, field handling, testing, and valve maintenance.

Valve maintenance is relatively simple and straightforward. The simple valve design means fewer parts. Fewer valve parts mean that less can go wrong, malfunctions can be readily diagnosed, and maintenance cost and process downtime can be kept to a minimum.

To facilitate valve maintenance, all main valve components are removable through the top bonnet of the valve. The pilot valve can be field tested and repaired without breaking inlet and outlet piping connections on the main valve. The pilot valve opening and closing is easily adjusted on a small test facility.

Features & Benefits (Contd.)

- **Description**

The 13900 pilot operated safety valve is an ASME Section VIII approved valve intended for use on compressible fluids. The valve design is simple. It consists of a small conventional, fail-safe pilot safety valve and main valve.

Overcompression of the main valve seat O-Ring, located between the disc and bushing, is eliminated by the metal-to-metal contact bearing surfaces between the disc and bushing. O-Ring seal blowout is eliminated by removing the pressure from behind the O-Ring via two small slots when the valve is open and flowing. A condensate drain hole in the disc facilitates drainage of any accumulated moisture in the upper disc cavity.

The spring loaded U-shaped Teflon® guide seal provides increased seat tightness as system pressure increases. The teflon material minimizes friction on the main disc and allows for reliable, dependable, and repeatable disc action. The seal spring load insures sealing at all times.

Teflon® guide rings eliminate metal-to-metal contact between the disc and guide, and eliminates friction. Main valve disc action is repeatable and reliable.

The pilot valve action directly controls the pressure forces on the main valve disc and eliminates the need for a transfer valve. System pressure which actuates the pilot valve is transmitted through a simple, full flow design sensing tube. The sensing tube eliminates small orifice control parts and their possible clogging characteristics and is enclosed within the valve body which protects it from damage and freezing.

Pilot valve blowdown adjustment can be set independently of the main valve. Adjustment and setting can be made prior to installing on the main valve.

The pilot valve disc is a metal seated design that is easily serviced and provides a seat tightness to 95% of set pressure.

The main unloading valve has a large orifice up to 200 in² (1290 cm²), which reduces the number of valves required for overpressure protection. Installation costs for additional header nozzles and exhaust lines are eliminated.

The O-Ring seat seal design and the spring loaded Teflon® rings assure tightness, valve integrity, and facilitate valve maintenance.

Applications

- The 13900 pilot operated safety relief valve is designed for steam applications where pressures range from 50 psig (3.45 barg) to 300 psig (20.68 barg) and temperature ranges from 250°F (121°C) to 550°F (288°C). The temperature limit is applied to the valve to insure that the Teflon® seal rings will maintain sealing integrity.
- The 13900 valve can be used on any compressible fluid within the pressure and temperature limits of the valve provided the fluid media exhibits characteristics similar to saturated steam. For applications other than steam, the open lift lever cap should be reviewed for adequacy. If another cap design is required, it should be so stated.
- The 13900 series of valves are available in four sizes, 114, 143, 176 and 200 in² (735, 923, 1135 and 1290 cm²).

For all sizes except the 200 in² (1290 cm²) the largest possible relieving capacity is supplied for the valve inlet size specified.

- For those applications where discharge pressures at the valve outlet exceeds 10% of the pilot valve set pressure, or where economics dictate that higher discharge pressures be required, the pilot valve can be exhausted separately and the discharge pressure of the main valve can be allowed to increase above the limit of 10% of the pilot valve set pressure.
- Typical valve applications include, boiler feed pump turbines, flash tanks, steam lines and deaerator.



Scope of Design

3900 Flanged Series Overview

Standard Valve Connections

Valve Type	Orifice Area		Inlet			Outlet		
	In ²	cm ²	Size		Pressure Class	Size		Pressure Class
			In.	mm		In.	mm	
13906-114	114.000	735.480	16.00	406.4	300# R. F.	18.00	457.2	150# R. F. ¹
13906-143	143.100	923.220	18.00	457.2	300# R. F.	22.00	558.8	150# R. F. ²
13906-176	176.700	1140.000	20.00	508.0	300# R. F.	24.00	609.6	150# R. F.
13906-200	201.000	1296.770	20.00	508.0	300# R. F.	24.00	609.6	150# R. F.

Notes:

1. The 22" (558.8 mm) 150# flange is not covered by ANSI B16.5. Drilling is (20) 1.375" (34.93 mm) diameter holes on a 27.25" (692.2 mm) diameter bolt circle. Covered by MSS-SP-44.
2. Two holes on outlet drilling are tapped and threaded 1.125-7UNC-2B Thread, 1.5" (38.1 mm) deep.

Pressure/Temperature Limits

Valve Type	Set Pressure				Temperature			
	min.		max.		min.		max.	
	psig	barg	psig	barg	°F	°C	°F	°C
All Sizes	50	3.44	300	20.68	250	121.1	550	287.7

Materials

13900 Type Main Valve

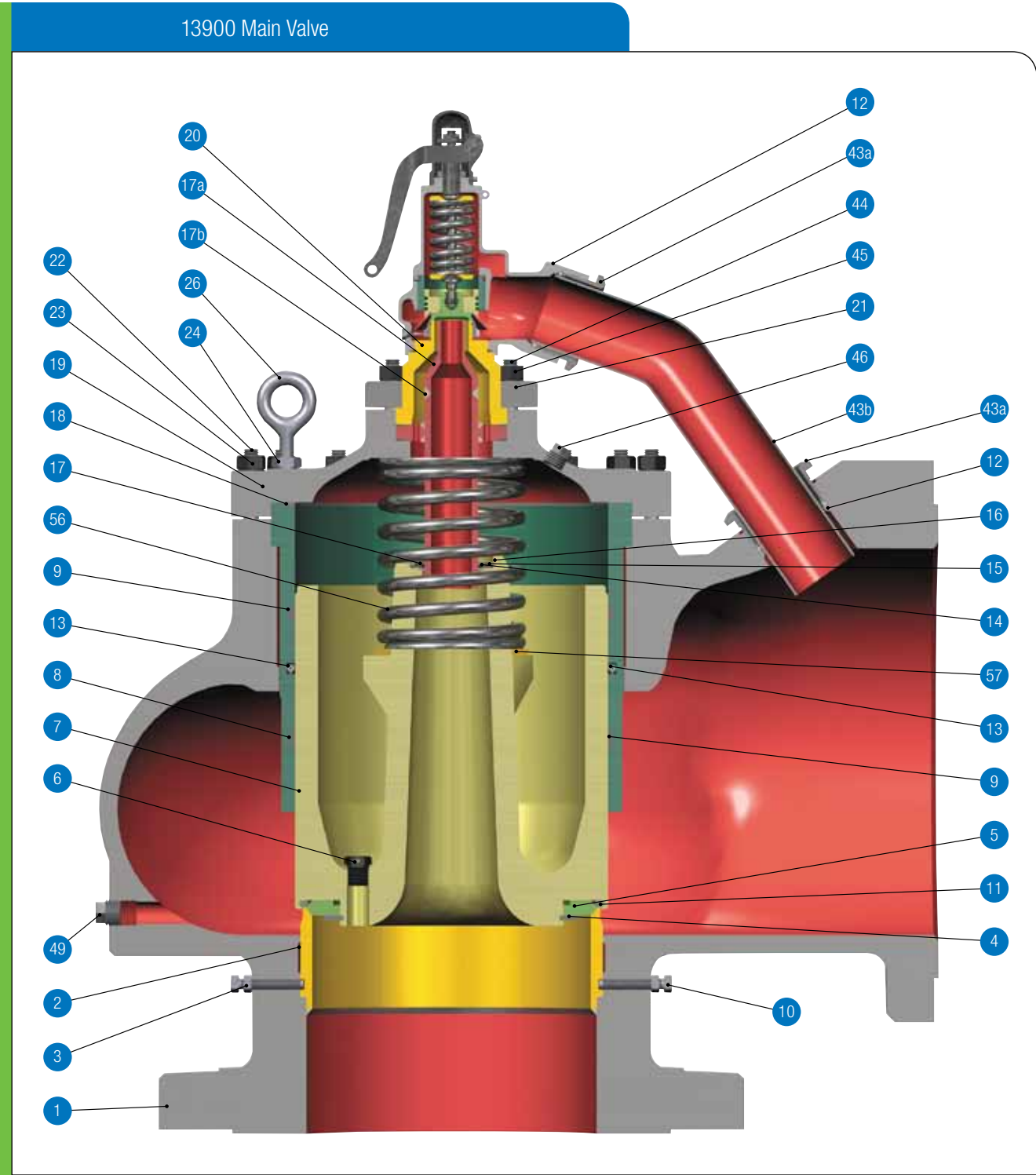

Materials (Contd.)

13900 Standard Materials

Standard Material for 13900 POSRV					
Ref. No.	Nomenclature	Material (-CC)	Ref. No.	Nomenclature	Material (-CC)
1	Main Base	ASME SA216 WCC CS	31	Spindle Assembly	
2	Seat Bushing	ASTM A451 CPF8M SSt.	31a	Spindle	ASTM A108 1213 CS
3	Seat Bushing Ret. Scr. Jam Nut	Carbon Steel (Cadmium Plated)	31b	Spindle Collar	ASTM A276 410 ³
4	Retainer Lock Ring	Carbon Steel (Nickel Plated)	32	Top Spring Washer	ASTM A108 1213 CS
5	O-Ring Retainer	ASTM A276 410 ¹	33	Lever	Malleable Iron
6	Disc Drain Plug	316 Stainless Steel	34	Compression Screw Lock Nut	ASTM A108 1213 CS
7	Main Disc	ASTM A743 CA6NM SSt.	35	Release Nut	ASTM A276 410 ³
8	Main Guide	ASTM A743 CA15 SSt.	36	Release Lock Nut	Carbon Steel
9	Back-up Ring	Teflon (Glass Filled)	37	Cap	ASTM A47 35018 ⁵
10	Seat Bushing Retainer Screw	ASTM A582 416 ¹	38	Lever Pin	Steel (Zinc Plated)
11	O-Ring Seat Seal	Teflon	39	Cap Lock Screw	Carbon Steel
12	Discharge Tube Fitting Seal	Teflon	40	Compression Screw	ASTM A582 416 ³
13	Guide Seal	Virgin Teflon Cover ²	41	Spring	
14	Floating Washer	ASTM A276 410 ³		250 - 400°F (121.1 - 204.4 °C)	Chrome Alloy
15	Floating Washer Retainer	ASTM A276 410 ³		401 - 550°F (205.0 - 287.8 °C)	Inconel
16	Fl. Washer Retainer Lock Ring	PH15-7 MO Stainless Steel	42	Pilot Disc Assembly	
17	Sensing Tube Assembly		42a	Disc	ASTM A276 410 ³
17a	Upper Tube	ASTM A479 304 SSt.	42b	Disc Holder	ASTM A479 304 SSt.
17b	Lower Tube	ASTM A269 TP304 SSt.	42c	Disc Collar	ASTM A167 304 SSt.
17c	Tube Flange	ASTM A108 1020 CS	42d	Retainer Ring	PH15-7 MO Stainless Steel
18	Bonnet Gasket	ASTM A167 304 SSt. ⁴	43	Discharge Tube Assembly	
19	Bonnet	ASME SA216 WCC CS	43a	Fitting	ASME SA105 Carbon Steel
20	Pilot Base	ASTM A479 304 SSt.	43b	Discharge Tube	ASTM A106 Grade B CS
21	Pilot Base Flange	ASME SA105 Carbon Steel	44	Bonnet Studs	ASTM A193 B7 Alloy Steel
22	Base Studs	ASTM A193 B7 Alloy Steel	45	Bonnet Stud Nuts	ASTM A194 2H Carbon Steel
23	Base Stud Nuts	ASTM A194 2H Carbon Steel	46	Main Bonnet Plug	ASTM A182 F304 SSt.
24	Eye Bolt Lock Nut	Carbon Steel	47	Main Base Nameplate ⁶	Stainless Steel
25	Pilot Bonnet Gasket	Soft Iron	48	Pilot Base Nameplate ⁶	Stainless Steel
26	Eye Bolt	Carbon Steel	49	Main base Drain Plug	ASTM A182 F304 SSt.
27	Adjusting Ring Pin	ASTM A582 416 ¹	50	Main Base Nameplate Screws ⁶	Steel (Nickel Plated)
28	Adjusting Ring	ASTM A743 CA15 SSt.	51	Pilot Base Nameplate Screws ⁶	Steel (Nickel Plated)
29	Pilot Bonnet Assembly		52	Sensing Tube Flange Gasket	ASTM A167 304 SSt. ⁴
29a	Bonnet	ASME SA216 WCC CS	53	Adjusting Ring Pin Gasket	Soft Iron
29b	Guide	ASTM A479 316L SSt.	54	Seal ⁶	Aluminum
29c	Pin	ASTM A479 304 SSt.	55	Seal Wire ⁶	Steel
30	Bottom Spring Washer	Carbon Steel (Zinc Plated)	56	Disc Spring (Main Valve)	Inconel X-750
			57	Disc Spring Ring	ASTM A479 410 ¹

Notes:

1. Cond. A Stainless Steel
2. Elgiloy Spring
3. Cond. T Stainless Steel
4. Nobestos Filled
5. Malleable Iron
6. Not Shown

Materials (Contd.)

13900 Type Pilot Valve

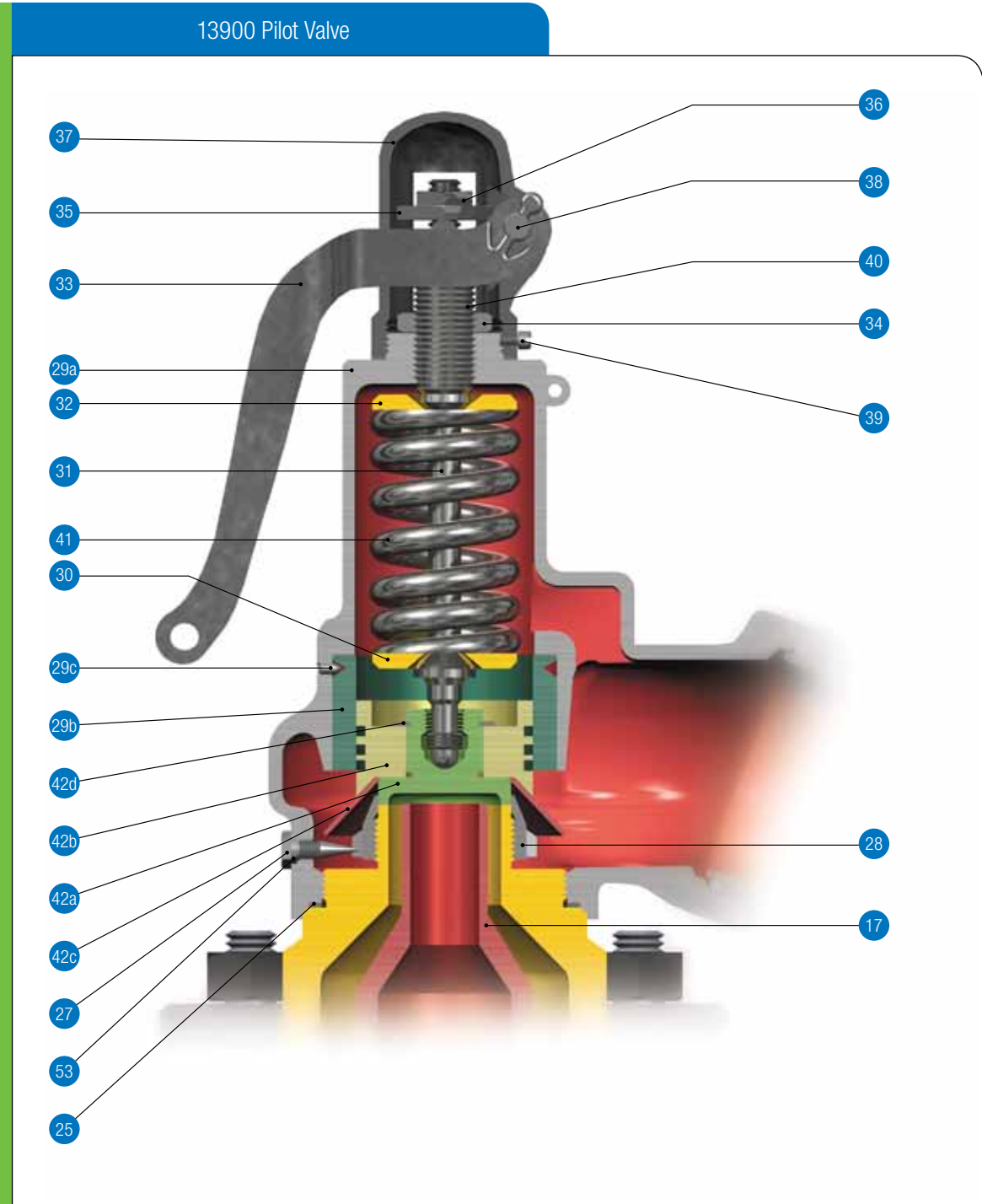

Options

Standard Options

The Consolidated® 13900 Series Valves are available with the following options:

Omit Pilot Discharge Piping:

Pilot Valve Vent to area other than main valve outlet.



Dump Valve Design:

Rather than having a spring loaded safety valve as its pilot valve, which opens automatically at the pre-determined set pressure, the dump valve has a pilot which is operated by an electrical signal so that the valve may be opened at any time independently of the steam pressure.



Dimensions & Weights

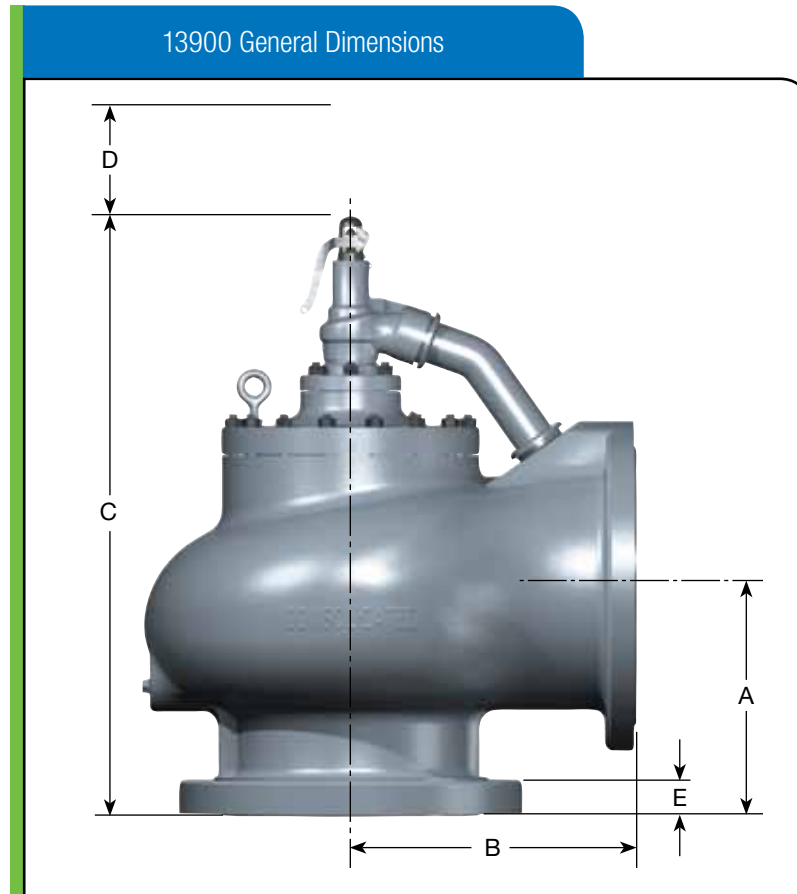

13900 Valve General Dimensions & Weights

Valve Type	A		B		C		Dismantling Height D		E		Approx. Weight	
	in.	mm	in.	mm	in.	mm	in.	mm	in.	mm	lb.	kg
13906-114	17.00	431.8	21.00	533.4	48.00	1219.2	55.00	1397.0	2.50	63.5	1900	861.8
13906-143	18.00	457.2	22.00	558.8	49.50	1257.3	56.00	1422.4	2.38	60.3	2500	1134.0
13906-176	20.00	508.0	25.00	635.0	54.00	1371.6	60.50	1536.7	2.50	63.5	3650	1655.6
13906-200	20.00	508.0	25.00	635.0	54.00	1371.6	60.50	1536.7	2.50	63.5	3650	1655.6

Capacities

Valve Capacity for ASME B&PV Code Section VIII - Standard Bore, Steam

Based at 10% overpressure or 3 psig (0.21 barg), whichever is greater, showing 90% of actual capacity.

Orifice Designation		114		143		176		200	
Orifice Area		in ²	cm ²	in ²	cm ²	in ²	cm ²	in ²	cm ²
		114.000	735.480	143.100	923.224	176.700	1140.000	201.000	1296.770
Set Pressure		Orifice Capacity							
psig	barg	lb/hr	kg/hr	lb/hr	kg/hr	lb/hr	kg/hr	lb/hr	kg/hr
50	3.44	358876	162783	450483	204335	556257	252313	565655	256576
60	4.13	415513	188473	521578	236583	644046	292134	654926	297069
70	4.82	472151	214164	592673	268831	731834	331954	744198	337562
80	5.51	528788	239854	663768	301080	819622	371774	833469	378055
90	6.20	585426	265544	734863	333328	907410	411594	922740	418547
100	6.89	642063	291234	805958	365576	995198	451414	1012012	459040
120	8.27	755338	342615	948148	430072	1170775	531054	1190554	540026
140	9.65	868613	393996	1090338	494569	1346351	610694	1369097	621011
160	11.03	981888	445376	1232529	559065	1521927	690334	1547640	701997
180	12.41	1095164	496758	1374719	623562	1697504	769974	1726183	782983
200	13.78	1208439	548138	1516909	688058	1873080	849614	1904725	863968
220	15.16	1321714	599519	1659099	752554	2048656	929254	2083268	944954
240	16.54	1434989	650900	1801289	817051	2224233	1008895	2261811	1025940
260	17.92	1548264	702280	1943479	881547	2399809	1088535	2440353	1106925
280	19.30	1661539	753661	2085669	946043	2575386	1168175	2618896	1187911
300	20.68	1774814	805042	2227859	1010539	2750962	1247815	2797439	1268897

Valve Capacity for ASME B&PV Code Section VIII - Standard Bore, Air

Based at 10% overpressure or 3 psig (0.21 barg), whichever is greater, showing 90% of actual capacity.

Orifice Designation		114		143		176		200	
Orifice Area		in ²	cm ²	in ²	cm ²	in ²	cm ²	in ²	cm ²
		114.000	735.480	143.100	923.224	176.700	1140.000	201.000	1296.770
Set Pressure		Orifice Capacity							
psig	barg	ft ³ /min	m ³ /min	ft ³ /min	m ³ /min	ft ³ /min	m ³ /min	ft ³ /min	m ³ /min
50	3.44	127904	3621	160553	4546	198251	5613	201600	5708
60	4.13	148089	4193	185891	5263	229539	6499	233417	6609
70	4.82	168275	4765	211230	5981	260827	7385	265233	7510
80	5.51	188461	5336	236568	6698	292115	8271	297050	8411
90	6.20	208647	5908	261906	7416	323402	9157	328866	9312
100	6.89	228832	6479	287245	8133	354690	10043	360683	10213
120	8.27	269204	7623	337922	9568	417266	11815	424316	12015
140	9.65	309575	8766	388598	11003	479842	13587	487949	13817
160	11.03	349947	9909	439275	12438	542418	15359	551582	15619
180	12.41	390318	11052	489952	13873	604993	17131	615214	17420
200	13.78	430690	12195	540629	15308	667569	18903	678847	19222
220	15.16	471061	13338	591306	16743	730145	20675	742480	21024
240	16.54	511432	14482	641982	18178	792721	22447	806113	22826
260	17.92	551804	15625	692659	19613	855296	24219	869746	24628
280	19.30	592175	16768	743336	21048	917872	25991	933379	26430
300	20.68	632547	17911	794013	22483	980448	27763	997012	28232

Valve Configuration Code

13900 POSRV Valve Coding

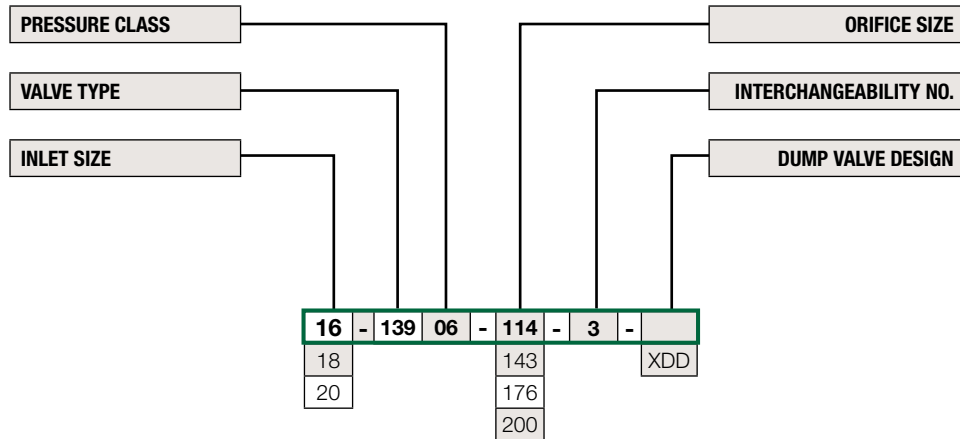

Standard Valve Construction

Designation	Inlet Size		Orifice Size	
	in.	mm	in ² .	cm ²
114	16.0	406.40	114.000	735.482
143	18.0	457.20	143.100	923.224
176	20.0	508.00	176.700	1139.998
200	20.0	508.00	201.000	1296.772

Pressure Class

Designation	Class
06	300#

How to Order a 13900 POSRV

13900 POSRV Specification Sheet

	Page ____ of ____
Requisition No.	_____
Job No.	_____
Date	_____
Revised By	_____

General

1.	Number of Valves:
2.	Size of Valve Inlet:
3.	Type Number of Valve:
4.	Consolidated® Manufacturer:
5.	Body Material:
6.	Trim material (if any other than standard is required):
7.	O-Ring Seat Material:
8.	Set Pressure:
9.	Opening temperature and Relieving Temperature:
10.	Back Pressure, if any (indicate if Constant or Variable):
11.	Required Capacity:
12.	Lading Fluid:
13.	Allowable Overpressure:
14.	Density:
	a. Vapor - Molecular Weight:
	b. Gases - Specific Gravity (Air = 1):

Other

15.	Code Marking Required
	a. ASME Unified Pressure Vessel Code:

Notes

